

# PERSONAL COMPUTER WORLD

50p U.S.\$2.00

**BEGINNER'S  
GAMBIT**

**SMALL SYSTEMS  
ARE GOOD FOR  
SMALL  
BUSINESSES**

JULY 1979

Europe's first magazine for personal computers for home and business use

**The Programmed Punter**  
**Visionlink**  
**The Soft Cursor**  
**Getting In The Swim**



**Valerie Downes: Using the Sorcerer**

# If you buy the wrong personal computer, you can't re-program your bank account!

Buying a personal computer is not an easy task.

So many people selling them neglect the little things that enable you to get the most from your computer, such as documentation, spares, add-ons and maintenance. We believe that these 'details' are essential. We are the only British company to put all our time and energy into the personal computer market and are in the best position to advise you on your initial purchase and keep you fully informed about all the new developments relevant to your computer.

Personal Computers Limited — *the name of the game.*

Say 'hello' to a graphics **Apple II**



A business **Apple II**



Exclusive to Personal Computers Ltd.  
German **Apple II**. Available shortly.



# Personal Computers Limited

194-200 Bishopsgate, London EC2M 4NR.  
Tel. 01-283 3391

**Apple Software Bank**  
Free membership to all Apple owners  
POST TO: Personal Computers Ltd., 194-200 Bishopsgate,  
London EC2M 4NR.  
NAME .....  
ADDRESS .....

Unleash your Pet\* to its full capability.



## Two ways to 32K. Add on or add in.

### One way: Petite memory system.

- Self-contained peripheral for any Commodore Pet.
- Plugs into mains and Pet.
- No modifications required.
- No demands on Pet power supply.
- No extra heat dissipation within Pet cabinet.
- No warranty problems.

### The Other: Inpet memory board.

- Mounts onto Pet processor board.
- Built in PSU.
- Simple to fit.
- Complete with all connectors.
- Low cost version.

\* Trademark of Commodore Business Systems.

One way or the other you get a reliable memory from Plessey Microsystems, Europe's leading memory manufacturer. Either way you get a memory to make your Pet more like a powerful business computer.

Available from authorised distributors of Plessey Pet peripherals. Send for full information and the address of your nearest distributor.

 **PLESSEY  
MICROSYSTEMS**

Plessey Microsystems Limited, Water Lane, Towcester, Northants NN12 7JN Telephone: Towcester (0327) 50312 Telex: 31628

 0654-2-0099

# Payroll, Pete and Friends Professional **PET** Software *At last*

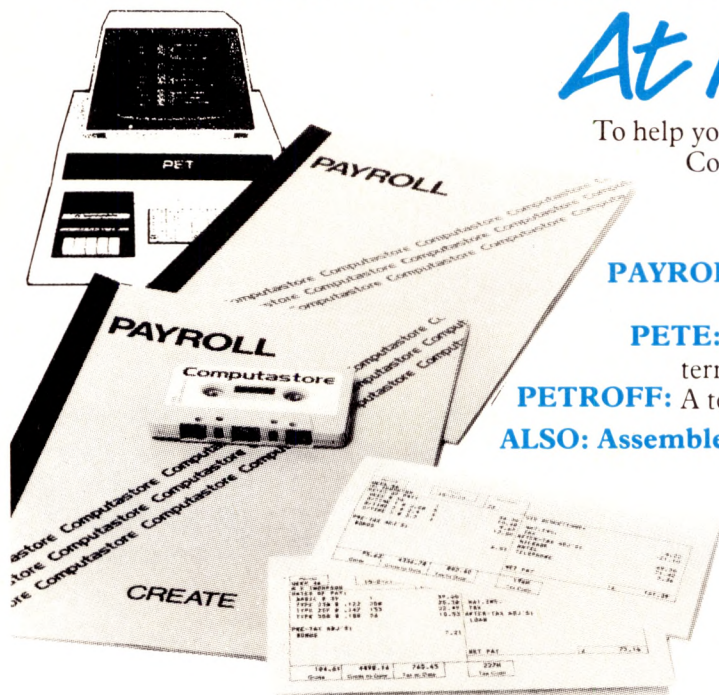

To help you get the most out of your Commodore PET, Computastore has developed a range of software packages to cope with the demands of both Industry and Education.

**PAYROLL:** Runs on the 8K PET and produces pre-printed payslips, totals and coin analysis.

**PETE:** Turns your PET into an intelligent RS-232 terminal for use with a mainframe.

**PETROFF:** A text formatter to produce neatly typed reports.

**ALSO: Assembler, Disassembler, Renumber, Keyboard.**

Contact your PET dealer or Computastore for a demonstration.

## Computastore

Software that means business

Computastore Ltd, 16 John Dalton Street,  
Manchester M2 6HG. Tel: 061 832 4761

## New Low-cost Printer from **PHL**

### Anadex DP 8000

- 80 Columns
- 112 cps - 84 lpm bi-directional
- 1K Print Buffer
- Dual Interface - Serial & Parallel
- 96 ASCII set, 9 x 7 matrix

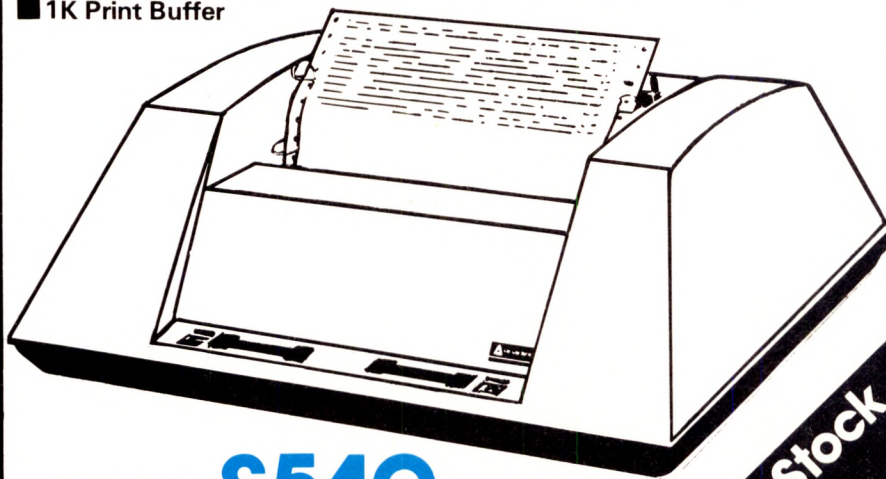

From Only **£540**

**Ex Stock**

#### Also available Visual Displays

- |                   |                 |
|-------------------|-----------------|
| Lear Siegler      |                 |
| ADM - 3A          | from only £ 571 |
| ADM - 3A Graphics | from only £1395 |
| ADM - 31          | from only £ 809 |
| ADM - 42          | from only £1149 |

#### Keyboard Printers

- |                     |                 |
|---------------------|-----------------|
| Teletype 43         |                 |
| Pin Feed            | from only £ 799 |
| Friction Feed       | from only £ 818 |
| Typewriter Terminal | from only £ 825 |
| Portable Models     | from only £ 899 |
| Digital             |                 |
| LA 36               | from only £ 849 |
| LA 34               | from only £ 911 |
| LS 120              | from only £1679 |

#### Printers

- |                    |                 |
|--------------------|-----------------|
| Texas 810          | from only £1392 |
| SCI Rotary Printer | from only £ 747 |

#### Data Storage

- |                     |                 |
|---------------------|-----------------|
| Techtran            |                 |
| 950 Microdisc Range | from only £ 955 |
| 815 Daticassettes   | from only £ 667 |

#### Other Items

- |                         |                 |
|-------------------------|-----------------|
| AJ 211 Acoustic Coupler | from only £ 199 |
|-------------------------|-----------------|



PERIPHERAL HARDWARE LIMITED  
Armfield Close, West Molesey  
Surrey England Telex 922175  
Sole UK distributor

South 01-941 4806 North Wetherby 61885 Ireland Dublin 971854

# SORCERER™



## A real business computer designed by business people

\* 1,920 CHARACTER DISPLAY

\* WORKS WITH NORMAL TV

\* PLUG IN PROGRAMME CARTRIDGES

\* OUTPUTS TO PRINTER

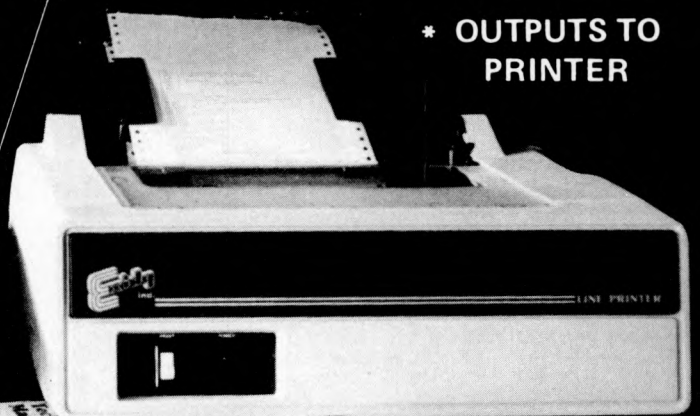
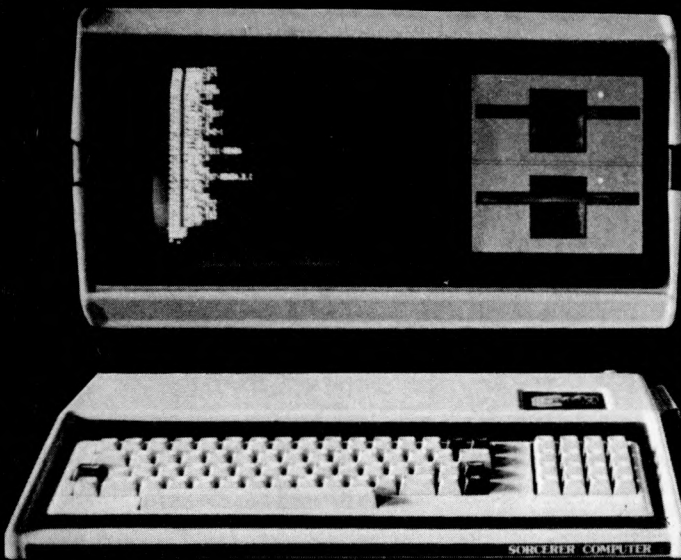

\* EXPANDS TO 48 K

\* WORD PROCESSING

\* MANY EXPANSION FACILITIES

The Sorcerer Computer is a completely assembled and tested computer system ready to plug in and use. The standard configuration includes 63 key typewriter style keyboard and 16 key numeric pad, dual cassette I/O, with remote computer control at 300 and 1200 baud data rates, RS232 serial I/O for communication, parallel port for direct Centronics printer attachment, Z80 processor, 4K ROM operating

system, 8K Microsoft BASIC in separate plug-in Rom Pac™ cartridge, composite video of 64 chars. 30 lines, 128 upper/lower case ASCII character set and a 128 user-defined graphic symbols, up to 32K on board RAM memory, operators manual, BASIC programming manual and cassette/video cables, connection for \$100 bus expansion unit giving access to the spectrum of exciting and useful

peripheral devices, such as Floppy disk drives, voice recognition/synthesis battery back up board in case of power failure, additional memory boards, EPROM cards give you the facility to program and re-program your own ROM memories etc. etc. This is the most useable and flexible system that's now available to the home and business user at such a low price.

NOW CONTACT YOUR LOCAL DEALER

OR SEND COUPON FOR FURTHER INFORMATION

PRICES	£
8K Sorcerer	650
16K Sorcerer	760
32K Sorcerer	859
630K Dual Disc Drive	1,200
143K Single Disc Drive	500
\$100 Expansion Unit	210
Line Printer	850.00
Video Display	240.00
Development Pack	70.00
Word Processing Pack	70.00
Technical Manual	8.95
Memory Expansion 16K	110.00

Factor One Computers Ltd.  
11 17 Market Place,  
Penzance.  
Tel: (0736) 66336 or 66565

- LANCASHIRE**  
051 236 0707 MICRODIGITAL 25 Brunswick St., Liverpool L2 8J
- WEST YORKSHIRE**  
053 65094 BASK COMPUTING Oakville, Oakworth Rd., Keighly
- SHEFFIELD**  
0742 668767 E.S. MICROCOMPUTERS 7 Berkley Precinct, Ecclesall Rd., S11 8PN
- NORTH WALES**  
0248 52042 TRYFAN A V SERVICES 3 Swifts Bldgs., High St., Bangor, Gwynedd
- AVON**  
0272 292375 ELECTROPRINT 5 Kingsdown Parade, Bristol BS6 5UD
- NORTH HANTS**  
0536 83922 H.B. COMPUTERS LTD. 22 Newland St., Kettering
- LONDON & Counties**  
**BERKSHIRE**  
0635-30505 NEWBEAR COMPUTING STORE 40 Bartholomew St., Newbury RG14 5L L
- KENT**  
01-300 0380 INFORMEX 61 Harland Avenue, Sidcup, DA15 7NY
- SURREY**  
0276 34044 MICROBITS 34b London Rd., Blackwater, Camberley
- 0276-62506 T. & V.J. MICROCOMPUTERS 165 London Rd., Camberley

Geoff Wilkinson, **FACTOR ONE Computers Ltd.** 11-17 Market Place, Penzance.  
Please send me details of the SORCERER COMPUTER  
Name \_\_\_\_\_  
Address \_\_\_\_\_  
Tel. No. \_\_\_\_\_  
Tel: (0736) 66336 or 66565

# PERSONAL COMPUTER WORLD

Europe's first magazine for personal computers for home and business use

UK 50p  
US \$ 2.00

Vol. 2 No. 3  
July 1979

## CONTENTS

ISSN: 0142 0232

<b>EDITORIAL</b> . . . . .	7	<b>GETTING IN THE SWIM</b> <i>David Goadby</i> An eclectic solution to obtaining a machine-independent monitor for 6800 systems . . . . .	51
<b>PUBLISHER'S LETTER</b> . . . . .	7	<b>PCW OPEN PAGE</b> <i>Mike Lord</i> Our POP SHOP service is booming . . . . .	53
<b>LETTERS</b> . . . . .	9	<b>PCW BOOK REVIEW</b> <i>Michael James</i> . . . . .	55
<b>TIDBITS</b> . . . . .	13	<b>BEGINNER'S GAMBIT</b> <i>R.A. Diamond</i> Chess programming too difficult for you? Begin here . . . . .	57
<b>IN WHICH LANGUAGE SHOULD I PROGRAM MY MICROCOMPUTER?</b> <i>Martin Beer</i> Basic or Pascal? . . . . .	20	<b>PET PREENING</b> <i>Rupert Steele</i> It's a SNAP . . . . .	59
<b>OWNER'S REPORT</b> <i>Valerie A Downes</i> The Sorcerer Hexperience . . . . .	23	<b>THE SOFT CURSOR</b> <i>M.O. Benjamin</i> Extended Cursor Graphics for the TRS-80 . . . . .	60
<b>SMALL SYSTEMS ARE GOOD FOR SMALL BUSINESSES</b> <i>John Braga</i> The Director of Computerland puts forward an informative case for the small system in business . . . . .	29	<b>APPLEDEM</b> <i>G.F. Filbey</i> Concluding the Applevision article . . . . .	65
<b>ON THE LINE</b> <i>David Hebditch</i> The latest in a series of articles exclusive to PCW. This one is on Communications Input/Output . . . . .	31	<b>ERROR MESSAGES</b> . . . . .	67
<b>D to A CONVERTER</b> <i>John Coll</i> John Coll is a computerist's computerist . . . . .	35	<b>THE PROGRAMMED PUNTER</b> <i>Dr. M.R.J. Morgan</i> Have fun — learn about probability . . . . .	70
<b>PRACTISING A LITTLE MICRO-CONTROL</b> <i>Mike Dennis</i> A signal contribution to understanding control signals . . . . .	37	<b>PARKINSON'S REVAS</b> <i>D.W. Parkinson</i> Continuation of the Reverse Assembler listing . . . . .	74
<b>VISIONLINK</b> <i>W.G. Marshall</i> Interfacing and software for the Author's Superscamp VDU . . . . .	42	<b>ADVERTISERS' INDEX</b> . . . . .	52
<b>HELLO Z8000</b> <i>Mike Lord</i> Greetings to a muscular microprocessor . . . . .	47	<b>Buzzwords</b> by Peter Reynolds, and <b>Statpack</b> by Colin Chatfield, will appear in the next issue.	

### Editorial and Advertising Office:

62A Westbourne Grove, London W2

Phone: 01-229 5599 (Publisher)

01-727 8758 (Editorial)

01-229 5589 (Advertising & Subscriptions)

### Publisher:

A Zgorelec

### Editor:

Meyer N. Solomon

### Editorial Assistant:

David Bannister

### Policy Adviser:

Peter Crofton-Sleigh, FRAS

### Consultants

John Coll, Mike Dennis, Neil Harrison, Charles Sweeten, Patrick Sutton, Michael James, R. W. Davy, David Hebditch, Sheridan Williams, Stephen Castell, Dr. D.J. Hand.

Art: Sauveur Laurent Sant, Kathryn Hamme

### Secretarial:

Vanessa Blackburn Kiddle

### Layout Consultant:

David G. McFarlane

PCW Photography: Yoshi Imamura, Peter McGee

Typesetting & Artwork: Gilfillan

Cover Photo: Kaveh Khan

### CONTRIBUTORS:

We welcome interesting articles written simply and clearly. You need not be a specialist to write for us. MS should not be more than 3000 words long, lines double spaced, with wide margins. Line drawings and photographs wherever possible. Enclose a stamped self-addressed envelope if you would like your article returned.

Manufacturers, suppliers and dealers are welcome to contribute technical articles, and send product information, but we are pledged to an independent viewpoint and will publish evaluations and reasoned criticism or praise, space permitting. Naturally there will be right of reply. Views expressed in articles are not necessarily those of Personal Computer World.

We may make arrangements to offer our readers products at special prices, for a limited period, in line with the policy outlined above.

Published monthly by Intra Press, 62A Westbourne Grove, London W2. Phone 01-229 5599. Contents fully protected by copyright. All rights reserved. Subscription rates: Britain £8 for 12 issues. Prices include postage. USA — \$10 for six issues, \$20 for 12 issues. Continent and elsewhere £9.80 for twelve issues. Prices include postage.

Printed by Keats Printing Limited, 12 Fouberts Place, London W1V 1HH. Sole UK Distributors Seymour Press Ltd., 334 Brixton Road, London S.W.9., England. Distribution to specialist shops by Intra Press.

## Editorial

### On Correcting the Menu

I had occasion once to go to a fairly "classy" restaurant. During the course of the meal a diner at the next table began cutting up a waiter with the sharp edge of his tongue. While this went on, I took shelter behind my knife and fork and (not inaptly) ruminated over the incident, thinking how much better it would have been if the customer had complained to the man who should have borne the responsibility for whatever strange animal he'd found in his food — the manager of the restaurant.

This leads me to say that, in general, authors are not to blame for errors found in PCW. Ultimately, responsibility lies with the editor.

## Publisher's Letter

The NCC Show in New York, held last June, was a colossal affair. The editor went over by DC10, seated where he could watch the wing as if his life depended on it. The results of his visit will appear in the next issue of our sister publication, **Computer Trader**.

I would like to thank all our consultants for helping to make PCW the best magazine of its kind in Europe. In particular, it is no exaggeration to say that we would not have got off the ground had it not been for **John Coll**, **Charles Sweeten**, **Neil Harrison** and **Mike Dennis**, who were with PCW from its beginning.

### SUBSCRIPTIONS

When PCW started publication, we had a special six-issue offer. When these subscriptions expired, we sent out reminders.

*The renewal rate was 70%!*

PCW reader loyalty is becoming a byword in publishing. If you're having difficulty in obtaining PCW at your newsagent, take our subscription. You can find the details at the foot of P.5.

STOP PRESS! £1,500 CASH — FIRST PRIZE

### Second PCW Microprocessor Chess Tournament

Following the success of the first PCW Chess Tournament last year, we are pleased to announce that our second tournament will take place at the PCW show in London, November 2nd - 4th 1979.

It is hoped that some financial support may be available for private entrants from outside the U.K., to defray travelling expenses, and there will be at least one cash prize. The highest placed programs will be eligible to compete in the first

**World Microprocessor Championships** which will be held at the 1980 PCW Show.

Detailed rules and entry forms will be available in due course.

Prospective entrants are requested to write to

David Levy (c/o Personal Computer World, 62a, Westbourne Grove, London W2) who will be acting as commentator and tournament manager.

SPONSORSHIP INVITED FOR 2nd & 3rd PRIZES

PCW Vol 1  
KCAR  
SREBNUM

Sold Out — No. 9  
Sold Out — No. 7  
Sold Out — No. 5  
Sold Out — No. 4  
Just a few left of — Nos. 3, 6.

If you think No. 10 will be available in 2 months' time — don't count on it. Nos. 1, 2, and 8 are still in good supply.

Think of the future — Look Backwards!

### NORTH STAR HARDWARE

	Ass.	Kit
HORIZON-0-0K	£ 650.00	£ 475.00
HORIZON-1-32K-0	£1445.00	£1125.00
HORIZON-2-16K-0	£1575.00	£1245.00
HORIZON-2-32K-0	£1755.00	£1375.00
Z80A Processor board	£ 175.00	£ 145.00
Hardware floating point board	£ 215.00	£ 195.00
16K Dynamic RAM board (200ns access time)	£ 275.00	£ 225.00
32K Dynamic RAM board (200ns access time)	£ 425.00	£ 375.00
HRZ SIO Serial port	£ 45.00	£ 29.00
HRZ PIO Parallel port	£ 45.00	£ 29.00
North Star compatible diskettes box of 10	£ 25.00	n/a
<b>OTHER MANUFACTURERS</b>		
Cromemco TU-ART I/O card	£ 180.00	£ 130.00
Heuristics model 20S Speech recognition card	£ 145.00	n/a
Heuristics model 50 Speech recognition card	£ 225.00	n/a
George Morrow 8080A CPU/Front panel	£ 195.00	£ 175.00
George Morrow "Switchboard"	£ 150.00	£ 120.00
Elbits DS1920 Model 30 VDU	£ 700.00	n/a
Intertec Intertube II VDU	£ 525.00	n/a
DEC Writer LA36	£ 915.00	n/a
DEC Writer LA34	£ 915.00	n/a
Amp S-100 Bus compatible edge connectors	n/a	£ 3.00

All the above prices are exclusive of VAT and carriage, and are correct at time of going to press. Attractive OEM and Educational discounts available. Please send large S.A.E. for details.

INTERAM Computer Systems Ltd.  
59 Moreton St. Victoria, London SW1

INTERAM

## Losers - Weepers

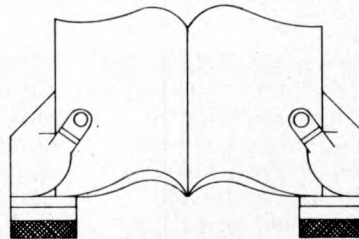

## BINDERS - KEEPERS

Half the worried people you meet today are not preoccupied with pollution, perversion or persecution. It's worse than that — they've lost a copy or two of PCW and don't know where to find replacements.

So keep *your* copies of PCW in a beautiful bright blue binder.  
£2.95 worth of smart security.

Binders are now available.  
Orders already received get priority.

Payment by cheque or postal order  
£2.95 (includes p+p) made out to  
Intra Press. Please allow 28 days for delivery.  
"Binders", PCW, 62A Westbourne Grove,  
London W2.

# comart

## ...the specialists

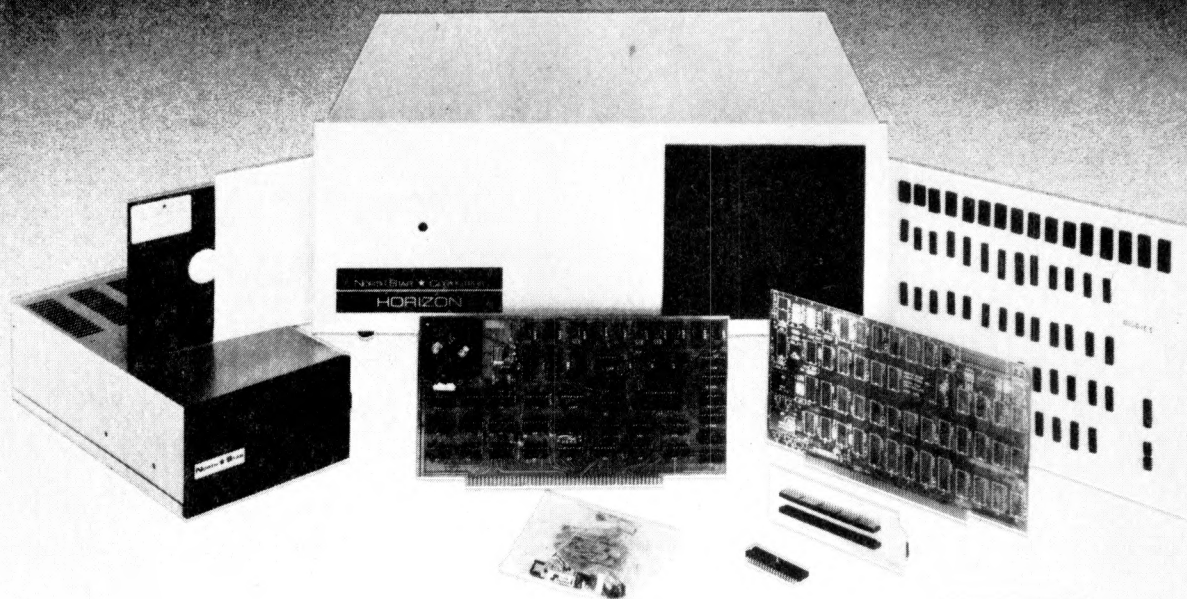

The complete range of North Star computer products in both kit and assembled form is offered by Comart: The Horizon computer, the Microdisk System, memory and floating point arithmetic board. And, Comart being S100 specialists, other items from our computer catalogue may be easily added to meet your requirements.

Teaching, Research, Engineering and Commerce .... each field has applications where this state-of-the-art technology provides cost effective processing of immediate benefit.

Comart quality. Each assembled module is final-tested by our own engineers. Take delivery of a computer system – plug in a wide variety of peripherals and use it.

Attractive prices, good delivery and a choice of Comart's factory repair or on-site service with a Computer Field Maintenance contract make the acquisition of a Comart computer a safe decision.

Find out more – ask us for the Comart catalogue of Computers.

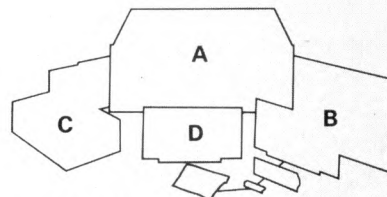

The North Star dual drive double-density Horizon computer **A** together with a typical kit product **B**, the Microdisk system drive **C** and hardware floating point board **D**.

Contact us direct or call your nearest Comart dealer

**The Byte Shop**, Ilford, Essex. Tel: 01-554 2177  
**Cambridge Computer Store**, Cambridge. Tel: (0223) 68155  
**Microcomputermart Ltd.**, Manchester. Tel: 061-832 2269  
**Crayworth Ltd.**, Camberley, Surrey. Tel: (0776) 34044  
**Digitus Ltd.**, London W.1. Tel: 01-636 0105  
**Holdene Ltd.**, Leeds. Tel: (0532) 459459  
**Isher-Woods Ltd.**, Luton, Beds. Tel: (0582) 424851  
**Newbear Computing Store**, Newbury, Berks. (0635) 30505  
**Xitan Systems Ltd.**, Southampton. Tel: (0703) 38740



### comart specialists in microcomputers

Comart Ltd., P.O. Box 2, St. Neots, Huntingdon, Cambs, PE19 2AF. Tel: (0480) 215005 Telex: 32514



# Letters

## Lost in the bewilderment

I was very interested reading the article published in your April issue by Mr. D.R. Worsley, for he has touched many points which I and some of my business colleagues feel are most vulnerable. It is however our intention to try and remedy this by filling in the gaps, but alas we had no success. Our knowledge is very limited (virtually zero), and yet our enthusiasm is great, and we aim at buying our small computer (micro) to be able to carry out all our tasks of accountancy, i.e. sales ledger and analysis, order entry, invoicing, stock control and recording, payroll, VAT. The problem is and remains our limited knowledge in the size of memory, storage, and type of system (i.e. diskette or cassette) which would be most suited to our needs.

We had thought that a dual floppy disk would be most advantageous for its speed in retrieving information, the storage and also market availability, but which one? It is difficult to say which between: TRS-80 Level II, Pet, Apple II, Exidy Sorcerer, Horizon, Cromemco System II, Challenger C24P, etc. etc. There are so many! There is also another point to consider, that is the money available for the purchase of the micro-computer is limited, at the moment to £2000 – £2500, and this, I know, will limit our potential as buyers. But we would like to look for something which will be possible to expand, when more money is available to us. And also we would like to choose the one where the manufacturer offers good software and hardware backing.

We would like some sound advice on how to go about it all, what to look for what to read and also some advice in developing our own software system (any books on analysis and design of a system for microcomputers).

Eagerly waiting for all the advice you could send us.

## G. Santini and Friends

61 Victoria Road, Cambridge CB4 3BW.

PCW An interesting and beautifully written reply to Mr. Worsley's article, written by Mr. Braga of the Byte Shop, Nottingham, is published in this issue. Consultant Sheridan Williams will also go some way toward helping Mr. Santini and friends in a reply to another reader's query. The Nottingham Shop is now known as Computerland.

## Dual Access

I wonder if some manufacturer would entertain the idea of making available a memory block which is dual accessible as illustrated in the accompanying diagram.

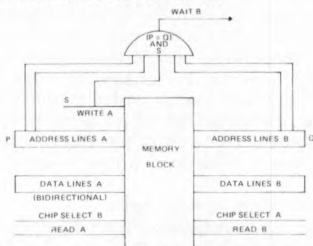

This is certainly less interfering in the amount of time taken in holding up one system by another compared with DMA or memory mapping.

Dr. S.R. Silvapulle

1 Dale Avenue, Edgware, Middlesex.

## SUNBURNT PROMS

I have a free 2708 PROM waiting for the first reader who can tell me how to cure a sunburnt PROM – and advice for readers who intend to build their own PROM laundry.

The advice: incorporate an exposure timer! I didn't and as a result I now have 6 sunburnt PROMs. You may think, as I did, that you couldn't forget to switch off after the ten minutes required to clean out a PROM. But you can fall asleep – at least I did, and as a result my PROMs got a 2 hour dose of hard U.V.

The result was that in all 1204 locations bit 1 is stuck low. All the other 7 bits program and clear O.K., but no amount of cycling has revived bit 1.

Apart from this problem, my laundry works very well, so here are a few notes for those readers contemplating building their own.

You won't find suitable U.V. tubes in stock at your local electrical shop. If they stock any kind of U.V. tube at all it will be the black tube type, which is useless for PROM cleaning because the U.V. wavelength is too long. The correct U.V. tubes, which emit "hard" – i.e. short wave U.V. are made from a special glass which is transparent to both U.V. and visible light. These are stocked by hairdresser suppliers, in the 18in 15 W size. However, they won't stock the control gear (unless you want a sterilizer instead of a PROM laundry). Back at your local electrical shop you will find that control gear for a 15 W tube is just not made! This is because the choke is the same as that made for

a 3 ft. 30 W tube. You might think that this choke would overload your lamp, but this doesn't happen – the 30 W choke will run your lamp at 15 W, and, indeed, this is the lamp manufacturer's recommendation.

Use a starter switch with a translucent cover, and don't hide it inside your case. It then acts as a pilot and glows when the lamp is switched on but is not working.

Make sure your case is U.V. proof. Remember, it takes a week's exposure to the sun to erase a PROM, but only 10 mins. in the laundry – i.e. the lamp is 1000 times stronger in U.V. than the sun. Don't get sunburnt!

Grahame Coates,

4 Ventris Close, Hadleigh Road, Ipswich IP2 0DB.

## Redrawpic

I enjoyed reading the program 'Drawpic' in your Feb '79 issue. However I found my Level II 4K TRS-80 scarcely big enough to hold it: indeed when I entered the program with some redundant spaces to increase legibility, I ran out of memory.

I therefore recommend anyone using the program to insert between lines 3 & 4 the line

```
DEFINT B – Z
```

and renumber accordingly.

Since integers are stored in 2 bytes as against 4 bytes for reals, this will approximately halve the space required for data.

If you go further and make the line read

```
DEFINT B – Z : DEFSTR A
```

then you can omit the \$ after every A, saving 19 characters. Since DEFSTR is stored as one byte in the Level II TRS-80 this saves space as well as wear on the fingers.

If you want to save even more space, since both x and y lie in the range 0 – 127, you can pack the x and y co-ordinates into one integer; e.g.

$w(n) = 256 * x + y$  and unpack e.g.

set  $(w(n)/256, w(n) - 256 * (w(n)/256))$

Thus we require only 2 arrays instead of 4, halving the space requirement again.

J.S. Linfoot

Flat 10, Pembroke Court, Rectory Road, Oxford OX4 1BY.

## The Pet IPUG

In the article 'In Defense of PET' a number of items require further comment.

1. With the new improved PETs comes a new improved PET User's handbook.

2. The IEEE-488 standard has the equivalent IEC TC-66. This basically differs only in the connector standards, which PET does not use anyway.

3. The keytop wear problem on the earlier PETs has been solved and no longer occurs. Replacement keytops are available from Commodore.

4. The Newsletter of the Independent PET Users Group is another useful source of information.

R.D. Geere, Editor, IPUG Newsletter.

52 Highfield Road, Cove, Farnborough, Hants, GU14 0EB.

## Creative translation

I feel that I should clarify some points that have arisen from the correspondence on my previous letter. (PCW, March '79).

The reason I transcribed the algorithm for programmable calculators was to show how one should not automatically assume that a program written for a computer is impossible to run on a programmable calculator. The second point of my letter was, once the program works it should not be abandoned if the running time is too long; hence my modification of including the Newton-Raphson formula.

As a result of this, the initial algorithm provides an excellent starting point for N.R. when the two programs are combined. The principle of N.R. is that a starting value, which is near to the root of the equation, is modified to a more accurate answer. Any shorter program must use guess work in calculating the first value – such as taking some fraction of the initial number.

To summarise then, I did not try to create a solution to a problem, but to show how to use other solutions in a creative way.

I.W. Morrison

54 The Fairways, Leamington Spa, Warwickshire. CV32 6PS.

## TRS-80 Line Renumbering Program

I found it strange that the renumbering routine listed in the May issue should give an error message when confronted with the problem of fitting a two digit line number in the space formerly occupied by a one digit number, in fact of replacing any line number by a larger one.

I have already written a program which creates spaces in the TRS-80's BASIC text. All that is necessary is to move the required block of text up as far as is desired, using the Z80's LDDR function, then to update the two bytes at the beginning of each line which indicate the start of the next line and finally

to adjust the two bytes 16633 and 16634 (40F9 and 40FA Hex) which together should always contain the address of the byte just after the BASIC program text's end.

**Michael Burrows (Age 16)**  
 42 Hawthorn Avenue, Palmers Green, London N13 4JT.

**Safety first**

With reference to Mr. P.F.T. Tilsley's letter in *PCW* (May issue) on the subject of a simple solution to restricted I.F. bandwidth of a broadcast T/V. R/X.

Readers should note that it is not recommended (if you value your computer) to feed video from a UART straight to the video O/P stage of a live chassis TV. The only correct way, of course, is to fit a mains I/P isolation T/X; which is expensive, and fairly heavy! The point is that a R.F. I/P is subject to I/F noise (snow) rather than restricted I/F bandwidth; as an average TV should resolve 5.5MHz; therefore a good quality modulator should be used. Play safe, use isolated A/E skt. and don't give your first love a chance to say, "I told you that damn computer was a waste of money", as you throw it in the scrap bin.

**R. Keller**  
 "Paddock End" Polperro Drive, Freckleton, Preston, Lancs.

**Miskeying the Miskeys**

This morning's post brought my copy of *PCW* and a pleasant surprise: the publication of my letter (in *PCW*, May) with regard to miskeying.

However, after reading the published version of my letter, I was not so pleased. Owing to certain errors and one omission, the letter now reads like a garbled output from some delinquent computer. I realise the information I intended to impart was hardly earth-shattering, but at least someone, I would have thought, would have noticed the illogicality: 'The normal interrupt key is the division (+) key', although to be fair, on this typeface the division sign does look like the plus sign.

Could I therefore prevail upon you to perhaps publish a correction for lines 18 ('For example, if the interrupt (÷) key . . .'), on page 9, and 1 on page 10 ('The normal interrupt key is the division (÷) key.'). in addition to including the double-triangle key symbol at the end of the table; the equals sign looks a bit daft stuck there on its own!

This minor moan apart, I immensely enjoy your magazine (or should it be OUR magazine?) and I look forward to implementing Colin Chatfield's 'STATPACK': I am a medical laboratory research scientist, and statistics is my staple diet, along with system modelling and many other subjects which will benefit, eventually, from the programs the magazine outlines.

**Peter G.Q. Brooks**  
 20, Brasenose Driftway, Cowley, Oxford OX4 2QX.  
*PCW It's our magazine PCW*

**SUPERFAST SUPERBOARD**

Having recently made a slight modification to our demonstration Superboard and selected the best of a batch of standard 550ns memories, our board is now running at 2MHz instead of 1MHz. Running the *PCW* Benchmark tests produced the following results:—

<b>BM1</b>	less than	1 sec
<b>BM2</b>		4 secs
<b>BM3</b>		7 secs
<b>BM4</b>		8 secs
<b>BM5</b>		9 secs
<b>BM6</b>		13 secs
<b>BM7</b>		20 secs
<b>BM8</b>		4 secs
<b>BM7&amp;8</b>		24 secs

All measurements were rounded up to the next whole second to allow for reaction time errors and all tests were repeated several times to validate the results. The normal unmodified Superboard would of course produce double these timings.

It would appear from these results that in order to beat a 2MHz SUPERBOARD you would have to go for an IBM 370; which can't be bad for a home micro!

**Peter S. Fawthrop,**  
 Calderbrook Technical Services,  
 1 Higher Calderbrook, Littleborough, Lancs.

*PCW The Benchmark tests were first published by "Kilobaud" magazine, and our test results are collated or obtained by Consultant John Coll. PCW*

**A tighter plot**

Having been interested in plotting graphs of experimental data and in drawing pictures of molecular structures on micro-computer screens, I have examined a number of microprocessor systems closely for their graphic capabilities. I would therefore like to point out a number of omissions in Dr. Beynon's article (*PCW*, May) "The Sorcerer's Wand" with regard to the capabilities of the PET.

1. The Pet does have quarter square characters; we regularly plot data at a resolution of 80 by 50 using these and elementary Basic programmes.
2. The Pet also has eight x eight dot matrix pictures, so the "impossible dream" figures should be (40 x 8) by (25 x 8).
3. The Pet has 16 very useful characters which are similar to that defined in the article, i.e. a horizontal line across the

character space in any of 8 positions, and similarly vertically. So by selecting the right characters, which do not need to be specially defined, it is possible to use a resolution of either 320, 25; or 40, 200. This may not be quite as good as the 64, 240 pictures shown, and of course instead of dots one gets short horizontal (or vertical) lines, but it is still very useful.

Perhaps I could point out that we have published a design for a cheap 256 x 256 point addressable graphics peripheral which would operate on any microprocessor\*; the current cost of the hardware should be well under £200, and we have used it in research applications for nearly a year now. We still hope for a similar unit to be available commercially to save us building more, but so far the only British one is in the £2000 region and cheaper American units seem to be reluctant to cross the Atlantic.

\*A graphics oriented data collection unit — K. Stewart and J.S. Littler, "Microprocessors" 2, 139-145 (1978).

**John S. Littler**  
 University of Bristol  
 School of Chemistry, Cantock's Close, Bristol BS8 1TS.

**State your art**

As the indirect instigator of B.A. Martin's letter (*PCW*, February) correspondence, I feel compelled to say a few words. Firstly, who is to say what 'state of the art' is? Any design using 'state of the art' devices will:—

a/ be expensive since if you want to be truly 'state of the art' you must buy your devices at the early expensive stage of the cost curve, otherwise . . .

b/ if you wait for a better price, then your device will no longer be 'state of the art'! I think that we are in danger of becoming akin to the hi-fi fanatic who updates his equipment at the merest whisper of so-called improved performance and as a result misses the whole point completely.

However, it is right to examine periodically all possibilities but, even now, I rule out 16 bit machines for most people who want to get into personal computing the DIY way. The reason is simply cost: you will need twice as much memory, more power supply capability, etc; and I presume that most people either DIY because they like designing things (in which case, they are unlikely to be interested in any design published in *PCW*) or because it's cheaper — ergo, cost of 16-bits rules it out.

Do we go to the other extreme a la 77-68? Well, yes, there probably will be some interest for such a system, but I wonder just how much and for how long. Where do we go? There are, it seems to me, two groups to cater for. First, those who want to design their own but don't or aren't sure how to. *PCW* is about the only magazine that is catering for that need. Second, are those who want to buy a kit that can be expanded in easy stages and that includes, for example, a simple VDU with alpha-numeric display semi-permanently on the top line and a cheap light pen in lieu of a keyboard (which could be bought later on). However, there have been three kits produced of similar type already (NASCOM, TRITON and currently one in Wireless World) so any new design must either be innovative or be state of the art (again?) or be dirt cheap. P. Tilsley (*PCW* May '79) made a good suggestion that a centre should be set up to draw up a spec. for a reasonable all-round personal computer. Well, I am prepared to act as that centre but I bet I don't get more than twenty replies. What I want to know is what you want in the way of:—

- a/ minimum system to start with
- b/ your anticipated maximum (and if you say twin floppy discs then I will expect you to justify your extravagant desire!)
- c/ preference for processor — again justify
- d/ features the monitor should have
- e/ resident high-level language
- f/ complete kit or just pcb or just design notes.

Please send your specs to me at my address (preferably typed) but if you want a reply, then please enclose an sae. Closing date is August 1st, so come on, put pen to paper. *PCW* will give a prize of £30 for the most realistic and best reasoned specification and I will publish the findings.

**Mike Dennis**  
 "Blackberries" Sherriffs Lench, Evesham, Worcs.  
 Tel: Evesham (0386) 870841



# PETALECT ELECTRONIC SERVICES LTD

## PET 2001/8 Micro - Computer

### WHY BUY A MICRO COMPUTER FROM US? BECAUSE:

- 1) Established Company trading since 1971
- 2) Electronic servicing is our speciality
- 3) We have in house programmers/systems analysts
- 4) We have our own service engineers
- 5) We will demonstrate the PET at your premises
- 6) We can customise the PET to your requirements
- 7) We can arrange finance
- 8) We offer, after the three month warranty, an annual service contract from £69.50
- 9) You benefit from our experience of having sold over 150 Micro Computers to industrial, educational and business, personal users.

### VISIT OUR SHOWROOM AT:

34, Chertsey Road, Woking, Surrey.

We supply the full range of C.B.M. PET Micro-computers. We also supply:

Dual Floppy Disks	£820.00
24K Memory Boards	£320.00
All types of Printers	from £450.00
All types of Printer Interfaces	
Electronic balance Interfaces	
Programs from C.B.M., Petsoft, Gemsoft. We also offer a full consultancy and programming service. We are developing a number of our own business packages for all applications. Books on Basic, Programming, Interfacing etc.	
Full range of KIM's available. Tandy & ITT 2020 available. Maintenance, Hire purchase facilities as well as ACCESS and BARCLAY-CARD available.	

FACTORY: TELEPHONE WOKING 69032/68497/20727

SHOP: TELEPHONE WOKING 23637

### WHICH BRITISH SYSTEM CAN OFFER THE FOLLOWING

- COLOUR — Aerial input, Alphanumeric and Graphics
- CEEFAX — B.B.C. Television Teletext service
- ORACLE — I.B.A. Television Teletext service
- BASIC — ROM — Resident interpreter
- MONITOR — Motorola 6800 Machine Code.
- VIEWDATA — Instant information service.

T.E.C.S.

TECHNALOGICS  
EXPANDABLE  
COMPUTER  
SYSTEM

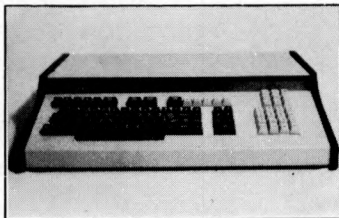

PRICES START FROM AROUND £360  
RACK MOUNTED AND TABLETOP VERSIONS  
(illustrated)

— THE LOGICAL DEVELOPMENT EVERYONE  
HAS BEEN WAITING FOR.

Please send large S.A.E. for details to:

## TECHNALOGICS

(Dept. PCW)  
8 EGERTON STREET,  
LIVERPOOL L8 7LY

## TRS80 SPECIALISTS

### BUSINESS SYSTEMS

#### Hardware

TRS-80 Level 2 16K	£611.16
Expansion Interface 32K	£386.65
TRS-80 Printer (friction)	£790.00
Teletype 43 for Pet or TRS-80	£845.00
Memory Expansion Kit	£ 76.70
Bulk Erasers	£ 5.52
Rostronics system desk mc, cooling fan (white or mink)	£183.00

#### Software

<b>PAYE payroll disk system for TRS-80 requires minimum of 32K</b>	<b>£100.00</b>
New DOS. Third generation disk operating system for your TRS-80. Corrects over 70 errors and omissions in TRS DOS 2.1	£ 25.00
Adventure tape — Treasure Unit or Adventure Land — 32K Level II	£ 10.00
Round the Horn 16K Level II	£ 5.00
Dog Star Adventure 16K Level II	£ 5.00
Star Trek III 16K Level II	£ 8.00

Over 100 other games in stock.

## ROSTRONICS COMPUTER CENTRE



118 Wandsworth High Street, London SW18  
Tel: 01-870 4805 Telex: 8813089 (Interprem)

Send stamped addressed envelope for complete price list including discount books.

(Prices exc. of VAT)

# ANADEX D.P~8000



## COMMERCIAL PRINTER

Heavy Duty Printer  
for

Pet ★ SWTP ★ Horizon

Apple ★ Cromemco ★ Sorcerer etc.

80 Col. Fast 112 C.P.S. Bidirectional Printing.  
Upper/Lower Case, £ sign, Universal Interface.

Serial, Parallel & Current Loop

Complete with Plugs & 500 Sheets Paper,

Ready to Go. **£575 + VAT**

**DELIVERY EX. STOCK.**

Phone/Write for Further Details or  
Demonstration

**LONDON COMPUTER STORE**

**43, Grafton Way, London W.1.**

**Tel: 01-388 5721**

# Happy Memories

21L02 450ns 78p    2114 450ns £4.95    4116 300ns £7.45  
21L02 250ns 95p    2114 250ns £5.40    2708 450ns £6.75

TRS-80 16K Memory Upgrade Kit: £70

S100 16K 250ns Static RAM Kit: £195 With 4K £81, 8K £119

Low Profile ) Pins: 8 14 16 18 20 22 24 28 40  
DIL Sockets ) Pence: 9 10 11 15 16 18 20 25 35

Our new shop is now open at the address below. We shall be stocking a wide range of items to interest all those of you who are building or plan to build your own microcomputer, why not pay us a visit? We are open from Mon. to Sat. 10 to 6 and often much later. We stock a range of books covering fundamentals through to advanced topics (like games)

We are NASCOM dealers for the South Coast.

Do-it-yourself with our range of wire wrapping aids and materials from the O.K. corral, or Box-it-yourself with a Vero enclosure after Soldering-it-yourself with Antex.

Our stocks are rapidly increasing; please write or call for latest lists of available products. We welcome your suggestions for stock lines. What do you find difficult to obtain? (We know about buffers)

Please add 20p p&p to all order less than £10 in value. Cheque or P.O.s payable to 'Happy Memories'. Access or Barclaycard orders may be telephoned 24hrs a day.

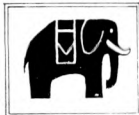

Prices quoted include VAT  
at 8% Please adjust for  
any change in rate.

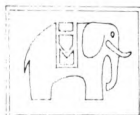

**19 Bevois Valley Road, Southampton,  
Hants. SO2 0JP    Tel: (0703) 39267**



## CRYSTAL/CC ELECTRONICS 'NASCOM' SOFTWARE

### XTAL BASIC – SPECIFICATION

This is an "8K Basic" Interpreter written for the Nascom 1 system.

1. **COMMANDS:**— Call Clear CLoad Cont CSave Read.. Data.. Restore Def.. Fn Dim Edit End For.. To.. Step.. Next Gosub.. Return Goto If..Then Input List Nas Pop New On..Goto On.. Gosub Out Poke Print Rem Run Speed Stop Wait SPC< > Tab <> Print @
2. **VARIABLES:**— Names must start with a letter, but can be up to any length. First two characters used to distinguish one variable from another. Strings of up to 255 characters, also Multi-Dim. Arrays and String Arrays. Numbers range from +/- 1E+/-38, with an accuracy of six significant figures.
3. **FUNCTIONS:**— ABS ASC ATN CHR\$ COS EXP INT LEFTS LEN LOG MID\$ PEEK POS RND RIGHT\$ SGN SIN SIZE SIZE\$ SOR STR\$ TAN VAL
4. **OPERATORS:**— ARITHMETIC : + - \* / \*\* ("To the Power of")  
RELATIONAL: <> < > >= <=  
ARITH-LOGICAL: And or Not  
STRING : + (Concatenation)
5. **CASSETTE COMMANDS:**— CSave CLoad for Saving and Loading Programs. Also CSave@ Cload@ for saving and loading of Numerical Arrays.
6. **SPECIAL COMMANDS:** EDIT – Powerful Line Editor. CALL – Machine-Code Subroutine Call, NAS – Return to 'Nasbug' Under Software Control, OUT, INP & WAIT – For Control of I/O Ports.
7. **COMPATIBILITY:**— Tape Routine Provided for Use with T2 Monitor. Fully compatible with T2, T4 & B-BUG Monitors.
8. **SIZE:**— Actually Fits in 7K of RAM (1000H – 2BFFH), but recommend >= 16k expansion Ram in your system.
9. **AVAILABILITY:**— On C12 Cassette Tape, with documentation.
10. **PRICE:**— £35 + VAT

**40 MAGDALENE ROAD  
TORQUAY, DEVON, ENGLAND  
Tel: STD 0803 22699**

## micro software systems

SOFTWARE CONSULTANTS & SUPPLIERS FOR ALL COMPUTER SYSTEMS

### DESK TOP COMPUTERS

Find it difficult to make a choice?  
Utilise our experience to make the right decision.  
Micro Software Systems Supply:

- HORIZON
- RAIR BLACK BOX
- EQUINOX 300
- COMPUCORP 600 SERIES
- COMPACT 400
- MODATA

**COMMA V.03 and other LSI BASED SYSTEMS**  
A complete range of peripherals complements this selection.

Application Software available:  
Packaged or Bespoke.

Prices from £350  
Quantity Discounts can be arranged.  
Call or write and we will be happy to discuss your problems.

**Micro Software Systems,  
Stanhope House  
Stanford-le-Hope  
ESSEX.  
Tel: STANFORD-LE-HOPE (03756) 41991/2**

# Tid Bits

## PRODUCTS . . . COMPANY NEWS . .

### Datapro has it Tabled

Datapro publishes several hundred reports annually on data processing and office system hardware, software, services and companies. There are over 35,000 subscribers to its reports, one of which, "All about Microcomputers" was sent to PCW and can be thoroughly recommended. This service is for professionals and is not cheap. Computer Information Services are agents for Datapro reports, and PCW contact with them indicates a friendly and fast service.

### Information from:

Tricia Carter, Information Director,  
CIS Ltd., 221 Seven Sisters Road, London N4 2DA  
Tel: 01-263 4441

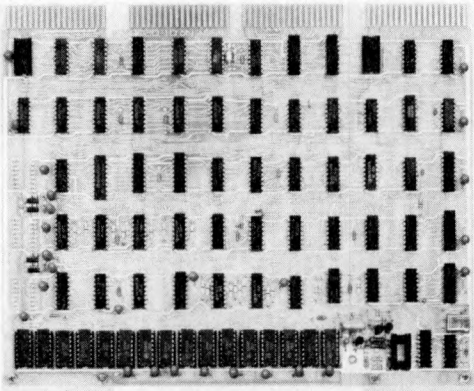

The "Univisor" — Gresham Lion's new single card computer graphics system. It will enable mini computer users to generate their own graphics using a standard TV monitor.

Contact: Russ Cockrell, Gresham Lion Ltd.,  
Gresham House, Twickenham, Middlesex. Tel: 01-894 5511

These Self-Study packages from Sybex comprise workbooks plus two to eight audio cassettes. The courses teach all aspects of micro applications. There are ten courses ranging from an Introduction to Microprocessors to interfacing techniques.



### Details from:

Sybex, 2020 Milvia Street, Berkeley, California 94704  
Tel: (415) 848 8233

### Forecasts on the Horizon

Competing with the large computers used by BBC and ITV to keep their pundits happy last Election Night, BBC Wales used an Horizon microcomputer supplied by Equinox Computer Systems to provide an instant check of all the local General Election results.

With programs developed by Dr. Martin Healey of University

College, Cardiff, the experts were able to watch the results being analysed on individual monitors.

The cost of the system at £2,000, "compared favourably with other equipment" used on the same night and reputed to have cost £250,000.

Equinox also announce that the high level language SNOBOL 4 (for string manipulation, lists, data structures and aggregates) is available on the 16-bit Equinox-300. It calls its implementation Macro Spitbol, a compiler which can be run on a minimum 64K bytes memory.

### Contact:

Michael Kusmirak,  
Equinox Computer Systems Ltd., Kleeman House,  
16 Anning Street, New Inn Yard, London EC2A 3HB.  
Tel: 01-739 2387/9.

### Plenty of Leeway

The Model 879 Serial matrix printer is a microprocessor controlled Printer suitable for use in many data processing applications with mini and micro computer systems.

Standard features: a 9 x 7 Matrix Print Head, 120 cps bi-directional printing, a 96 ASCII character set with upper and lower case and programmable extended characters, forms length and top of form control.

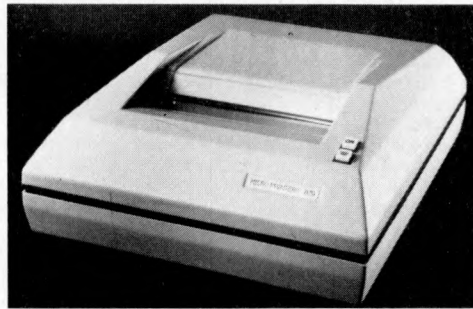

RS232C Serial Interface is supplied as standard with parallel and current loop interfaces being available as options. Baud rate is switchable up to 9600 baud and the Print Head is micro-processor controlled with a full 2 line buffer and 96 character overflow. (No price quoted to PCW).

### Further information:

Leeway Data Products Ltd., Gresham House,  
Twickenham Road, Feltham, Middx, TW13 6HA.  
Tel: 01-894 5511

### Newton's Lore of Computation

Photograph shows 320K configuration with 12 RS232 I/O Ports, a Floppy Disk Controller and Hard Disk Controller — PCB's from front to back are:

- 1 AM100, Dual Board LS11 16 Bit CPU
- 5 64Kb Dynamic Memory Boards
- 1 AM200 Floppy Disk Controller (up to 8 drives)
- 1 AM500 Hard Disk Controller (up to 4 drives)
- 2 AM300 Six RS232-port I/O Boards

All fitted in a 22 slot S100 Bus Box +PSU.

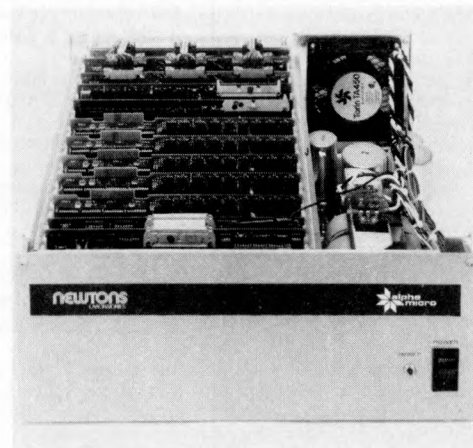

This is the Alpha Microsystem, whose UK distributor is Newtons Laboratories, 123 Wandsworth High Street, London SW18.  
Tel: 01-870 4248.

The system above is priced at £8875.

**Aiming to please**

**Portable Microsystems Ltd.** of Brackley, Northants, announce the Rockwell AIM 65 microcomputer is now available in "three important versions."

**AIM 65.** The bare-board version which is intended for the hobbyist, student or systems manufacturer who intends to develop AIM 65 into a higher level system. Prices from £249.50.

**AIM 650.** A case and a power supply unit is now available for AIM and comes complete with 4K Ram, 8K Ram Basic, power supply and desk top case. Intended for the user who prefers to have a complete package and either would prefer not to, or is unable to work at the electronics level, prices from £485.

**PDS 65.** Called PDS 65 this product takes the basic AIM 65 and enhances it to become a portable development system. For programmers or hardware designers who need to modify and debug systems at home, or at customers' premises. "The excellent documentation of this product enables the user to 'home in' on the 'target system', to allow any necessary changes to be carried out immediately."

With the use of an optional acoustic coupler the user can link up with a host system to benefit from master files or the relevant data base. Prices from £950.

**Dealer enquiries welcome.**

**Contact Mike Ayres at:**

**Portable Microsystems, 28 Broad Lane, Evenley, Northants.**

**Tel: (0280) 702017**

**Bubbling Over**

The AIM 65 microcomputer, which sells for £249.50 can now be operated with a fully addressable add-on 1 megabit bubble domain memory system.

Key to using such external memory with the AIM 65 is a buffered expansion motherboard which Rockwell calls the "AIM 65 Expansion Motherboard" and which is now offered by Pelco (Electronics) Ltd., as an option for this R6500 based microcomputer.

Originally designed as a microprocessor educational aid and R6500 Development System, the AIM 65 has been "adapted by thousands of its initial buyers to applications such as a smart terminal, a special desk top computer and a variety of process controllers."

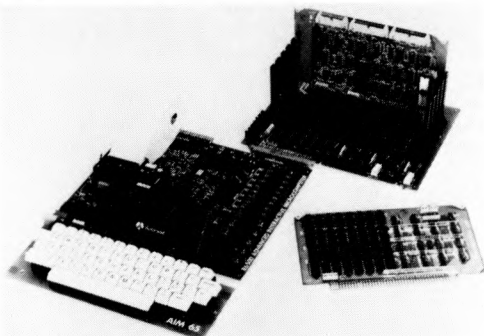

The AIM 65 expansion motherboard have five connector slots that can accommodate any of the Rockwell System 65 modules or Motorola Exorcisor modules, as well as add-on modules from Burr-Brown and other manufacturers.

The motherboard essentially extends the AIM 65 bus. System bus lines (address, data and control) are buffered to provide ample drive capability. Address decode logic for mapping internal and external addresses in 4K-byte increments is provided. Sixteen switches permit the user to define whether each 4K-byte portion of the R6502 address space of 65K-bytes is internal or external to the AIM 65.

Thus, under software control, the Rockwell megabit bubble memory module can be addressed providing 128K-bytes of memory expansion.

The unit price for the AIM 65 expansion motherboard is £136.50 and is scheduled for June delivery. Pricing of the various options that the motherboard allows can be obtained from Pelco (Electronics) Ltd., on Brighton (0273) 722155. Delivery of the AIM 65 products is now ex stock.

**Address:**

**Enterprise House, 83-85 Western Road, Hove, Sussex BN3 1JB.**

**SYNERTEK SYSTEMS KEYBOARD: 6500 Based Keyboard Terminal**

**Rastra Electronics Ltd.** of Hammersmith present the Synertek Systems KTM -2; "a high reliability low cost keyboard terminal module" providing a full ASCII keyboard and all the logic to display 24 lines of 40 characters each with full graphics.

Features: 54 keys, 128 ASCII characters (upper & lower case alpha, numeric, special and control); graphic and alphanumeric characters are capable of simultaneous display. With KTM-2's relative and absolute cursor addressing, graphs, game pieces etc can be placed and moved about the screen with a minimal amount of software.

Graphic capability, a major consideration, uses 24 lines of 40 characters. In addition KTM-2's 40 character line has a 3.2 MHz bandwidth which is within TV video capability.

In addition Rastra offer the full range of Synertek Systems with special kit prices for integral systems based on SYM-1.

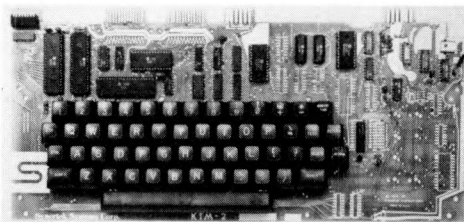

**Further details:**

**Rastra Electronics Limited, 275-281, King Street, Hammersmith, London W6 9NF.**

**Tel: 01-748 3143/2960; Telex 24443**



Left to Right: *Tony Plackowski, Mark Cooke, Coralie Cain of Tridata Micros.*

**Tridata Micros Limited** have recently opened an office in Birmingham and the address is: Smithfield House, Digbeth, Birmingham, B5 6BS. Telephone: 021 622 1754. Tridata are now marketing packages for micro computers and prices range between £100 and £200 approximately. All accounting functions are covered plus Stock Control and Payroll.

**What's This?**

It's "Whatsit": Software claimed to be guaranteed trouble-free for first time users of Apple II, North Star and CP/M™ Systems. It's a database/query system. Using simple pidgin English requests the user can store, index and retrieve information about one or more related or unrelated subjects. Systems using a minimum of 24K memory can use "Whatsit", which provides as many as 25,000 entries, each up to 200 characters in length. Utility programs are also provided, together with a comprehensive manual. (Sold by Interam in Britain).

**More information from:**

**Information Unlimited, 146 N. Broad Street, Griffith, IN46319, USA Tel: (291) 924-3522**

**The Swedes Get Personal**

A new Swedish personal computer system, the ABC 80, is composed of three units: a standard keyboard with built-in computer, a 12" B & W TV monitor, and a cassette unit. The processor used is the Zilog Z80A. Memory of 16K Bytes ROM, 16K Bytes RAM. There is a V24 jack enabling connection to a telephone modem, an "ABC bus" for connection to peripherals

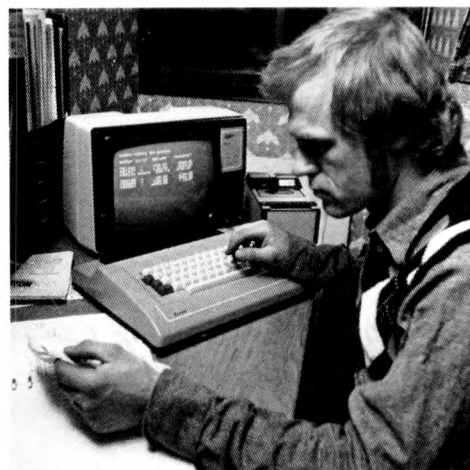

*The ABC80 from Sweden*

such as floppy-disk units, printers, plotters and measuring instruments, a real-time clock, and a loud-speaker. The ABC 80 is designed for home, educational and small business use, is programmable in BASIC, and has software packages under development. No price was quoted to PCW but details are available from:

**SATTCO AB, Dalvagen 10, S-17136 Solna, Sweden.**  
**Telex: 11 588 Phone: int +0046-8 83 02 80.**

**NASCOM DO IT — AGAIN**

The Nascom-1, which graced the first cover of PCW, has a successor, the Nascom-2, an upgraded version with more of a computing basis, and significantly more memory — a total of 20K bytes (addressable), comprising 2K monitor-in-Rom; 1K Video RAM; 1K Word Space/User RAM; 8K Microsoft Basic; 8K Static RAM/2708 EPROM. The Nascom-2 is not intended as a replacement for the Nascom-1 which, says Nascom Microcomputers, has a market for the foreseeable future.

**Focus on the Brokers**

A new "low-cost" ASCII Keyboard, the Model 771, is on offer from **Electronic Brokers**. Standard features include: full ASCII alphanumeric section; cursor control; numeric pad; two-key rollover; upper and lower case plus control codes; TTY mode for uppercase only operation; timed autorepeat on all keys; all modes standard parallel interface. At £95, the Model 771 is supplied fully assembled and tested, and there are discounts for quantity. **Electronic Brokers** are at 49/53 Pancras Road, London NW1 2QB. Tel: 01-837 7781.

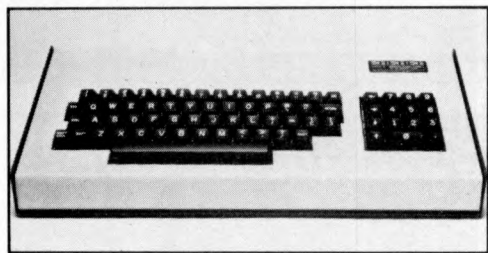

Keyboard Model KB771

The ATARI 800 home computer has just been released in the States at the West Coast Computer Faire, and has "knocked everybody sideways".



A young visitor to Thames Polytechnic has a go on a microcomputer provided by the "Selmic" microcomputer hobby group. The microcomputer workshop was open to the public

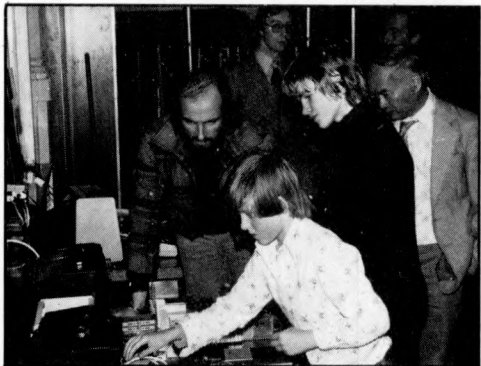

after the Annual Grace Hopper Lecture given last May by Alex d'Agapeyeff, a past president of the British Computer Society and now Chairman of the powerful Software house CAP Microsoft (UK) Ltd.



Pupils of Longfield School in Kent demonstrate their skills on a microcomputer: Front to back: Gary Googe, Robert Butler, Nigel Fuller, David Barnes, and Alan Farley. The occasion: A one-day conference at the Thames Polytechnic attended by over eighty teachers and staff from all over S.E. England.

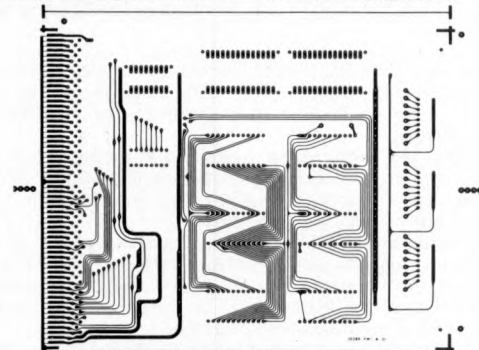

Microprocessor type read only memory printed circuit board, with provision for 3 x 8 way user programmable switches. This is a product of Shannon Circuits, which launched its UK operation on May 15. Strong backing from the Irish Export Board for this highly reputable company points to a prospering export drive for Shannon. Its UK Operations Executive is Colin East and information is available from: Shannon Circuits Ltd., 47 Hawks Mill Lane, Allesley, Coventry. Tel: (0203) 333055.

**No Tears from this Town Crier**



Publicity-conscious Tony White and Michael Monk have formed "The White Monk" company, and decided to hire the Town Crier to ring out their wares: "an umbrella information processing, instant printing and automatic typewriting service with allied mail house facilities, from production to final mailing". They expect a heavy demand for word processing, especially letter writing. Their services are available week-through, response guaranteed on Hastings (0424) 440204. Address: 9 London Road, St. Leonards on Sea, East Sussex, TN37 6AE.

**Best seller gets taped**

Adam Osborne and Petsoft have got together to put seventy six programs on one cassette. The programs are from Osborne's book, "Some Common Basic Programs" and range from small business applications to mathematical applications. The program cassette is at £15 (inc 8% VAT) and is available from Petsoft, 5/6 Vicarage Road, Edgbaston, Birmingham B15 3ES.

**Keen Computers Ltd.** are in the process of organising their own distributor network, to retail their Apple based computer systems. Applications for these Dealerships are being sorted out a full list of dealers will be published shortly.



In relation to this Distributor network, Keen Computers Ltd. are expanding their software development operations and "hope to provide an increased range of packaged software for the Apple in the immediate future."

New developments of products for the Apple II will be available shortly and these will ensure that the Apple "retains its position as market leader", whilst allowing flexibility at all levels of use.

**ABACUS SOFTWARE** announces the availability of the "PET<sup>R</sup> Machine Language Guide". This manual is intended to help the Pet owner who would like to progress beyond the Pet's native language, BASIC.

Included are sections on using the Pet's input and output routines, clocks and timers, floating point, fixed point and ASCII number conversion routines, built-in arithmetic function all from machine language programs.

There are suggestions for writing machine language programs. The sample programs are all written at a level which is simple enough for the newcomer to machine language to understand. More than 30 of the Pet's built-in routines are fully detailed so that the reader can immediately put them to good use.

The guide can be purchased for \$6.95 from: **Abacus Software P.O. Box 7211, Grand Rapids, Mich 49510, USA.**

#### Exceedingly Competitive

Exidy, Inc., the makers of the Sorcerer<sup>TM</sup> microcomputer, will sponsor a contest for microcomputer programs this summer. Four Sorcerer computers will be awarded as grand prizes.

The purpose of the contest is to encourage people who have written good programs to share their programs with other computer owners. Exidy will publish a book of the best programs entered in the contest.

The contest is open to all Basic Language computer programs which will run on the Sorcerer. The Sorcerer's Standard Basic is compatible with 4K and 8K versions of Altair Basic which have been in use since the early days of microcomputing.

Prizes of free computers will be awarded to the program judged best in each of four categories: Business, Education, Fun & Games and Home/Personal Management. Every entrant will be rewarded with a free poster and professionally-written program in trade for the program they submit.

The contest will run from June 1 through August 31, 1979.

#### Further Information:

**Mr. Paul Terrell, Marketing Communications,  
Exidy Inc., 969 W. Maude Avenue,  
Sunnyvale, California 94086, USA.**

#### Businessman's newsletter

The "Business Computer Newsletter" is intended for the business executive interested in computerising his company. It claims it will be free of jargon and full of help and advice. On its editorial board is Malcolm Peltu, who was for some years the highly capable editor of "Computer Weekly".

#### Enquiries to:

**Hulton Technical Press Ltd., Warwick House,  
Swanley, Kent BR8 8JF.** (The newsletter subscription is £32 per annum).

#### A stimulating initiative

The Manpower Services Commission is to fund a £11 million three-year programme, introducing new courses, to stimulate computer training and reduce the shortage of skilled staff. An extra 2500 to 3000 training places will be created in each year of the programme's three-year period. The three new types of course will be: 1) An initial Programmer Course of 42 weeks, 24 of them practical experience. 2) A Real Time Programmers Course, lasting 24 weeks. 3) A systems analysis course of ten weeks.

**Enquiries (from Companies and Colleges) to:  
Manpower Services Commission, Selkirk House,  
166 High Holborn, London WC1V 6PF.**

#### A dazzling new Cromemco

The Cromemco Z-2H is about to be introduced into the UK. Its outstanding feature is an integral 11-megabyte hard disc system. The Z-2H will be marketed by an independent distributor, **Complete Microsystems Limited.** Priced at £5748, the Z-2H also has a 4MHz Zilog Z80A processor, two floppy disc drives, 64K RAM, RS232 serial interface, and a printer interface. The whole computer is housed in a compact single table-top cabinet. Software, at £65 per item, includes: ANSI Level I Cobol; Fortran IV compiler; Z-80 Macro Relocating Assembler; 16K Extended Basic; Database Management System; Word Processing; Trace System Simulator; TV Dazzler Games; Dazzler Graphics.

#### Enquiries to:

**Micro Centre, 132 St. Stephen Street, Edinburgh EH3 5AA.  
Tel: 031 225 2022.**

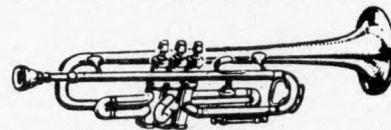

#### TRUMPET, VOLUNTARY

Responding to TIDBITS information or an advertisement?

Say you saw it in PCW  
Blow your own trumpet.  
Mention your magazine.

## PHREAKSTEIN

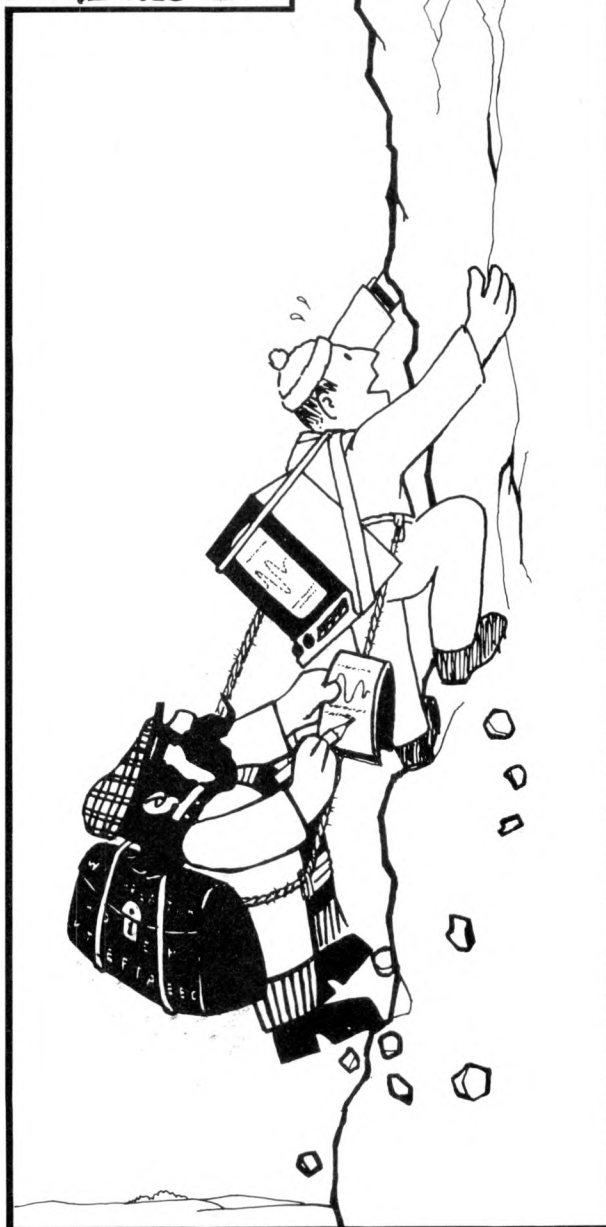



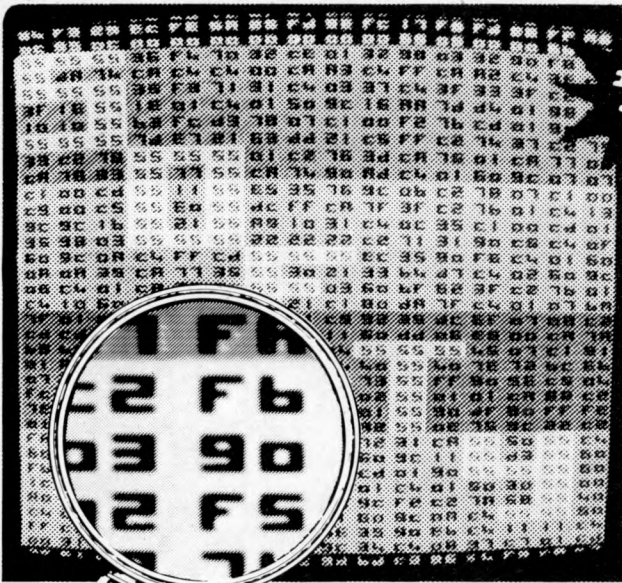

**£79.50  
+ VAT**

# A NEW TOOL FOR A NEW TECHNOLOGY

**SOFTY is not just another training aid for the engineer wishing to become acquainted with microprocessors - it is a BENCH-TOOL for the system designer.**

*"A revolution will probably take place soon, with the appearance of complete development systems costing less than £1,000 ..."*



Until quite recently all the electronics design engineer really required was a scope and a meter. Now even the smallest of companies are investing thousands in microprocessor development laboratories — afraid of being left behind in the technology-race. But SOFTY is here to help, and a microsystem can be developed without expensive equipment right through the design and prototype stages and even into production.

**WHAT SOFTY WILL DO**

- IT COPIES MEMORY DEVICES (ROMs &c) presenting the data as an address-mapped hexadecimal display on the screen of a monitor or TV set.
- IT DEVELOPS PROGRAMS for virtually any microprocessor with facilities similar to an ASSEMBLER: you may enter, insert or delete instructions, shift blocks of data, match specific bytes, calculate displacements to labelled locations — and all with the overwhelming advantage of being able to test the program instantly and even develop it one instruction at a time!
- IT RECORDS PROGRAMS on ordinary cassette tape using an ordinary cassette recorder at ultra-high-speed — around 2000 baud equivalent!
- IT PROGRAMS EPROMS of the 2708 family at a speed which is close to the theoretical minimum (2 mins per 2708). It may therefore be used as an 'instant-copier' for software.
- IT IS A HANDY COMPUTER which may be programmed to do useful jobs in the home or workshop, and may even be included as the 'brains' of larger equipment, performing sequential or combinatorial control functions. SOFTY has a microcycle length of exactly one microsecond and there is a programmable timer. The manual lists a simple interpretive language which anyone may learn to use in ten minutes!
- IT IS A FABULOUS LEARNING AID because the trainee can actually see what is happening — SOFTY is completely transparent! The internal MPU will cease execution at a breakpoint, which may be substituted for any program step, and display contents of internal registers.
- IT FILLS THE GAP BETWEEN THEORY AND PRACTICE for the serious user who already has a computer and dedicated assembler to develop his software. The computer makes documentation — not prototypes. SOFTY places the program in addressing space to be actioned by the MPU of his choice in a real system — the proof of the pudding! Simple debugging and condensing of code may often be handled without recourse to the assembler.

SOFTY can be assembled in a couple of hours. No extras are required except for a power supply providing +5, +12 & -5 volt rails and +30 volts for the EPROM programmer. The kit includes sockets for all the 23 ICs, UHF modulator for TV use, 4MHz crystal, DIN socket and lead for cassette interface, 21 key keyboard, a quality double-sided PCB of fibreglass with solder mask and component overlay and a comprehensive manual covering assembly and use.

A DEVELOPMENT KIT is also available which includes all of the above and a lever-operated ZERO INSERTION FORCE SOCKET for the EPROM programmer, 43 way card edge connector, ribbon cable and 24 pin header (for connection to the system under development as firmware) and a spare 2708 EPROM.

It is not possible to present a full technical specification in the space available here. We will therefore send you a SOFTY on the understanding that you may examine it and read the literature and, if you wish to do so, return the goods for a complete refund within 14 days.

**VIDEOTIME PRODUCTS, 56, Queen Road, BASINGSTOKE, Hants, RG21 1RE**  
**TEL: (0256) 56417    TELEX: 858747.**  
 We welcome Barclay & Access orders by telephone.

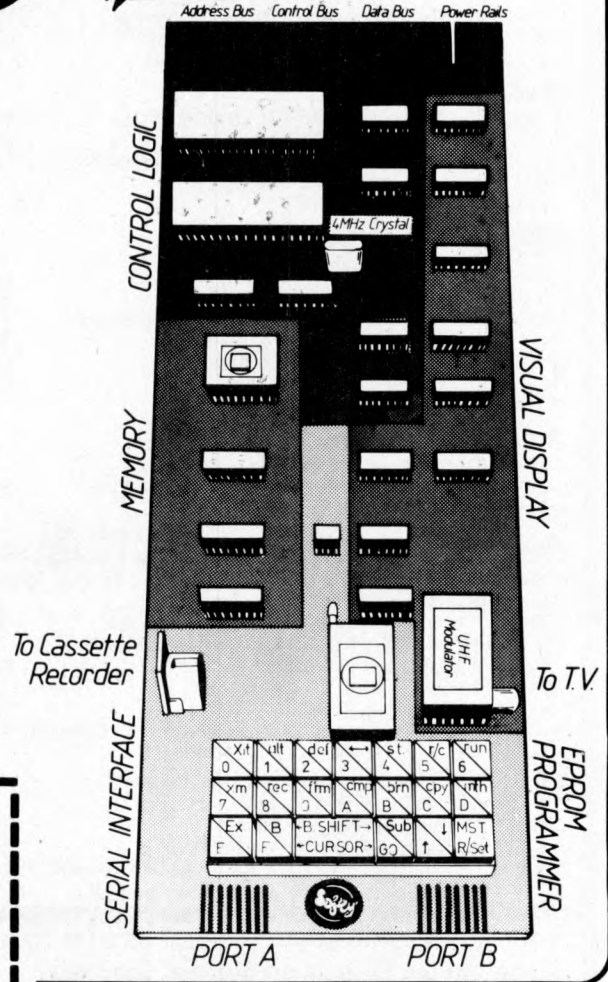

Please send me: (I enclose Cheque/Company Order)

- ..... SOFTY Kits @ £86.36 (Incl. VAT & 50p p & p)
- ..... DEVELOPMENT Kits @ £106.88 (Incl. VAT & 50p p & p)
- ..... BUILT DEVELOPMENT Kits @ £128.48 (Incl. VAT & 50p p & p)
- ..... POWER SUPPLY Kits @ £16.08 (Incl. VAT & £1 p & p)

Name .....

Address .....

PCW 7

VIDEOTIME PRODUCTS, 56, Queen Road, BASINGSTOKE, Hants, RG21 1RE





For Hardware, Software, Peripherals, Consultancy and Competitive Prices.

# MICROCOMPUTERS ETC (0276) 62506 (0272) 422061

Registered business name



## PET Pet 2001 From £435



NEW PET 2001 with large keyboard. From £ 630.00

PET 2001-16N (16K RAM and New Large Keyboard)	£630.00
PET 2001-32N (32K RAM and New Large Keyboard)	£750.00
PET 2001-4 (Standard PET with 4K memory)	£435.00
PET 2001-8 (Standard PET with 8K memory)	£515.00
PET 2040 (Dual Drive mini-floppy 343K User Storage)	£745.00
PET 2023 (80 col. dot matrix printer with PET graphics)	£515.00
PET 2022 (as above with tractor feed)	£605.00
IEEE/RS232 Serial Interface 'A' Output only	£106.00
IEEE/RS232 Serial Interface 'B' Input/output	£186.00
IEEE-488/Centronics type parallel Interface	£45.00
PET C2N External Cassette Deck	£50.00
Interface to S100 (4 slot motherboard)	£112.00

### Sorcerer

Now with the S100 Bus Expansion Interface and Dual Drive min-floppy Disk

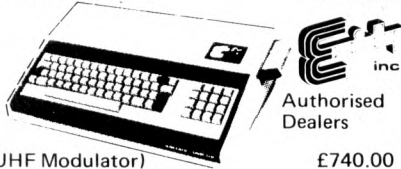

Authorised Dealers

Sorcerer 16K RAM (inc.UHF Modulator)	£740.00
Sorcerer 32K RAM (including UHF Modulator)	£840.00
Exidy Video Monitor (High Resolution)	£240.00
Exidy Dual Drive mini-floppy disk (630K Storage)	£1200.00
Exidy S100 Bus with Interface+Motherboard+PSU	£200.00
Exidy Mini-floppy Disk Drive (143K Storage)	£495.00

### Disk Drives

Shugart Mini-floppy Disk Drive (including PSU)	£350.00
Micropolony Mini-floppy Disk Drive (incl. PSU)	£350.00
Percom FD200 Mini-floppy Disk Drive (including PSU)	£350.00
Pertec 10MB Top Load Hard Disk System (with controller+disk basic)	£6400.00

## APPLE II/ITT 2020

Apple mini-floppy Disk Drive (116K Storage)	£425.00
ITT 2020 incl. PAL Modulator (16K RAM)	£895.00
RS 232C Serial Interface for ITT 2020 Motherboard	£110.00
Parallel Output Interface for ITT 2020 Bus	£95.00
Palsoft on ROM Board (extended Basic)	£110.00
RAM Upgrade (16-32K, 32-48K)	£110.00
ITT 2020 Authorised Dealers	

### Advanced Systems

Altair, Equinox, Billings, Heath, Rair, Horizon. Installations to include hard disk, and multi tasking P. O. A.

### Software

<b>Petsoft COMPUSSETES</b> Personal Software	GEMSOFT
<b>Lifeboat Associates</b> (Authorised Dealerships, Send for Catalogues)	
PILOT (for TRS 80) text orientated language	£18.00
COMAC - Computerised Accounting for TRS 80	£50.00
STOCK CONTROL - (for TRS 80) incl. Inventory, Purchase Orders and Invoicing	£125.00
CP/M for TRS 80	£95.00
CBASIC for TRS 80 & Sorcerer	£75.00
Estate/Employment Agency Systems, Fortran 80, Cobol 80, Pascal	

### Etc.

Diskettes 5 1/4 (blank) boxed (min. order 10) each	from £3.00
C60 Cassettes (Min. order 10) each	£0.40
CBM KIM 1 Microcomputer System	£94.00
Computalker Speech Synthesis for S100	£350.00
Books - Large range of Microcomputer related books & magazines.	

If you don't see it - ask if we have it.

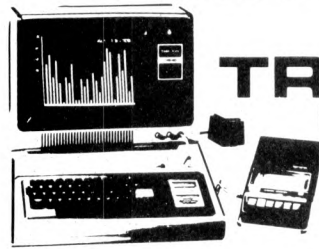

## TRS 80 From £350

TRS 80, 4K Level 1 (Keyboard with 4K memory+ VDU+Cassette drive+240v PSU)	£435.00
TRS 80, 4K Level II (as above but with Level II basic)	£535.00
TRS 80, 16K Level II (as above but with 16K memory)	£645.00
TRS 80, 4K Level I - Keyboard+240v PSU only	£350.00
TRS 80, Expansion Interface with 16K RAM	£325.00
TRS 80, Expansion Interface with 32K RAM	£435.00
TVJ 232T Serial Interface for TRS 80	£45.00
TRS 80 Screen Printer (text+graphics) (110V)	£445.00
Expander Black Box Interface for TRS 80	£48.00
Expander Black Box Power Supply for TRS 80	£49.50
Centronics Parallel Printer Interface for TRS 80	£45.00
TRS 80 Voice Synthesizer	£345.00
TRS 80 Numeric Key Pad supplied & fitted	£89.00
New Radio Shack Micro Printer	£245.00
Radio Shack Phone Modem	£160.00
NEWDOS Super-enhanced TRSDOS	£50.00
Level III Super-enhanced BASIC	£34.00
RSM Assemble/Monitor on Disk	£25.00
MICROCHESS or SARGON CHESS Cassette/Disk	£14.00
Disk Drives for TRS 80 - see Disk Drives	
UHF Modulators (encased with leads for 625 lines)	£20.00
RAM upgrade (4-16K, 16-32K, 32-48K)	
Supplied and fitted at our premises	£110.00
Upgrade to increase speed 1.78 MHZ to 2.66 MHZ	£13.00
Switchable selection of Level I or Level II (ROMS required)	£25.00
Automatic volume control (AVC) for CLOAD	£25.00
'Electric Pencil' text/word processing package (on cassette)	£65.00
'Electric Pencil' text/word processing package (disk version)	£115.00
'Electric Pencil' keyboard mod. to give lower case with text/word processing package.	£28.00
S100 Interface for TRS 80	£375.00
'Library 100' - 100 progs for TRS 80 on cassette (Level II)	£39.00

### Printers

TELETYPE 43 KSR	£875.00
Keyboard send/receive Serial printer for PET or TRS 80 (interfaces or friction feed extra)	
Teletype 33 KSR Serial (110 Baud) Reconditioned	£550.00
Expander Black Box (80 column impact printer)	£375.00
Centronics 779 parallel (friction feed)	£790.00
Centronics 779 parallel printer (tractor feed)	£890.00
Centronics 701 parallel printer, Bi-directional+ tractor fed	£1375.00
Centronics micro printer (20, 40, 80 columns selectable)	£395.00
QUME or DIABLO daisy wheel serial printers	P. O. A.

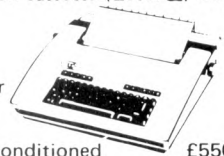

### Terminals

Soroc IQ120 VDU/Keyboard - 80 char./24 lines	£660.00
Cypher CUB VDU+separate keyboard	£380.00

Ansaback 'Phonemate' Telephone Answering Machine, voice operated twin cassette £190.00

PRICES EXCLUDE VAT, FREIGHT & HANDLING. SEND OR PHONE FOR PRICE LIST & BROCHURES (All prices correct at time of compilation)

Directors: Dr. R.V. King, BA, MIEE. S.G. Johnson, BSc. (Hons.) T.S. Johnson, ABIBA, ACMB, FBSC, MBIM A.S. Barton, ACII, ABIBA, CdpAF.



T & V JOHNSON (MICROCOMPUTERS ETC) LTD.

Member of the TV Johnson Group of Companies  
165 London Road, Camberley, Surrey GU15 3JS  
48 Gloucester Road, Bristol 7.

Branches at: Birmingham, Bristol, Edinburgh, Leeds, London, Louth, Newmarket, Nottingham, Oxford, Byfleet, Wokingham.

(0276) 62506

(0272) 422061

+ Ansaback eves and w/ends.

Telex 858893

Basingstoke (0256) 24787  
and Farnham (0252) 721094 (+ansaback during office hours)  
Hours of business 9.30-5.30 Mon-Fri. 9.30-1.00 Sat.

# Everything you always wanted to plug into your PET, APPLE or TRS-80\*

HARDWARE

SOFTWARE

## DOUBLE DENSITY DISK STORAGE FOR THE TRS-80 (220% capacity of Radio Shack's)

TRS-80 owners can now increase their on-line mass storage capacity to 200K bytes. How? By using the 77 track Micropolis model 1033-II dual drives.  
Cost: only £1195 for two drives.

How does it work? By writing on 77 tracks (instead of the conventional 35) with precision head positioning.

How do I use it? TVJ Microcomputers Etc. provides you with a special program to let your TRS-80 DOS know there are extra tracks. This program was written especially for Microtronix by Randy Cook, author of TRS-80 DOS.

Will the double density disk work with my Radio Shack drives? Yes, except of course for copying an entire 77 track disk to a 35 track drive.

**FORTRAN IV FOR THE TRS-80!** Finally, for high speed calculations on your micro, MICROSOFT's FORTRAN can speed up those computation-bound programs. Complete package includes compiler, relocatable assembler, text editor, and linking loader. Only £244. Also available:— CP/M + CBASIC for TRS-80 £170.

## TRS-80

- DATA MANAGEMENT/REPORT GENERATOR — easily formats disk files, allows entry, edit, delete & list of records; and retrieves data for display or calculation on screen or printer . . . . . £200.
  - ELECTRIC PENCIL — powerful word processor allows full cursor movement, insert/delete, string search, block movement, adjustable line length, justification (on cassette) .£65.
  - LOWER CASE MOD KIT FOR ABOVE . . . . . £28
  - DISK BASED WORD PROCESSING PACKAGE. . £124.95
  - RSM-2D DISK MONITOR — powerful system manipulates disk data, has Z-80 breakpoint routine. . . . . £25
  - ESP-1 EDITOR/ASSEMBLER . . . . . £29.95
  - RSM-IS MACH, LANGUAGE MONITOR tape base. £23.95
  - DCV DISK CONVERSION UTILITY — use with TAPE-DISK utility to save system tapes on disk (i.e.) Pencil. £9.95
  - UTILITY PACK 1 — a) Libloader merges from tapes b) Renumber (spec. mem. size); Statement analysis for debussing.....£9.95 ea. all 3 for £24.95
  - SARGON CHESS — 16K lv II — the 1978 champ . . . £14
  - MICROCHESS 1.5 by Jennings — 4K any lev . . . . . £14
  - LIBRARY 100 — an assortment of 100 programs for . £39
  - MAZE — random maze on the TRS-80 graphics. . . . £14
- Ask about our COMPLETE BUSINESS SYSTEM

## PET

- JOYSTICK PACKAGE — complete with connector, software, instructiond . . . . £39.95 single, . . . . £59.95 dual.
- MICROCHESS 2.0 by Jennings . . . . . £14
- ASTROLOGY/NATAL PACKAGE — sophisticated chart computation with PET graphics . . . . . £14.95
- SUBS — best graphics yet — drop depth charges on the subs below you and rack up points. Complete adjustability for many same variations. . . . . £19.95
- SUPER MAZE — 2 games in 1: Tunnel vision lets you travel through the maze in perspective with graphics, also Kat'n' mouse chase. . . . . £19.95
- 74 COMMON BASIC PROGRAMS on 1 tape . . . . . £15
- 19 different games at . . . . . £9.95

T & V JOHNSON (MICROCOMPUTERS ETC) LTD.  
Member of the TV Johnson Group of Companies  
165 London Road, Camberley, Surrey GU15 3JS

**(0276) 62506**



microtronix

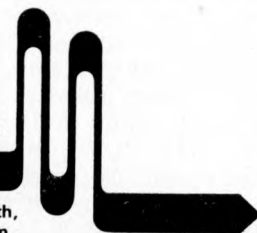

From left to right, Alan Barton, Dr Roy King, Terry Johnson and Steven Johnson, the directors of T. & V. Johnson (Microcomputers Etc.) Ltd. Trading as TVJ MICROCOMPUTERS ETC, they are currently retailing a very wide range of micro-computer hardware and software from their new showrooms at 165 London Road, Camberley, Surrey.

Branches at: Birmingham, Bristol, Edinburgh, Leeds, London, Louth, Newmarket, Nottingham, Oxford, Byfleet, Wokingham.

# In which Language should I program my Microcomputer ?

Martin Beer

*University of Liverpool, Computer Laboratory*

For some time now the advantages of using a high-level programming language, rather than Assembler, have been apparent to most microcomputer users. Programs are far easier to read and understand, making it easier to write, or modify, programs to work on any particular computer.

The language chosen by most microcomputer manufacturers has been BASIC, since it is considered by many to be the easiest computer programming language to learn, and can be implemented on current microcomputer systems very economically. BASIC statements are readily recognisable, and can be executed either as part of a program, or immediately, in calculator fashion.

This not only aids writing your program, but also debugging, and possible later alterations or additions. Unfortunately there is no generally recognised standard for BASIC, as anyone who has tried to transfer a program from one microcomputer to another will have found.

Another unfortunate feature of BASIC is the use of PEEK and POKE commands to interface with the hardware and operating system. Not only are the codes concerned totally meaningless without the relevant manuals, but they are totally different for every machine. It would be far more helpful to provide procedures which do the machine dependent operations, which would have to be rewritten for every machine, but they would be short, easy to understand, and isolated from the main part of the program.

---

## Many Tongues

---

There are now a large number of computer languages. Some, like BASIC, have been written for general programming, whilst others have been designed to make the programming of particular applications easier. Two languages in common use on large computers are FORTRAN, for scientific, and COBOL, for business, applications. Both languages have been in use on a large number of computers for many years. It has been possible for standard sub-program libraries of useful routines to be built up during this time. This, together with access to large numbers of published programs and books describing the programming techniques most suited to programming in the particular language, are a great help when writing a new program. Unfortunately, neither of these languages are easy to instal on a microcomputer since there are minimum specifications for both languages such that only the largest systems could support useful compilers.

One language for which there are good compilers for microcomputers is PASCAL<sup>1 2</sup>. This language was developed by Niklaus Wirth about ten years ago as an aid in teaching

his students good programming methods. Later, it was implemented on a large mainframe computer. Since then compilers have been developed for most computer systems currently available. Now several compilers are being written for moderately configured microcomputer systems. There are reports in the PASCAL User Group Newsletter<sup>3</sup> that large programs written using a microcomputer PASCAL compiler developed at the University of California, San Diego<sup>4</sup> have been transferred successfully, with very little work, to one of the world's largest computers.

```

program exammarks (input, output);
const
  passmark = 50;
var
  mark, passes, failures: integer;
begin
  passes := 0; failures := 0;
  while not eof (input) do
  begin
    read (mark);
    if mark >= passmark then
      passes := passes + 1
    else
      failures := failures + 1
  end;
  write ln;
  write ln ('number of passes : ', passes);
  write ln ('number of failures : ', failures)
end.

```

Fig. 1a. The Exam Marks Program written in PASCAL.

## The Highly Scrutable Chinese

A useful subset of PASCAL can be implemented in as little memory as most BASIC interpreters. The compiler described by Chung and Yuen<sup>5</sup> does not include error recovery or allow data types other than integers, and so is not suitable for general use, but even so it is a useful guide as to what can be done when only limited machine resources are available.

```

10 PM = 50
20 P = 0 : F = 0
30 INPUT M
40 IF M < 0 THEN 90
50 IF M >= PM THEN 70
60 F = F + 1 : GOTO 80
70 M = M + 1
80 GOTO 30
90 PRINT "NUMBER OF PASSES :
"; P
100 PRINT "NUMBER OF FAILURES :
"; F
110 END

```

Fig. 1b. Exam Marks Program written in BASIC.

To illustrate the use of PASCAL two programs are included, written in both PASCAL and BASIC. The first is a count of the number of students who have passed or failed an examination. The marks obtained by each candidate are entered on the terminal and the number of passes and failures are displayed once all the results have been entered. In PASCAL this program can be written very simply using a loop starting with the statement

```
while not eof (input) do
```

This tests for end of file on the input stream. If your system does not have a simple end of file symbol, another symbol may be tested for instead. The statement following the *while* statement will be executed repeatedly until the condition *not eof* (input) is false; i.e. the end of input has been found. Since a number of steps are necessary within the loop the required program statements are enclosed between *begin* and *end* to form what is known as a compound statement. The flow of control is also made more obvious by the use of an

```
if ... then ... else ... ;
```

statement to count the number of passes and failures, avoiding the conditional and unconditional jumps required in BASIC. Finally the program is made a lot more readable by careful layout and the use of meaningful variable names.

## Declaring Constancy

In PASCAL it is possible to declare constants at the start of the program. This facility is used here to set the passmark at 50. If, at a later stage, a new passmark is decided upon, it is a simple matter to edit the program as only one line must be changed. No variable storage is used, as constants are looked after by the compiler, whereas in BASIC a variable had to be assigned the value 50.

```

function gcd (i,j : integer) : integer ;
(* i and j must both be greater than 0*)
var
  i1,j1 : integer;
begin
  i1 := i ; j1 := j ;
  while i1 <> j1 do
    if i1 > j1 then
      i1 := i1 - j1
    else
      j1 := j1 - i1;
  gcd := i1
end

```

Fig. 2a. Procedure to find the Greatest Common Divisor of two Integers, written in PASCAL.

```

1000 REM G. C. D. SUBROUTINE.
1005 REM PARAMETERS I AND J
1010 REM RESULT RETURNED IN
      I1 and J1
1020 I1 = I
1030 J1 = J
1040 IF I1 = J1 THEN 1090
1050 IF I1 < J1 THEN 1070
1060 I1 = I1 - J1 : GOTO 1080
1070 J1 = J1 - I1
1080 GOTO 1040
1090 RETURN

```

Fig. 2b. Subroutine to find the Greatest Common Divisor of two Integers, written in BASIC.

The next example is a function to obtain the greatest common divisor of two integers (figure 2a and b). The method used is to repeatedly subtract the smaller integer from the other until both are the same. This is the result. It shows the ease with which standard functions can be written in PASCAL. In the main program this function may be called very easily within an assignment statement e.g.

```
I := gcd (m,n) ;
```

whereas in BASIC the calling statements to perform the same action would have to be

```

100 I = M
110 J = N
120 GOSUB 1000
130 L = I

```

which is far less readable. Also, care will be needed in the naming of variables in both the main program and the subroutine, since all are available

to both. When a number of interrelated subroutines are involved this can be very confusing. In PASCAL variables declared within a sub-program can only be used within that sub-program, so that name clashes are unlikely to occur. If a particular variable is needed in both the main program and a procedure it must be declared before the procedure, together with the other variables used in the main program. A library of useful procedures can be built up very rapidly and added to programs automatically, when required. This is a facility that professional programmers have made good use of for many years. Routines should be included in the library to make use of any machine dependent features you use, so that if one of your programs is to be transferred to another micro-computer only these procedures need rewriting.

## Wirth It

In a single article it is impossible to do justice to any programming language, but I hope that I have given some indications of the opportunities offered by PASCAL. Byte recently ran a whole issue devoted to PASCAL<sup>6</sup>, which is well worth reading if you can find a copy. For those wishing to investigate PASCAL's potential, Wirth has written a very good advanced programming text book<sup>7</sup> using it. PASCAL offers the ability to write programs in a clear and readable form, which together with the development of program libraries will help you to program your microcomputer much more easily.

I hope in a further article (with the editor's permission) to describe some of the facilities available in PASCAL for which there are no immediate counterparts in BASIC.

## REFERENCES

- 1 K. Jensen and N. Wirth. PASCAL — User Manual and Report. Springer Study Edition (second edition), Springer-Verlag, 1975.
- 2 W. Findley and D.A. Watt. PASCAL — An Introduction to Methodical Programming. Pitman, 1975
- 3 PASCAL User Group. c/o Computer Studies Group, Mathematics Department, The University, SOUTHAMPTON, SO9 5NH. (Membership fee £4 per academic year).
- 4 K. Chung and H. Yuen. A 'Tiny' PASCAL Compiler. BYTE September — November 1978.
- 5 BYTE — August 1978.
- 6 N. Wirth. Algorithms + Data Structures = Programs. Prentice-Hall, 1976.

PCW "Structured Programming and Problem-Solving with Pascal", by Richard B. Kiebertz (Prentice-Hall, ISBN 0 13 854869 2, \$ 7.95), is highly recommended PCW

# P.E.T NEWS

# PET BOOM IN BRITAIN!

## AUTHORISED PET COMMODORE DEALERS

**Birmingham**  
Camden Electronics  
021-773-8240

CPS (Data Systems)  
021-707-3866

Taylor Wilson Systems  
Knowle (056-45) 6192

**Bolton**  
B & B Consultants  
0204-26644

**Bournemouth**  
Stage One Computers  
0202-23570

**Bradford**  
Ackroyd T/W &  
Add M/C  
0274-31835

**Brentwood Essex**  
Direct Data Marketing  
0277-229379

**Bristol**  
Bristol Computer Centre  
0272-23430

Sumlock Tabdown  
0272-26685

**Cambridge**  
Cambridge Computer  
Store  
0223-68155

**Cardiff**  
Sigma Systems  
0222-21515

**Colchester**  
Dataview Ltd  
0206-78811

**Derby**  
Davidson Richards  
0332-366803

**Durham**  
Dyson Instruments  
0385-66937

**Edinburgh**  
Micro Centre  
031-225-2022

**Exeter**  
A.C. Systems  
0392-71718

**Grimsby**  
Allen Computers  
0472-40568

**Hemel Hempstead**  
Data Efficiency  
0442-57137

**Hove**  
Amplicon Micro Systems  
0273-720716

**Leeds**  
Holdene  
0532-459459

**Liverpool**  
Dams Office Equipment  
051-227-3301

Rockliff Bros  
051-521-5830

**THE  
PET 4K  
COMPUTER  
at  
£450 (+VAT)  
it's got to  
be  
Britains  
best buy!**



## Why the PET is the number one Personal Computer

### The Self Contained PETS

The self contained PET models 2001-4 and 8 come complete with TV screen, keyboard and built-in cassette deck as well as the computer circuitry. They are simply plugged into any 13 amp mains and no special knowledge is needed for running standard programs — over 200 of which are available on cassettes.

### The Big Memory PETS

The BIG MEMORY PETS contain the same main features as for the 2001-4 and 8 models except that they incorporate a full typewriter size keyboard and have larger internal memory of 16K and 32K bytes RAM respectively.

## Professional Printers

High specification printers can print onto paper all the PET characters — letters, numbers and graphics. A tractor feed model has the advantage of accepting mailing labels, using standard pre-printed forms. The only connections required are an A/C lead and PET connecting leads. The PET is programmable, allowing the printer to format print and it accepts 8 1/2" paper giving up to four copies.

## Dual Drive Floppy Disc

The Dual Drive Floppy Disk is the latest in Disk technology with extremely large storage capability and excellent file management.

The Floppy Disk operating system used with the PET computer enables a program to read or write data in the background while simultaneously transferring data to the PET. The Floppy Disk is a reliable low cost unit, and is convenient for high speed data transfer. Due to the latest technological advances incorporated in this disk,

a total of 360K bytes are available in the two standard 5 1/4" disks. Only two connections are necessary — an A/C lead and PET interface lead.

## Software and application areas for PET

There are a large number of programs that can readily be used with the PET. Personalised programming is available from many Authorised Dealers. Over 200 programs are now available from Commodore and other software suppliers for the PET. Popular program titles include Stock Control, Statistics, Payroll, Strathclyde Basic Course, Chess, Lunar Landing and Education Packs.

### FOR THE COMMERCIAL USER

The Commodore PET offers for the first time a really cost effective business computer for use in Accountancy, Statistics, Stock Control, Payroll, Invoicing etc.

### FOR THE SCIENTIST AND THE LABORATORY

PET has a comprehensive set of scientific functions making it a far superior tool to the best programmable calculators. PET interfaces directly with hundreds of laboratory instruments. PET is an ideal industrial and commercial controller.

### FOR THE EDUCATIONAL WORLD

The extensive basic language makes PET an ideal tool for teaching computer programming. Programs can be written to "tutor" the user (pupil) in almost any discipline, including BASIC itself. And, of course, the PET can be used to take care of school records, exam results, attendance figures etc.

### IN THE HOME

The PET is an extremely creative and instructive learning medium of the future for young and old alike. There are also large numbers of entertainment programmes available including chess and space games.



**Phone about PET now!**

**CALL YOUR LOCAL AUTHORISED DEALER or in case of difficulty contact:  
COMMODORE SYSTEMS DIVISION  
360 Euston Road, London. Tel: 01-388-5702**

**London E2**  
Ragnarok Electronic  
Systems  
01-981-2748

**London EC1**  
Sumlock Bondain  
01-253-2447

**London NW4**  
Da Vinci Computers  
01-202-9630

**London SW14**  
Micro Computer Centre  
01-876-6609

**London WC1**  
Euro-Calc  
01-405-3113

**London WC2**  
TLC World Trading  
01-839-3893

**Manchester**  
Cytek  
061-832-7604

Sumlock Electronic  
Services  
061-834-4233

**Matlock**  
Lowe Electronics  
0629-2817

**Morley, W. Yorks**  
Yorkshire Electronic  
Services  
0532-522181

**Norwich**  
Sumlock Bondain  
0603-26259

**Nottingham**  
Betos Systems  
0602-48108

**Plymouth**  
J.A.D. Integrated Services  
0752-62616

**Preston**  
Preston Computer Centre  
0772-57684

**Reading**  
CSF Computers  
0734-61492

**Southampton**  
Business Electronics  
0703-738248

Symtec Systems  
0703-37731

**Sunderland** Tripont  
Associated Systems  
0783-73310

**Woking**  
P.P.M.  
Brookwood (04867)-80111

Petalect  
04862-69032

**Yeovil**  
Computerbits  
0935-26522

**North Scotland**  
Thistle Computers  
Kirkwall (0856)-3140

**Northern Ireland**  
Medical & Scientific  
Lisburn (08462)-77533



Valerie A. Downes

*Department of Computing and Control, Imperial College, London*

This is an owner's report written after two weeks' experience with the Exidy Sorcerer. It does not claim to be an exhaustive analysis of the strengths and weaknesses of this home computer, but I hope to give sufficient information to assist potential buyers in their choice.

---

### The Criteria

---

I was looking for a low cost micro-computer that was not just a toy and that would give sufficient facilities for expansion to a full diskette system via a S100 bus (when finances allow!). Already having a TV and cassette recorder in the house, I did not see why I should pay for duplicating these items, preferring to use my money to buy extra computing power or memory. The Sorcerer seemed to fill my requirements, offering a Z80 processor with 32k of user RAM, floating point standard BASIC, a full ASCII character set plus graphics on a *qwerty* keyboard — all for under £1000 (£859 plus VAT). Expansion is available via an S100 bus that allows the choice of upgrading with a number of disc systems.

In fact I ordered the 16k version (£760 plus VAT) from Factor One in Penzance and it was delivered within two-weeks (I was quoted six

weeks delivery elsewhere). The single unit comes well packed, double boxed with polystyrene padding, measures about 19" x 12" x 5" and weighs some 12lbs. It has a wipeable light brown plastic housing with a robust typewriter style keyboard and separate numerical key-pad. There are several output points arranged along the back — phono sockets for video, TV and Cassette tape outputs and for tape input (the VHF modulator for TV input is not standard but was provided and included in the price!); one 25-pin connector socket for a serial interface to drive a motor-controlled cassette or an RS232 interface; another 25-pin connector socket for a parallel data port, and an edge connector for the S100 bus in the Exidy Expansion Unit. There are also three leads, two manuals and a keyboard template — but more of these later.

To say that there is 16k of RAM is deceptive — the Z80 can address 64k bytes and the Sorcerer design allows a maximum of 48k to be provided as user workspace. The remaining 16k is used by the system and

provides a 4k power-on monitor, 4k of control areas concerned with the video display, and 8k for a control program on a ROM PAC that can be plugged into a slot in the side of the machine.

This is one of the most attractive features of the Sorcerer and a BASIC PAC is supplied as standard.

---

### Installation

---

I had only minor problems in connecting the Sorcerer to my own TV and cassette recorder. The TV, a Ferguson 12" Black and White portable, needed a phono to co-axial lead which had to be made up, since only a phone to phono lead was provided. The *mic* and *ear* leads were supplied for the cassette recorder but my first tests of saving and reloading programs all ended in the response:—

```
ERROR - TAPE CRC ERROR
>
```

which left control in the monitor and needed a PP command to return to BASIC. A subsequent list would then

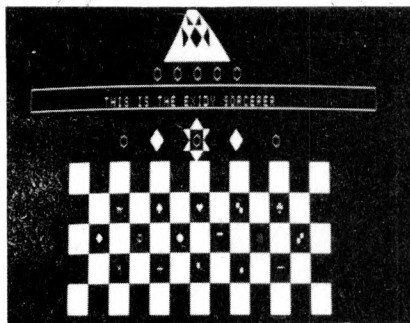

give assorted gobbledygook, ending in endless repetition of a single character, which could only be stopped by RESET. This error was not documented in the manuals and could be disconcerting. However, I decided that the problem probably lay with my rather elderly Sony TC-100A portable cassette recorder, so I gave it a good clean with cotton-wool buds soaked in methylated spirits. After this I had no further trouble except when accidentally attempting to read human speech.

With everything connected I was left with an unsightly collection of leads, particularly because each component needed connecting to the mains electricity. This could be improved by the use of a single distributor board that would also make the siting of the equipment more flexible.

---

### Documentation

The Sorcerer comes complete with two introductory manuals — 'A Guided Tour of Personal Computing', and 'A Short Tour of BASIC'. The first of these gives a chatty introduction to the equipment, simple BASIC programs and the commands available under the monitor.

Most of this book is presented in a palatable fashion designed for the beginner, but I feel that the sections on the monitor and interfacing fall between two stools: they will either frighten the novice or prove not detailed enough for serious use. The information on connecting the cassette tape recorder did not warn of the error that I encountered, or suggest trying a tape rate of 300 instead of 1200 baud, and there is no description of monitor error messages.

The manual on Basic is well presented but I found it misleading on the subject of strings. There is an unqualified statement that, "You can have as many as 255 characters in a string", which is not true under the default limit set on the string space. Only in an appendix are we told that the string space is normally set to 50 bytes. There are some

puzzling omissions like the fact that Print CHR\$(12) will clear the screen and return the cursor to the top left-hand corner. Those not familiar with BASIC will need a more detailed text book if they intend to do any serious programming.

Anyone wishing to do much outside the standard BASIC, like driving peripherals, will require further documentation such as the Sorcerer Technical Manual which is advertised in the back of the BASIC manual but is, apparently, not yet generally available.

---

### Graphics

The video display screen is made up of 30 lines of 64 characters, each character being formed by an 8 by 8 dot matrix. This gives a resolution of 240 by 512 dots over the whole screen although not every point is independently addressable. Even using a standard TV through the UHF Modulator the resolution is acceptably clear and perfectly steady, only giving slight interference when the cassette motor is on.

The display is index mapped by 1920 bytes of system memory, each of which contains the numerical coding of one of the 256 available characters given by the ASC function. Each character is stored in further 8 bytes of system memory. Values can be POKEd directly into the screen area from a BASIC program.

The Sorcerer is supplied with the 128 standard ASCII characters plus 64 predefined graphics symbols — in line with those found on the PET. By using a combination of shift keys the keyboard can also be used to access another 64 characters which can be defined by the user. By sketching the shapes required on graph paper one can work out the pattern of dots required, convert them to hexadecimal and load them into memory, either by using the monitor or by POKeIng from

BASIC. The process is well described in both manuals and can also be used to *redefine* the 64 supplied graphics characters.

Once defined, symbols for different applications — greek letters, mathematical symbols, or whatever — can be saved on tape and reloaded when required. The template of the keyboard can be used to note these special symbols — it has a wipe-clean surface, from which flow-pen marks can easily be removed, and an adhesive back for fixing to the Sorcerer's casing. These facilities are quite adequate for games, simple graphs and charts, circuit diagrams etc. although they do not compare with the high resolution graphics of the APPLE II.

---

### Plug-In Memory

One of the nicest features is the plug-in ROM PAC which contains the standard 8k BASIC interpreter. This is housed in the type of plastic container usually used for 8-track cartridge tapes but with an edge connector at the open end. It slots into the side of the Sorcerer and is given control by the monitor. This design allows one to change control programs with the minimum of time and effort, and Exidy claim that several PACs are now under development — including an assembler, word processing facilities and an APL interpreter. There will also be blank PACs available into which users can load their own programs.

However, it remains to be seen how robust this system will turn out to be under constant use which could lead to wear on the gold flashings of the connectors. The manual warns against moving the PAC in or out with the power on and I have not experimented to see what damage an accident here might cause.

---

### The Monitor

Control remains with the monitor program if a ROM PAC is missing

	BENCHMARK PROGRAMS <sup>1</sup>			
	SORCERER	APPLE II <sup>2</sup>	TANDY TRS-80 <sup>3</sup>	PET <sup>2</sup>
BM1	1.8	1.3	2.5	1.7
BM2	10.0	8.5	18.0	9.9
BM3	20.7	16.0	34.5	18.4
BM4	22.2	17.8	39.0	20.4
BM5	24.3	19.1	45.0	21.7
BM6	37.6	28.6	67.0	32.5
BM7	53.7	44.8	109.0	50.9
BM8	9.6	10.7	—	12.3

1. PCW Volume 1, Number 1 page 57/58; 2. PCW November 1978, P.52;  
3. PCW September 1978 P.28.





and it can also be entered by issuing a BYE command. It has a useful range of commands — sufficient to allow Z80 machine code routines to be loaded and executed, memory locations to be inspected to assist debugging, user defined graphical characters to be set up, and a tape of monitor commands to be set up and executed. It is through the monitor that various modes of operation can be selected — 1200 or 300 baud tape transfer rate, use of different I/O ports etc.

#### Using Basic

The standard BASIC interpreter, supplied in a ROM PAC, is compatible with floating point BASIC now offered with a number of systems of similar size. All numerical values are stored to an accuracy of six significant figures and cover the range 1.70141E38 to 2.93874E-39.

However, mathematical operations give rounding errors and it would be foolish to rely on more than five significant figures. Although there is a range of mathematical and trigonometrical intrinsic functions, serious mathematical computations could, and should, be performed far more accurately on a scientific pocket calculator than on a computer of this type.

I ran the benchmark programs listed in PCW Vol 1, No. 1 and the results are given in the table below together with those for the APPLE II, Tandy TRS-80 and PET quoted in earlier issues of PCW.

There is a random number generator which is initiated by a supplied seed, useful for simulation programs. I did a rough test by printing ten-point histograms of a run of num-

bers produced by a given seed and those tried were all reasonably rectangular after a run of 1000 numbers.

There are PEEK and POKE facilities, USR which allows entry to a machine code subroutine and FRE which tells one how much memory is left un-used. All these allow clever programming and are particularly useful for building special displays or driving peripherals.

There are string variables and various operations that can be performed upon them. But here a word of caution — in default mode the Sorcerer does not like strings, it limits each string to 50 characters and total string space to 50 bytes. This is to maximise space available for programs. However, if, like me, your first test is to type in a published program to see if it works, and that program starts with a large number of statements printing strings, then you are in for a nasty shock — the string space limit includes PRINT statements as well as variables and the first run of the program will give an "out of string" error. The default setting can be overruled by a CLEAR n statement, where n is the number of string bytes required, either as a direct command or as a program statement.

Programs can be transferred to and from cassette tape by using the CSAVE and CLOAD commands, with the tape motor being controlled by hand. An extra connection can be bought which enables the serial interface to be used to control the motor as well as transfers. However, I have not found manipulating the tape controls to be a problem; and programs can be written to issue prompts at the points where tape control actions are required. The

ability to issue a CLOAD command from within a program allows overwriting by a replacement program — and this means that suites of programs can be designed with an initial program that interfaces with the user and allows him to choose the next function.

Arrays of any size can be transferred to and from tape with the CSAVE\* and CLOAD\* commands but, annoyingly, this feature does not extend to strings or arrays of strings. I consider this to be a serious omission since many of the applications to which a personal computer will be put will involve handling character data-names, addresses, stock component descriptions etc. — which is to be stored on tape.

#### Conversion

However, this problem can quite easily be overcome, without resorting to machine code, by converting strings into their ASCII equivalents (using the function ASC), storing these equivalents in an array and then transferring the array to tape. The reverse process can be effected using the function CHR\$ which converts the ASCII code back into character form. In fact these functions do not only work on the 128 ASCII characters but also on the graphics symbols — including user defined graphics. The following short program illustrates the use of this technique.

```

10 REM EXAMPLE OF TRANSFER
  OF STRINGS TO TAPE
20 REM STRING SPACE SET AT 500
  BYTES
30 CLEAR 500
40 REM ARRAY S TO HOLD MAX 50
  CHARACTERS
50 DIM S (51)
60 INPUT "STRING"; S$
70 REM STORE LENGTH OF STRING
  IN S (0)
80 L = LEN (S$)
90 S (0) = L
100 REM STORE STRING IN S
110 FOR K = 1 TO L
120 S (K) = ASC (Mids (S$, K))
130 NEXT K
140 REM TRANSFER STRING
150 INPUT "RECORD"; X$
160 CSAVE* S
170 INPUT "OFF"; X$
180 REM REPEAT IF MORE DATA
190 INPUT "MORE DATA (Y or N)"; X$
200 IF X$ = "Y" THEN GO TO 60
210 INPUT "REWIND"; X$
220 END

```

The string can later be recalled from tape by using CLOAD S followed by:—

```

L = S (0)
S$ = ""
FOR K = 1 TO L
S$ = S$ + CHR$ (S (K))
NEXT K

```

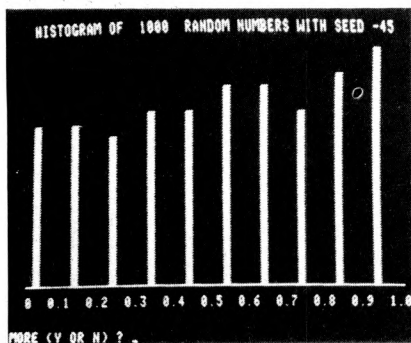

I have used this technique for a program that handles a cassette tape file of names and address. Each line of the data is input into the same string variable which is then converted into one row of two dimensional array, ready for transfer to tape. The conversion process is so fast that there is no noticeable delay in the prompts for each line of input.

To speed up the process of typing programs the Sorcerer provides almost all of the BASIC key words as single key inputs, using the GRAPHIC shift in the context of the BASIC instruction. The program looks rather strange with — for PRINT  $\pi$  for GOSUB and the like, but a LIST restores the full words.

The key words are not printed on the keys but I have copied them from the manual to my keyboard template (more than one of these would be useful). At first I found using them slower than typing the full word since I had to search for the correct key, but the positions of the commonly used words soon became familiar.

There is no line editing, hardly to be expected in an 8k interpreter, but single characters can be erased on a SHIFT and RUB and a whole line aborted with @. The control shift and C breaks into execution of a program and allows one to input directly executable statements before CONT continues execution. This facility is very useful for debugging programs, since it allows the contents of variables to be inspected or changed. If all else fails, simultaneous pressing of the two RESET keys, a good precaution, will take one back to the start of BASIC — losing any program but not user-defined graphics. Although reset is rarely necessary. I would advise frequent saving of program versions during development.

One very annoying aspect is the inability to list a program by the screen-full: the LIST command lists the whole program or from a given

line, but not to a given line. LISTings can be caught as they scroll past by pressing the RUNSTOP key but this only holds while the key is depressed. It would be an improvement if this key was fitted with a lock, like the SHIFT LOCK Key, so that both hands can be free for making notes or photographing the screen.

### Conclusion

The Sorcerer represents excellent value for money either for the home enthusiast, teacher, or small business man who wants something with expansion potential. The minimum configuration allows serial processing (if you do not mind driving the tapes by hand), the graphics potential is fine for both game playing and diagrams, the standard BASIC gives access to a large printed repertoire of established software and the ROM PAC promises easy expansion into new languages. My only words of caution would be to wait and see how durable the PACs prove and how soon the projected software actually becomes available.

Since this article was written, two months ago, Valerie Downes has attained greater familiarity with, and expertise on, the Sorcerer.

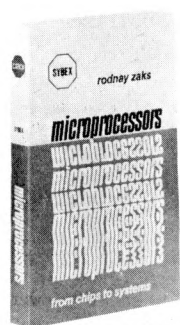

#### Microprocessors from chips to systems

This book covers all aspects of microprocessors from the basic concepts to advanced techniques in a progressive presentation. It covers standard principles and design techniques.

£8.50



#### Programming the 6502

An educational text designed to teach programming using the 6502. It does not require any programming knowledge, yet can be used by anyone wishing to familiarize themselves with the 6502.

£8.50

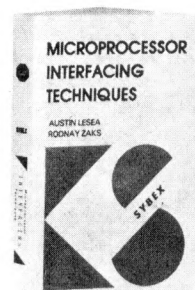

#### Microprocessor Interfacing Techniques

Introduces the basic interfacing concepts and techniques and then presents in detail the implementation details from hardware to software. Introduces basic troubleshooting techniques.

£8.50

Other books titles & magazines on application.

Name .....  
 Address .....  
 .....  
 .....

Please send me .....  
 .....  
 .....

I enclose cheque/PO No. ....  
 Please debit my Access/Barclaycard  
 Account No. ....  
 .....  
 Amount .....

All prices include VAT and carriage.

Cut out and send to:-

**Keen Computery Ltd., 5 The Poultry, Nottingham Tele: 585254/56**

# WE'LL SHOW YOU EVERYTHING

Because we've got the biggest and widest range of micro-computers, there's more for you to bite on at a Byte shop.

So you're not only sure of finding exactly what you want: you can take the opportunity to experiment before you buy.

And because we're backed by the huge financial resources of a major



investment group, we'll be here tomorrow as we are today. All over the UK.

So whether you want a micro-computer for your home, your business, for industry, for education — or if you'd just like to find out which model you get on best with — you'll find a



visit to a Byte Shop a new and invaluable experience.

You can call at a Byte Shop any time from Monday to Saturday.

the  
**BYTE SHOP Ltd**

The Byte Shop  
426/428 Cranbrook Road,  
Gants Hill, Ilford, Essex  
Telephone: (01) 554 2177  
Telex 897314

**Branches at:**  
**LONDON (WEST END):**  
48 Tottenham Court Road —  
tel (01) 636 0647

**NOTTINGHAM:** 92a Upper  
Parliament Street —  
tel (0602) 40576

**MANCHESTER:** 7-8 Corn  
Exchange Building,  
Fennel Street —  
tel (061) 834 0220

# All Systems Are Not Created Equal

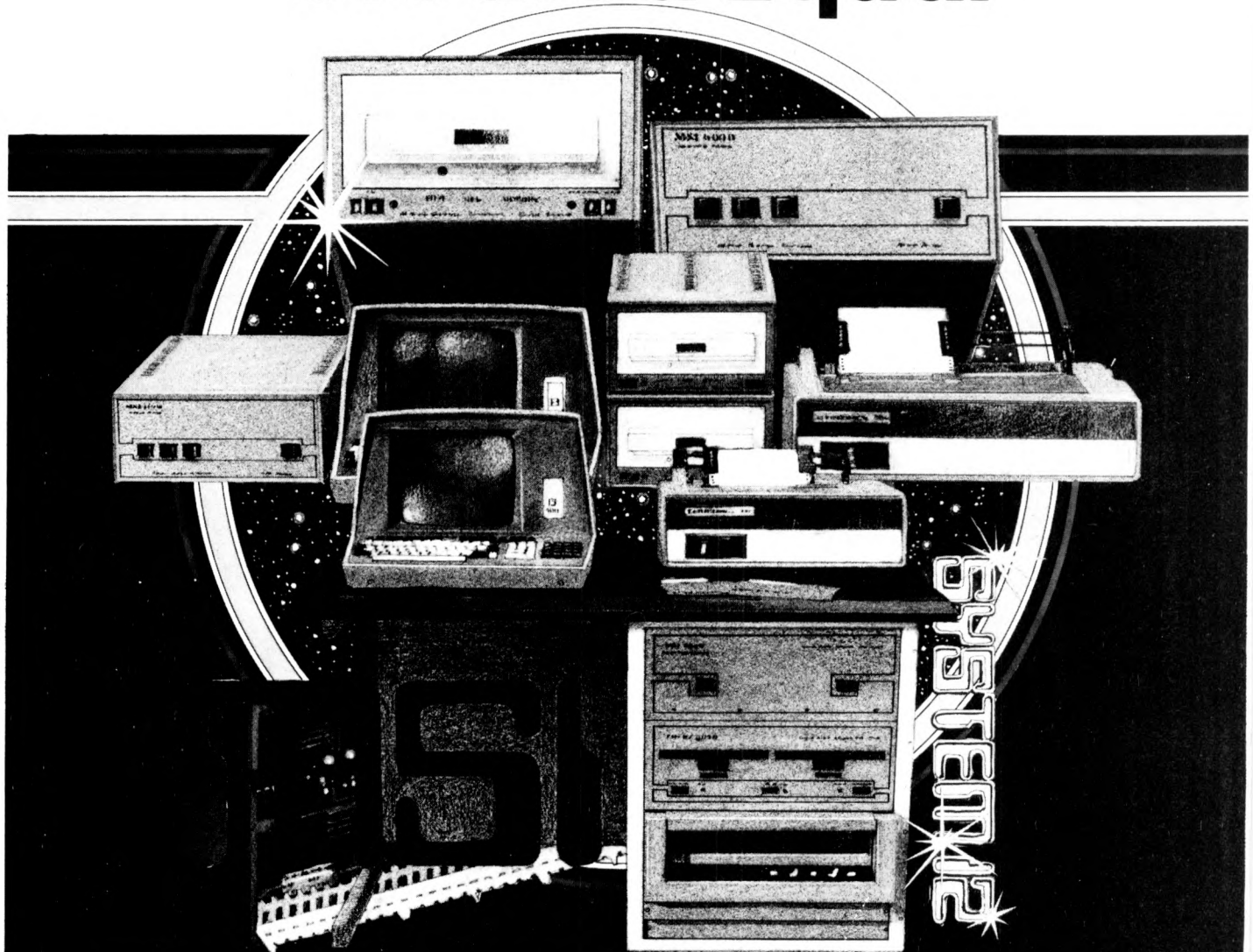

Your computer application is unique. It differs from all others. It is because not all applications are equal that MSI has developed a variety of computer systems.

At the heart of every MSI System is the powerful MSI 6800 Computer, one of the fastest and most versatile available. Depending on the System you select, the MSI 6800 has from 16K to 56K of RAM. Mass memory storage in MSI Systems range from 315K bytes in the System 1 to over 10 megabytes in our most powerful System 12.

In addition to the computer and memory subsystem, MSI Systems include a CRT terminal and high speed character printer. The System 12 is housed in a compact desk unit.

As with hardware, computer software is not always created equal. Since there are a myriad of programs available, MSI offers a choice of Operating Systems for use with your MSI Computer System. Of course, our favourite is MSIDOS, but we offer the powerful SDOS operating system as well. All MSI Systems will support the other software products associated with each operating system.

MSI also has a variety of software programs including a Multi-User Basic program capable of supporting up to four users.

MSI Systems are currently being used in a broad spectrum of personal, scientific, educational, professional, and business situations. In addition to our Systems, we

can supply you with individual components for personal and OEM use. All MSI System components are available, some in kit form.

Write or call us for more information about MSI Systems and products and the name of your nearest MSI dealer.

**seed**

Strumech Engineering  
Electronic Developments  
Portland House,  
Coppice Side, Brownhills,  
BRO 4321 Telex: 335243

# SMALL SYSTEMS ARE GOOD FOR SMALL BUSINESSES

John Braga  
Computerland, Nottingham

PCW This reasoned response to a previous PCW article is a good indication of the quality of the people engaged in the business of selling microcomputers PCW

Mr. Worsley's article in the June issue of PCW, dealing with whether or not small businesses were ready to adopt microcomputers in large numbers, raised a number of interesting points.

The fact that I disagree with most of his conclusions has prompted me to reply!

One point on which we do agree: Small businesses will turn to computers for one reason only — if it makes economic sense for them to do so. But anyone who is involved with small companies and who has had the benefit of a systems analysis training must agree that there are countless opportunities in almost every business to increase efficiency by the judicious use of computers. Mr. Worsley makes two important points with which I agree, namely:—

- most businessmen are not prone to seek innovation for its own sake; they will wait until the product is presented to them in an easily digestible form.
- However well a system is designed, installing a computer is going to be much more of an upheaval than installing dictating equipment or an electric typewriter. The smallest system may well involve a fundamental change in the way a company operates.

Many businessmen have not thought deeply about computers, believing that they are an excellent invention — for someone else! If pressed to say why they have not installed a computer they have sheltered behind three main defences; every computer salesman is only too familiar with them!

1. Computers are too expensive.
2. It is quicker by hand.
3. My business is too complicated to program on a machine.

The revolution in technology of the past two years has meant that the first argument above has been rendered totally invalid. There is now no reason why any company turning over £500,000 or so should not afford a computer system which now

costs little more than a photocopier and less than a Chairman's company car! The other two arguments will persist but are generally due to an ignorance about how a computer works.

This last point is not meant to be a criticism of businessmen in general; it is an unfortunate fact that computers are complicated to understand and to install. It is a challenge to the software house, systems analyst, micro manufacturer and retailer to make systems that are flexible and easy to use; but, since each company operates in a different way, each company will ideally want a different computer system. Some bending will therefore need to take place, and either the company or the computer system will have to adapt!

I am certain, however, that businesses will install large numbers of micros. Any system needs three ingredients: good hardware, operating system, and application software.

We already have the first two, and application software is becoming available in increasing quantities. As the professional software houses become aware of the falling price of machines we will see a large increase in the amount of good packages becoming available. No company producing systems can afford to ignore the micro market (although some have shown every sign of wishing it would go away, and leave them in peace making large margins on 'expensive' minis!) A company will be left stranded if its software will only work on a £20,000 system where the competitor's will run on a £5,000 machine.

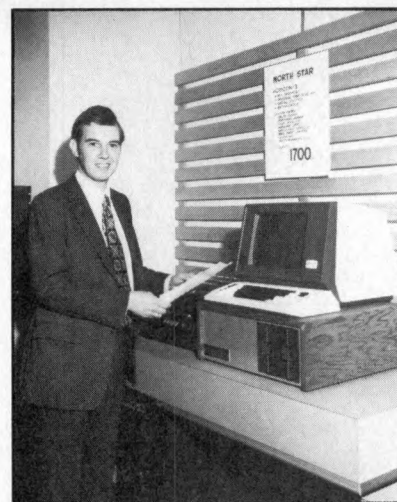

Remember too that COBOL compilers have now become available for the micro and this means that a large amount of existing software can speedily be converted to run on micros. My own company is already doing this and there are hundreds of software houses that will be doing likewise over the next few years. The market is too large to ignore.

In summary, there is no earthly reason why good software should not be available on low-priced systems. The price is likely to vary widely, depending on the size (and overheads) of the company producing it, but we are already seeing packages now available that can be safely used by the business entirely new to computers. Nor is there any reason to think, as Mr. Worsley does, that small computer companies will be driven out of the market by big companies. Small computers have several advantages when producing software for small businesses:—

1. They are small themselves and can relate to the small business's problems and systems. A rapport can easily be established between buyer and seller, which is not so common when the seller is the sales office of a large multinational.
2. They have small overheads so can frequently sell at lower margins. This also means that they can look at business which larger companies do not find profitable — remember, a large company works best by selling a standard product in large numbers, and is frequently less willing to tailor to individual requirements.
3. They can be very flexible, changing their products at short notice to meet a new market place.

For this reason I believe a professionally run small company will survive in the micro world, though it may need agile footwork at times to adjust! I also believe, though, that there are too many companies, large and small, which do not deserve to survive the next few years because they are not offering a competitive service or product.

So where does this leave the owner of a small business who is

wondering whether or not to buy a computer? Here are a few guidelines which may help him to decide:

1. Read as much about computers as you can. There are several good books and magazine articles which cover the application of small computers to business problems without introducing too much jargon.
2. Attend several different demonstrations. This will educate you in the way of different machines and — just as important — enable you to weigh up the capabilities of potential suppliers.
3. When considering what part of your business could be 'computerised', concentrate on one simple application rather than on an integrated system affecting every facet of the operation. If you devote your energies and time to getting one application up and working, your computer will be earning its keep while you are developing subsequent phases. Also, you will learn a lot from the initial stage and may well modify your subsequent development in the light of initial experience.
4. Do not try to dream up 'Your Perfect System' before the machine is even installed. You are dealing with too many variables to look ahead with precision. You must of course look ahead far enough to be sure that what you may want to do is feasible on the equipment you are considering, but what you *think* you need is probably very different from what you will *actually* want, with experience of a computer system under your belt.
5. Learn to distinguish between a micro suitable for playing Startrek and one suitable for Sales Ledger. There is a world of difference between the hobby and business system. Many manufacturers and

dealers do not distinguish, perhaps preferring to try to catch both markets with the same machine (it makes life simpler for them that way!). There are some vital differences, however, so make sure you understand them before purchase.

6. While on the subject of dealers, most people are likely to need advice and help from their supplier after they have bought. So choose him with care — if he seems more interested in the electronics of his box-of-tricks than in applying the machine to solve your particular business application problem, go elsewhere. You need the advice of a knowledgeable businessman, not an engineer, at this stage.
7. Finally and perhaps most important, never forget that in the world of micros, as in other fields, you get what you pay for! If a machine costs 50% less than another system there is usually a good reason. It always surprises me, for instance, that people expect a £500 printer to perform as well as a £1200 model and last just as long. In a fiercely competitive market prices are generally what they are for a good reason . . . All of which does not mean a cheap system need not be excellent value, but do make sure you understand what has been left out. All systems have their limitations and you should be suspicious if the salesman is too glib on this point.

The responsible dealer or manufacturer realises that by educating the computer buying business world to become more knowledgeable and critical he stands a better long-term chance of selling his products. Satisfied businesses are his best reference. So please let us work jointly to keep expectations and standards high!

## GEMSOFT

Gemsoft proudly present their new catalogue of over 50 original programs for the Pet 2001, at down to earth prices. including:

**GAMES:**— Zap the klingons, Dropout, Dominoes, Crosswords, Blackjack, X-wing attack, G.B. Quiz, Horse race. **All £6.** Arrow, Ricochet, Star trek, Explore, Traffic jam, **all £5.** Oil run, Petals, Scramble, Bagels X2 **all £4.50.**

**Educational:** Metric conversion, Curfit, Triangle, Marks, Distance calculator, Airthmetic & geometric progression **All £4.**

**Business** and general purpose programs at varying prices, including: Mailing list, Bank account suite, basic stock control, VAT returns, all available now on the Diskmon system, as well as Mortgage, Portfolio, Date calculator, Keyboard record, Line renumber, Trace, Hexconv, Tape read & write etc. on cassettes. Many more programs available, please send SAE for full catalogue, or contact your local computer shop.

**EXIDY SORCERER SOFTWARE** in preparation.

Complete systems supplied for business and educational applications based on the Pet and Exidy Micro's. Business and special applications programs written to order.

### GEMSOFT

"Alverstone Lodge," Wych Hill Lane, Woking, Surrey. (04862) 60268

# TRS 80 SOFTWARE

from the leaders in innovative software

**We** were first for the TRS-80 with Re number Basic

**We** were first with software Level 1 in Level II

**We** were first with the Howe Monitors 1, 2 and 3.

**We** were first with the Library 100 . . .

*And we are going to go on being first*

SEND SAE FOR LIST

## A.J.HARDING (MOLIMERX)

28 Collington Ave.,  
Bexhill, E. Sussex.  
Tel. (0424) 220391

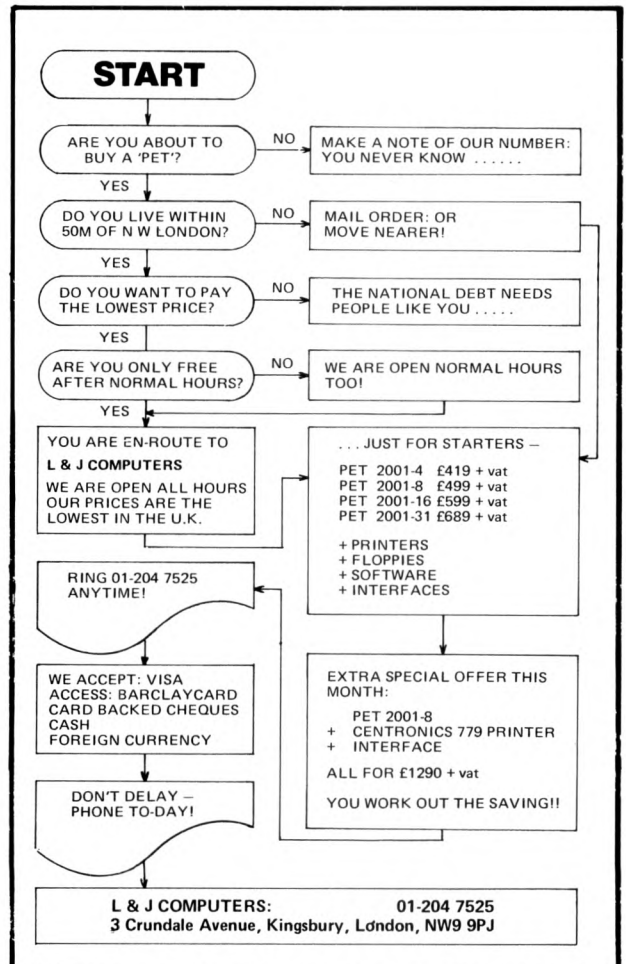

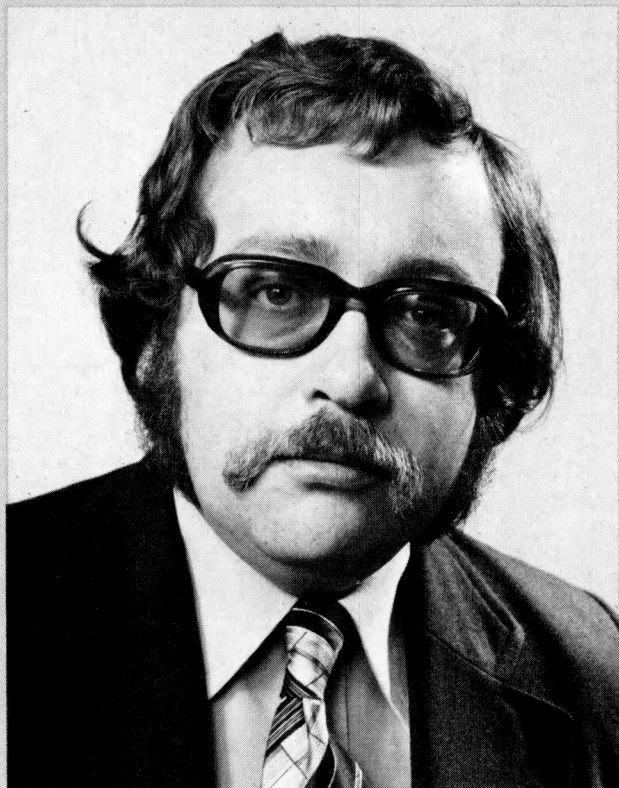

David Hebditch

# ON THE LINE

## Communications I/O

I have earlier in this series, considered:

- \* techniques for representing data bits on analogue telephone lines
- \* the use of modems and acoustic couplers for converting bits from digital form to analogue form (and vice versa)
- \* timing and character formats
- \* the V21 interface between the computer and the modem.

We have now reached the stage where I can describe what needs to be done to get a seven-bit ASCII character from the main memory of our micro-

computer across the V-series interface so that the modem can modulate it on to the telephone line. The reverse operation to get bits assembled into sensible characters is also relevant.

To save you having to revise the previous articles in the series, this is what needs to be done:

### TRANSMIT

1. Generate a parity bit and append it to the character
2. One start bit and at least one stop bit will also have to be appended.

3. The resultant framed character then needs to be *serialized*, i.e. passed bit-by-bit to the 'transmit data' lead of the interface.

The regular reader will remember that the last operation is necessary because all data transmission takes place in a *bit serial* fashion, but data is held in the micro in *bit-parallel* (or character-serial) form.

It should come as no surprise that the sequence for incoming data is:

### RECEIVE

1. *Deserialize* the bits into a 'framed character' form.
2. Strip off the start and stop bits.
3. Check the parity bit, set status accordingly (good or bad) and dispense with the bit (unless it is going to be taken all the way into RAM).

There is another important stage:

4. Tell the processor that a character has arrived.

Exactly how this is done will be dependent on the architecture of the micro being used. At a simple level, a status bit may be set. Increasingly, an interrupt may be raised.

Other things need to be done (e.g. assemble the incoming characters into a meaningful message) but the steps I have described so far are

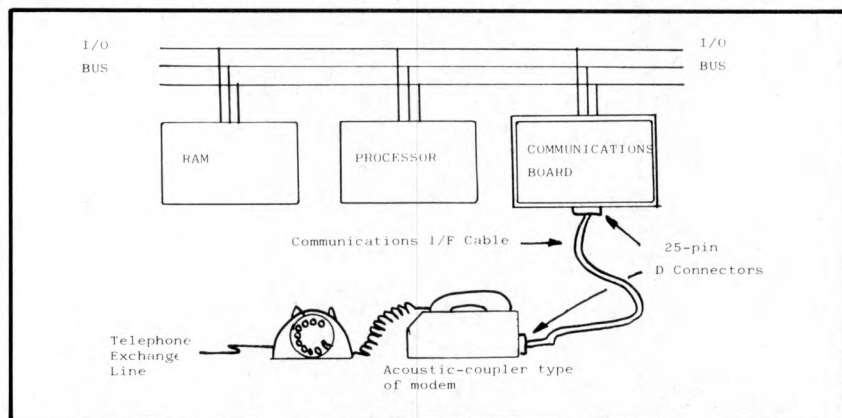

Fig. 1. Single-Line Communications Board

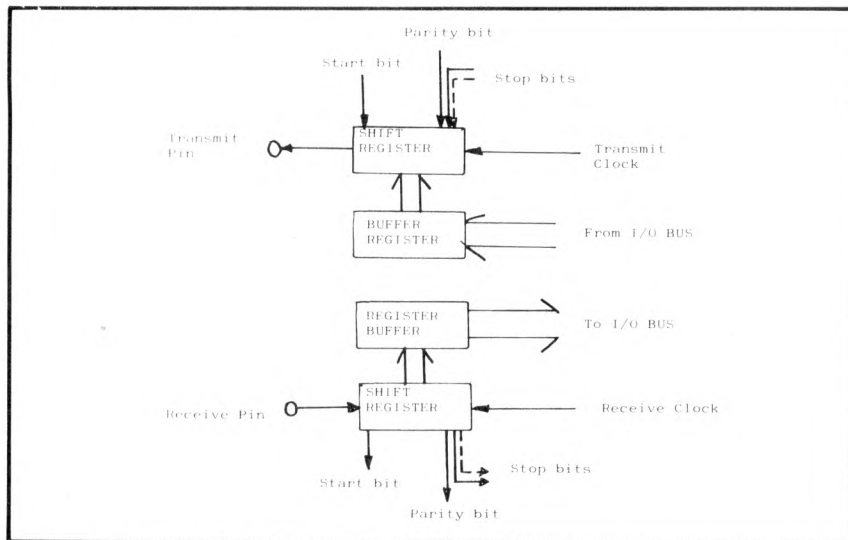

Fig. 2. Block Schematic of a Simple UART

usually implemented in hardware and the rest in software. This month I shall restrict myself to the hardware which usually takes the form of an 'add-on' PC Board which interfaces to the micro's I/O bus on one side and to one or more communications interfaces on the other. A single-line communications board is illustrated in Figure 1. Note that some Single-Board computers incorporate serial I/O capability as standard.

I admit to being old enough to remember the (pre-LSI) days when all the above functions were performed in software. Yes, that's right, you had to write programs which deserialized characters and stuffed the bits down the telephone line. Fortunately, that did not last too long and boards based upon TTL components soon became available. The big breakthrough came with the development of the Universal Asynchronous Receiver/Transmitter (UART). The UART was invented by any semiconductor company you care to ask.

Figure 2 shows how a UART chip does what we need.

Many of you will have already come across UARTs being used in cassette tape and printer interface boards. For the sake of completeness, I should tell you that there are now a whole family of UART-like devices from a variety of suppliers.

On the simpler ones, the facilities required (e.g. bit rate, odd/even parity, number of stop bits) are selected by the use of jumpers. More recent models are sometimes called (confusingly, in my opinion) 'programmable'! What it means is that the option can be specified via a parameter register, the values of which can be loaded from a program. The arrangement is easier to understand if it is described as having 'software selectable options'.

As the density of chips has increased the functions performed in the UART have increased accordingly. 'Super UARTs' are known as Universal Synchronous/Asynchronous Receiver/Transmitters (USARTs or just USRTs) and are capable of performing advanced checking functions (Cyclic Redundancy Checking), data link controls (more of which next time) and perform timing functions at both block and character levels. As few of these functions will be needed for our planned Personal Computer Network, we only

need to be concerned about the more simple UARTs.

For the homebrew enthusiast and those who like more detail: Figure 3 shows a more complete picture of a typical communications board. Not being famous for my hardware capabilities, I had my good friend Dr. Martin Healey, of University College Cardiff, draw up this schematic. The additional logic needed to support the UART is as follows:

- A: Raises 'Request-to-Send' on the V-Series interface and checks for 'Clear-to-Send' which indicates that the modem is sending a stable carrier and is ready for the data bits.
- B: The baud-rate generator receives a clocking signal from a crystal oscillator or from the I/O bus (e.g. 2 MHz on the S100). This is then subdivided to produce the required bit-rate (e.g. 110, 300, 600 or 1200 bit/s). Note that, with many UARTs, the transmit and receive rates may be different.
- C: The optional interrupt logic is used to tell the processor that the UART can receive the next character for transmission or that an input character has been received satisfactorily.
- D: The address select and interface logic looks after the inter-working with the processor.

So far, so good. Next time we shall look at data link control procedures.

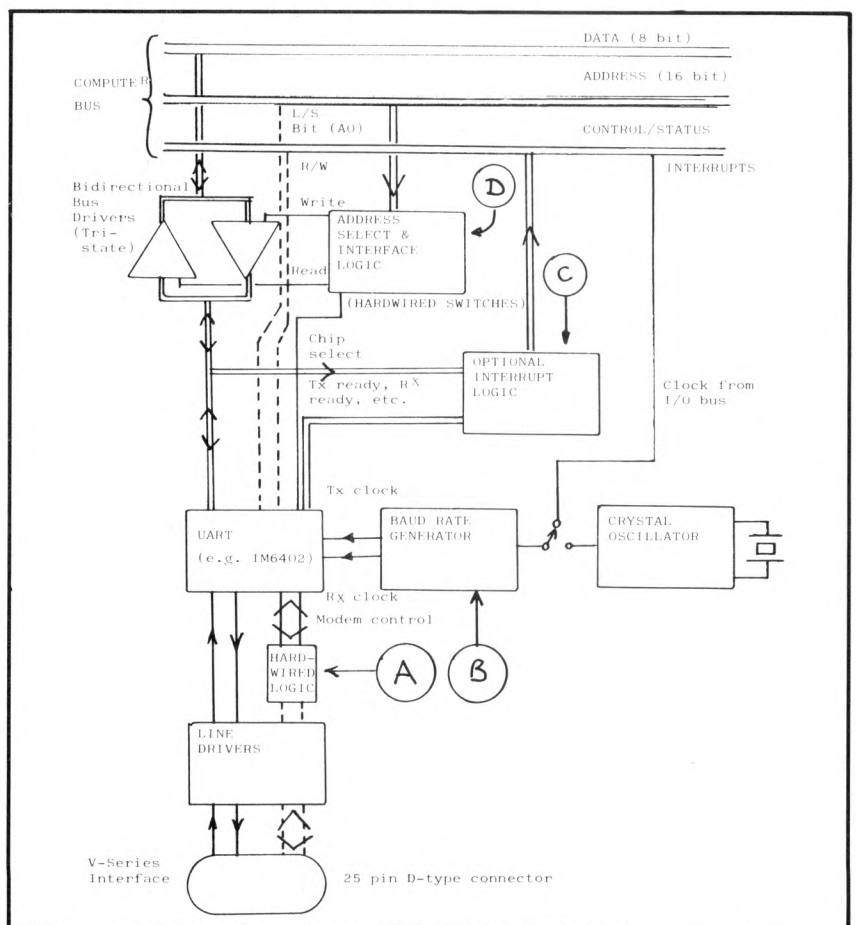

Fig. 3. General Schematic of a Communications Interface Board



# TRANSAM

## The exciting new TRITON Personal Computer

**TRITON** — A British designed home computer kit that can be expanded up to 64k memory on the motherboard shown.

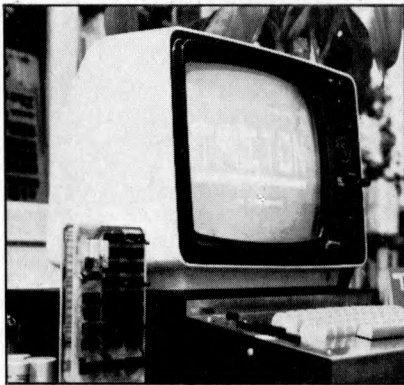

**Transam Components Ltd.,**  
12 Chapel Street, London NW1.  
Tel: 01-402 8137

**AVAILABLE NOW! NO WAITING!**

- 3 options in basic, including 7k scientific
- Up to 8k on main board, 56k off board
- 64 graphic characters
- Power supply and cabinet supplied with basic kit
- Fully encoded ASC keyboard
- Software printer interface with options 2 & 3
- Easy conversion from option 1 to 2 & 3 using EPROMS and our programming facility

**TRITON** — An easy-to-buy computer

- All components available separately or in packs to suit your budget
- 118 page manual with all you need to know
- TV or monitor display
- Modem tape I/O or communications interface

**FIRMWARE OPTIONS ON TRITON SYSTEM**

- option 1** L4.1 with 2k tiny basic & 1k monitor on main board **£286.00**
- option 2** L5.1 with 2.5k tiny basic & 1.5k monitor on main board **£294.00**
- option 3** L6.1 with 7k scientific basic & 1.5k monitor. Resides off board & price includes motherboard system plus EPROM card all buffered and 56k to go **£399.00**

Future options include floppy disc interface and controller.

**EXPANSION BOARDS** — available now!

- Motherboard kit with 6 amp power supply, buffering and 2 sockets **£50.00**
- 8k RAM card kit (using 2114's) **£97.00**
- EPROM card kit (with 2708's) **£97.00**  
(without 2708's) **£31.00**
- Motherboard case **£13.00**

All prices exclude VAT at 15% (currently), 118 page manuals + 10p p&p — Full details in Summer 1979 catalogue available at 40p.

## V. & T. ELECTRONICS

**CPU CONTROLLED CASSETTE DECK**

Connects to any 8 bit IO port & UART, full CPU control of fast forward, reverse, read and write, searches tape under software control for named files at up to 50 inches per second (Z80 software supplied) includes high speed CUTS interface — 2400 baud i.e. 1K bytes in 4.2 seconds. One C60 tape holds 860K bytes, ideal for NASCOM 1. Supplied ready built, not a kit, includes a.c. mains power supply. **£110 + 15% VAT**  
Postage & packing £2.00

Please call for demonstration

**FULLY Relocatable assembler for NASCOM 1** (easily converted to other systems) supports pseudo-ops + all Z80 opcodes, includes powerful text editor, uses approx. 3½K memory, all work areas programmable. Supplied on tape. **£10 + VAT**

- 2716 Eproms Intel Ex. Stock **1 off £23.50**
- 4116 16K Dynamics 200ns **8 off £56.00**
- 2114 4K Statics 200ns **2 off £10.00**
- Z80A **1 off £14.00**
- Z80 PIO **1 off £10.00**

**NEW!**  
TRS-80 16K upgrade **£57.00**

We are usually open 7 days a week until very late, please phone first before calling. **Please add 40p p&p.**

**82 CHESTER ROAD,  
LONDON N19  
01-263 2643**

## U NO THE ELF BUT DO YOU KNOW OUR PRICES?

- \*Basic Computer Kit **£79.95**  
or wired and tested **£99.95**
- Cabinet & Flexiglass cover **£22.00**
- \*Constructors/Users Manual **£ 4.00**
- 4K Static Memory Board **£63.00**  
or wired and tested **£83.00**
- ELF II Expansion Power Board **£15.00**
- ELF II Tiny Basic Generator **£12.00**
- \*R.F. Modulator **£ 3.00**
- Giant Board Kit **£32.00**
- Giant Board Kit wired and tested **£52.00**
- \*Power Supply Transformer **£ 5.00**
- \*Micro Processor/Computer Book **£ 4.00**
- Pro ASCII Keyboard Kit **£53.00**
- Pro ASCII wired and tested **£73.00**
- Pro ASCII Keyboard steel cabinet **£15.00**
- ELF Bug Monitor **£12.00**

**\*SUGGESTED MINIMUM INITIAL ORDER**

Please tick items required, add 15% VAT to total cost, enclose your cheque, print your name, address and telephone number below and post complete to **C.A.V.S. Ltd., 171 Chase Side, Enfield, Middlesex, EN2 0PH.**

Name ..... Tel. No. ....

Address .....

.....



Room PW  
313 Kingston Road, Ilford,  
Essex, IG1 1PJ, England  
01-553 1001

**A COMPREHENSIVE SELECTION OF MICROCOMPUTER BOOKS AND MAGAZINES FOR THE HOBBYIST, EDUCATIONALIST, PROFESSIONAL AND RETAILER.**

Introduction to Microcomputers:	
Vol 0: Beginners Book	<b>£5.95</b>
Vol 1: Basic Concepts	<b>£8.30</b>
Vol 2: Some Real Microprocessors (without binder)	<b>£18.95</b>
Vol 2: Some Real Microprocessors (with binder)	<b>£24.70</b>
Vol 3: Some Real Support Devices (without binder)	<b>£11.95</b>
Vol 3: Some Real Support Devices (with binder)	<b>£17.70</b>
Updating subscription (6 issues) for Vol 2	<b>£18.95</b>
Updating subscription (6 issues) for Vol 3	<b>£18.95</b>
Updating subscriptions for Vol 2 & 3	<b>£30.00</b>
1 Updating issue (specify for Vol 2 or 3)	<b>£4.00</b>
1 Binder (Specify for Vol 2 or 3)	<b>£5.75</b>

Microprocessors from Chips to Systems	<b>£7.95</b>
Microprocessor Interfacing Techniques	<b>£7.95</b>
Z80 Microcomputer Handbook	<b>£7.50</b>
TV Typewriter Cookbook	<b>£7.50</b>
T.T.L. Cookbook	<b>£7.50</b>
CMOS Cookbook	<b>£7.95</b>
IC OP-AMP Cookbook	<b>£9.50</b>
RTL Cookbook	<b>£4.25</b>
IC Timer Cookbook	<b>£7.50</b>
The Cheap Video Cookbook	<b>£4.30</b>

6800 Programming for Logic Design	<b>£6.30</b>
8080 Programming for Logic Design	<b>£6.30</b>
Z80 Programming for Logic Design	<b>£6.30</b>

Introduction to Personal and Business Computing	<b>£4.95</b>
Getting Involved with your Own Computer	<b>£4.75</b>
Your Home Computer	<b>£5.95</b>
How to Profit from Your Personal Computer	<b>£5.50</b>

Hobby Computers are Here	<b>£3.95</b>
New Hobby Computers	<b>£3.95</b>
Understanding Microcomputers and Small Computer Systems	<b>£6.50</b>

BASIC Computer Games	<b>£5.50</b>
What To Do After You Hit Return	<b>£8.95</b>
8080 Galaxy Game	<b>£6.95</b>
Computer Rage (A Board Game)	<b>£6.95</b>
Artist and Computer	<b>£3.95</b>
Games, Tricks & Puzzles for a Hand Calculator	<b>£2.49</b>

Instant BASIC	<b>£7.50</b>
Basic BASIC	<b>£6.50</b>
Advanced BASIC	<b>£6.00</b>
My Computer Likes Me . . . When I Speak in BASIC	<b>£2.75</b>
Introduction to PASCAL	<b>£3.95</b>

Accounts Payable and Accounts Receivable	<b>£10.95</b>
Payroll with Cost Accounting	<b>£10.95</b>
General Ledger	<b>£10.95</b>

Z80 Instruction Handbook	<b>£2.95</b>
8080 Programmers Pocket Guide	<b>£1.95</b>
8080 Hex Code Card	<b>£1.95</b>
8080 Octal Code Card	<b>£1.95</b>

Basic Software Library:	
Vol 1: Business and Games Programs	<b>£17.50</b>
Vol 2: Maths, Engineering and Statistical Programs	<b>£17.50</b>
Vol 3: Advanced Business Programs	<b>£26.95</b>
Vol 4: General Purpose Programs	<b>£7.95</b>
Vol 5: Experimenters Programs	<b>£7.95</b>
Vol 6: Miniature Business System	<b>£32.50</b>
Vol 7: Chess/Medbil/Wdproc Programs	<b>£26.95</b>

Dr Dobbs Journal Vol 1	<b>£10.00</b>
Best of BYTE	<b>£8.95</b>
Scelbi BYTE Primer	<b>£9.95</b>
Best of Creative Computing Vol 1	<b>£6.95</b>
Best of Creative Computing Vol 2	<b>£6.95</b>
Best of MICRO	<b>£5.50</b>

Some Common BASIC Programs	<b>£6.30</b>
Computer Programs that Work (in BASIC)	<b>£2.55</b>
First Book Of KIM	<b>£7.00</b>

8080A/8085 Assembly Language Programming	<b>£6.45</b>
6800 Assembly Language Programming	<b>£6.45</b>
8080 Software Gourmet Guide and Cookbook	<b>£6.95</b>
6800 Software Gourmet Guide and Cookbook	<b>£6.95</b>

8080 Standard Monitor	<b>£9.95</b>
8080 Standard Editor	<b>£9.95</b>
8080 Standard Assembler	<b>£9.95</b>
Special Package: 8080 Assembler, Editor, Monitor	<b>£20.00</b>
Bar Code Loader for 6800, 8080, Z80 and 6502	<b>£1.75</b>
Tiny Assembler for 6800 Systems	<b>£5.75</b>

<b>Magazine Subscriptions:</b>	<b>UK Price</b>	<b>Overseas Price</b>
Subscriptions start within 3 weeks		
MICRO-6502 Journal (12 issues)	<b>£10.50</b>	<b>£15.00</b>
Personal Computing (12 issues)	<b>£16.00</b>	<b>£17.00</b>
Interface Age (12 issues)	<b>£20.00</b>	<b>£21.00</b>
Dr Dobbs Journal (10 issues)	<b>£13.00</b>	<b>£13.50</b>
Computer Music Journal (4 issues)	<b>£10.50</b>	<b>£11.00</b>
People's Computers (6 issues)	<b>£8.00</b>	<b>£8.50</b>
BYTE (12 issues)	<b>£21.00</b>	<b>£21.00</b>
Creative Computing (12 issues)	<b>£16.00</b>	<b>£16.50</b>
Calculators and Computers (7 issues)	<b>£10.00</b>	<b>£10.50</b>
Kilobaud (12 issues)	<b>£20.00</b>	<b>£21.00</b>
73 (12 issues)	<b>£20.00</b>	<b>£21.00</b>

<b>Magazine Back Issues:</b>	
Micro-6502 Journal	<b>£1.50</b>
Personal Computing	<b>£1.75</b>
Interface Age	<b>£2.25</b>
ROM	<b>£1.75</b>
Dr Dobbs Journal	<b>£1.75</b>
Computer Music Journal	<b>£3.75</b>
People's Computers (recent issues called Recreational Computing)	<b>£1.75</b>
BYTE	<b>£2.25</b>
Creative Computing	<b>£1.75</b>
Calculators and Computers	<b>£1.75</b>
Kilobaud (reprints only)	<b>t.b.a.</b>
73	<b>£2.25</b>
Magazine Storage Box (Holds 12)	<b>£1.25</b>

THIS LIST CANCELS ALL PREVIOUS PRICE LISTS: EFFECTIVE APRIL 1979

DUE TO FLUCTUATIONS OF THE DOLLAR, PRICES SUBJECT TO CHANGE WITHOUT NOTICE.

**HOW TO ORDER**

Please note our prices include postage and packing, but not insurance, if wanted add 12p for every £10. of books ordered. Make cheques, PO's etc. payable to:-

**L.P. Enterprises.**  
CREDIT CARDS accepted  
BARCLAYCARD VISA / ACCESS  
DINERS CLUB / AMERICAN EXPRESS  
N.B. Diners Club orders cannot be accepted by telephone.  
Phone: 01-553 1001 for Credit Card orders (24-hr answering service)

Send to address above	All Orders must be Prepaid
Indicate Payment Method:	Total Enclosed £ . . . . .
. . . . . My cheque, P.O., I.M.O. is enclosed in Sterling on U.K. Bank	
. . . . . Charge to Barclaycard/Visa/Access/Diners/American Express	
Credit Card No . . . . .	Expiry Date . . . . .
Name . . . . .	
Address . . . . .	
. . . . .	POSTCODE . . . . .
Signature . . . . .	

All publications are published in U.S.A. and shipped air-freight by L.P. Enterprises. In unusual cases, processing may exceed 30 days. Prices subject to change without notice.

**TRADE ENQUIRIES WELCOME**

# D to A Converter

**John Coll**

*Oundle School, Peterborough*

A Digital to Analogue converter is used to produce signals to drive oscilloscopes or amplifiers and loudspeakers to draw pictures or play tunes. It can also be used in servo systems.

Signetics have produced a single I.C. micro-processor D to A converter which makes the whole process simplicity itself. It is quite a lot nicer than the Ferranti ZN425 since it includes a Latch enable input which greatly simplifies connection to the data bus. The part number is NE5018 and it is suitable for most micros.

I have designed a printed circuit board for the SWTPC system (since that machine was available) with 2 D to A converters on one board. This enables X Y plotting to be done on a 'scope screen — and music to be played in stereo I suppose! The circuit is shown below together with a reduced copy of the artwork used.

The final design gives out 0 to 10 volts with a settling time of about 2 micro-seconds.

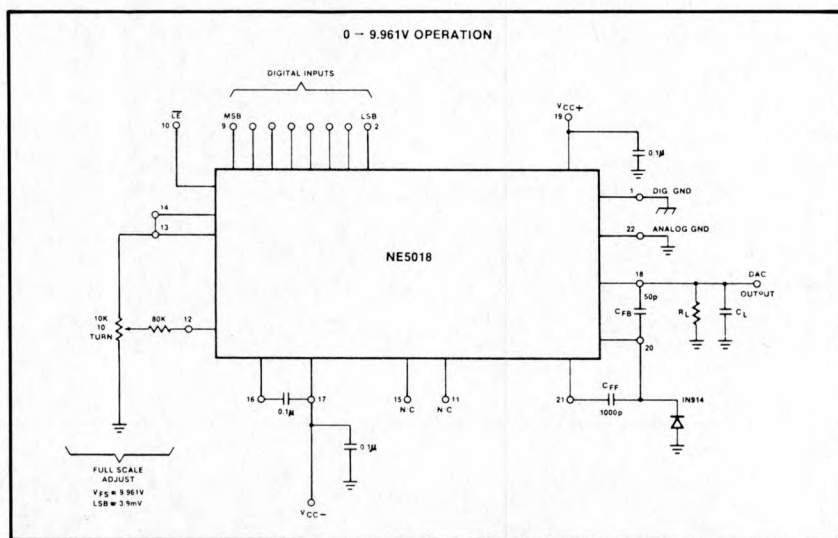
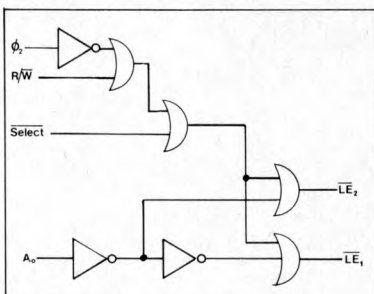

*The Signetics D/A Converter*

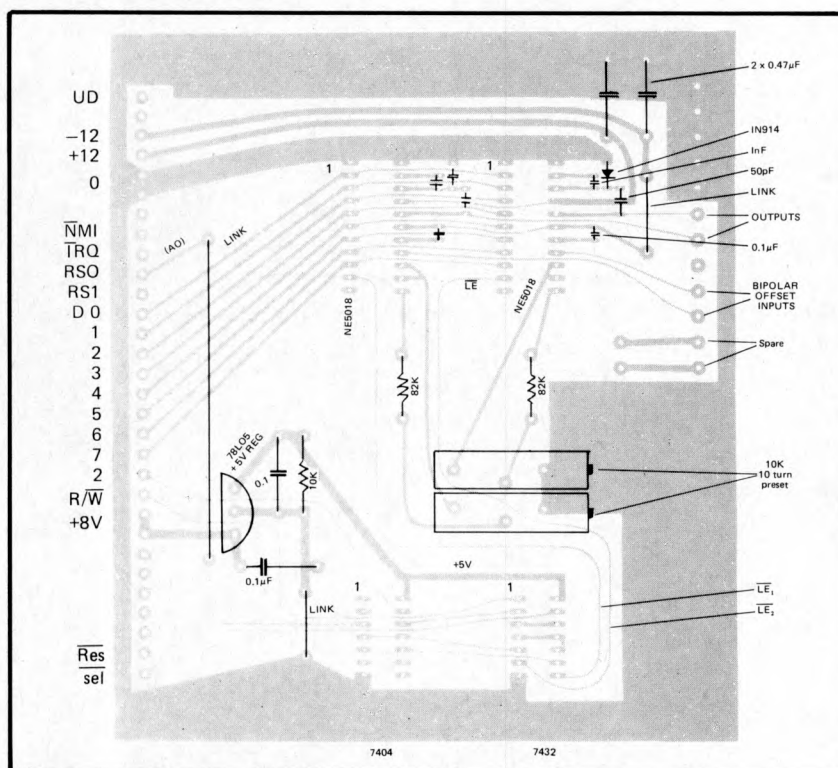

*Top View of PCB for SWTPC System*

# BRISTOL COMPUTER CENTRE

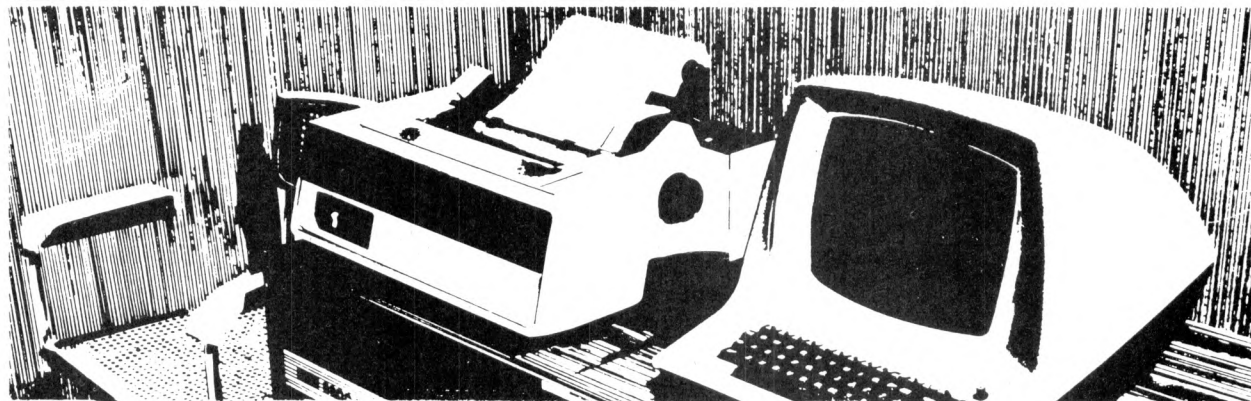

At the Bristol Computer Centre we have a complete range of professional micro-computer systems. Not kits or toys but fast, reliable systems that will get the job done . . . . without fuss.

We are the main agents in the South West for Modata, SWTP and Commodore. So we can supply just about any system, for any task – from a 4 k-byte PET to a 28 m-byte advanced Modata hard-disc

communicating system.

And all our systems have a choice of visual display units, printers and other peripherals plus full maintenance support.

Software packages including stock control, order-processing, word-processing, accounts, etc can give you instant control of your business.

Telephone now for a demonstration and see for yourself.

THE  
**BRISTOL  
COMPUTER  
CENTRE**  
MICRO HOUSE,  
ST. MICHAEL'S HILL,  
BRISTOL  
TEL: 0272 23430

## XITAN SYSTEMS

Southern England stockists for **CROMEMCO**

Selected nationwide by Government departments, Research Establishments, Universities, Professional Consultants, Assurance Companies, Industry and the serious hobbyist. Features include a range of software equalled by no other manufacturer for price and performance. Fortran, Basic, Cobol, Z-80 Macro Assembler, Trace, and Word Processing, all at only £85 each. Xitan Systems can supply CP/M for use on Cromemco equipment with 8 in. floppy discs.



*THE machine for professional use*

XITAN SYSTEMS, 23 CUMBERLAND PLACE, SOUTHAMPTON SO1 2BB. TEL: (0703) 38740

Also suppliers of: PET \* HORIZON \* PT SOL \* DYNABYTE MEMORY \* BOOKS \* VDUs \* PRINTERS

# Practising a little Micro-control

Mike Dennis

Much has been said on busses and the basic schematic layout of personal computers. However, little has been published on what the various *control signals* that come out of the CPU chip do, and how you can use them. To list them all would fill this magazine and so I intend to fill the gap with reference to the Z-80.

## The basic design

Figure 1 shows the familiar block diagram of a typical computer. In order to determine what control signals may be necessary, we must list those operations that are required from the computer. Table I shows them.

- |   |
|---|
| 1/ CPU sends data to memory             |
| 2/ CPU receives data from memory        |
| 3/ CPU sends data to I/O (Input/Output) |
| 4/ CPU receives data from I/O.          |

TABLE I

Larger computers like the PDP-11 have the added facility to move data to and from memory and I/O but in the micro world this is generally not the case and so transferring data from I/O into memory would require a combination of operation (4) then (1). Table I can be re-arranged thus:—

- |   |
|---|
| a/ The CPU communicates with either memory or I/O |
| b/ The CPU either sends or receives data.         |

TABLE II

The system needs to know *which one of these is to take place* and the control signals do precisely that. There are four control signals from the Z-80 and they are:—

- 1/  $\overline{\text{MREQ}}$  — indicates CPU wishes to communicate with memory and that the address bus is stable and valid. ('Memory REQuest.')
- 2/  $\overline{\text{IORQ}}$  — indicates CPU wishes to communicate with I/O and that the address bus is stable and valid. ('I/O ReQuest.')
- 3/  $\overline{\text{WR}}$  — WRite — CPU wishes to send data — the data bus is now stable and valid.
- 4/  $\overline{\text{RD}}$  — ReaD — CPU wishes to receive data

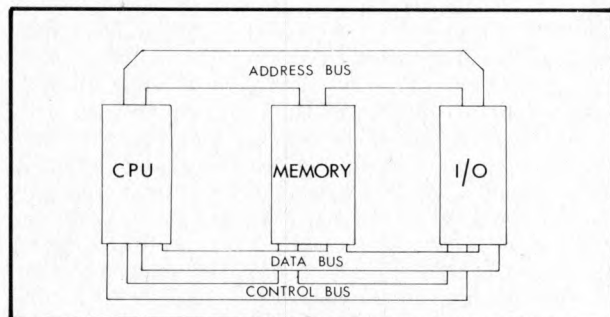

Figure 1.

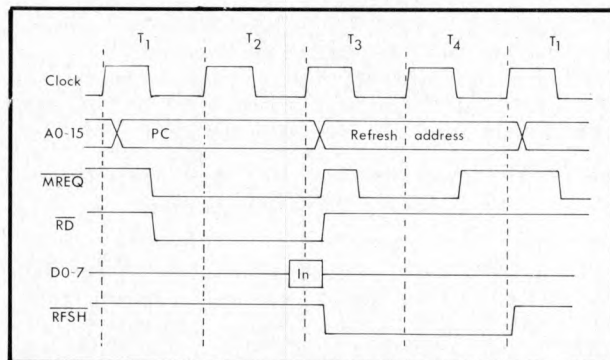

Figure 2.

These signals are all automatically generated by the CPU. Moreover, as far as the CPU is concerned, they are generated at the right time *with respect to each other*. It is up to the user to do something useful with them!

For example, when operation (2) is in progress, the CPU would make both  $\overline{\text{MREQ}}$  and RD active. The bar over the top means that they are 'active low', ie when they are active, they are at logic 0 or 0v or whatever you like to call it. Table III shows the logic state of the four control signals for each of the operations.

(Table I operations)				
	MREQ	IORQ	RD	WR
(1)	0	1	1	0
(2)	0	1	0	1
(3)	1	0	1	0
(4)	1	0	0	1

TABLE III

Some computer manufacturers, eg Tandy, gate these controls together and derive four different ones:—MEMRD and MEMWR (memory read and write) and IORD and IOWR. Personally, I think this is a waste of time as one can lose the flexibility of the four original signals.

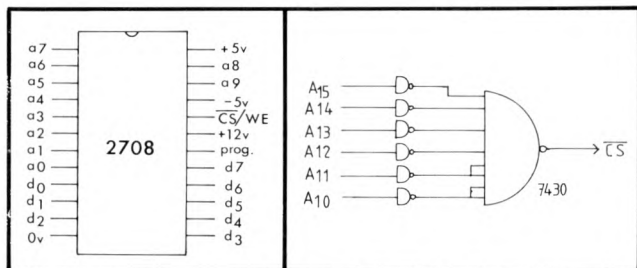

Figure 4.

**How are the control signals used?**

The basic concept of the tri-state bus is that there is only one device on the bus at any one time that is supplying any data — the talker. All the other devices are sitting across the bus and listening. The control signals help discriminate between the talker and the listeners and allow them to talk or listen at the correct time.

After reset is hit, all the internal registers are cleared and the program counter is forced to a specific value or address, depending on which CPU chip is used. The contents of the program counter are then transferred to the address bus as an address and, in the case of the Z-80, this address is 0000. The Z-80, therefore, expects to find the first program instruction at this address.\* This instruction will reside in memory, the CPU wants to read it and so MREQ and RD will be made active (in this case, active low) by the CPU — see Figure 2, which has been taken from the Z-80 Technical manual. Notice that the whole operation takes four clock cycles.

The next step is to apply the controls to memory in such a way that the data at address 0000 finds its way onto the data bus so that the CPU can read it.

**How Memory Uses Control Signals**

Figure 3 shows the pin connections for a 2708 EPROM. This device has a capacity of 1k bytes (2<sup>10</sup> bytes) and so 10 pins are needed to access all the memory locations within the chip. The data is output onto the data bus via pins 9-11, 13-17 inclusive, AND only when pin 20 (CS; CS = Chip Select) has been taken low otherwise the o/p/s (outputs) of the 2708 are tri-stated. The CPU has put out 0000H or 0000 0000 0000 0000 onto the address bus but the 2708 is only interested in the logic state of the ten lower bits of the bus (A<sub>0</sub> to A<sub>9</sub>). The remaining six bits can be used to uniquely define the 2708's position in the possible 64k bytes of memory that the micro could address. There are two methods of decoding and they are:—

\*There are hardware tricks that fool the rest of the computer into thinking that a different address is present on the bus. I do not intend to go into them now.

**1/ Full decoding**

Here the remaining six bits are combined via a logic circuit that will only give an output when a certain bit pattern is present. The 2708 must respond to a base address of 0000 and so the circuit of Figure 4 will decode this. The output from the decoder is 0 which, conveniently, is needed by CS in order to enable the 2708.

**2/ Partial decoding**

This is only suitable for a system of limited size and one that is not going to expand. Assuming that it consists of, say, 4k bytes of RAM and 2k bytes of ROM, then each of the spare six address lines could be used directly as the Chip Select (CS) for each k byte of memory. Figure 5 shows how they could all be used and the various base addresses that they will each respond to. Notice that address 0000 still needs to be completely decoded and this has not been shown. Care must be taken when programming to prevent any attempt at reading or writing to addresses that would select two or more blocks of memory. For example, an instruction to read data at address F000 would be disastrous as all four blocks (A, B, C & D) would be selected simultaneously!

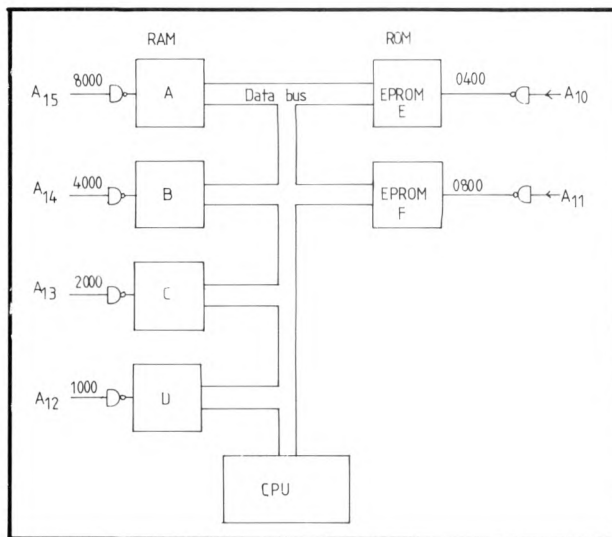

Figure 5.

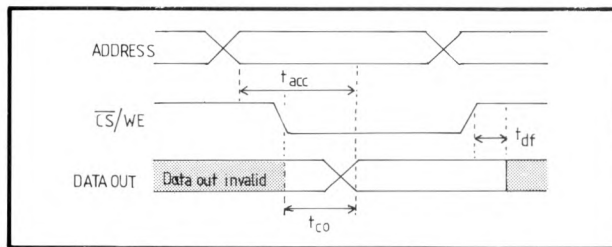

Figure 6.

Full decoding is certainly well worth while and always pays dividends in the end as bus conflicts are avoided. You perhaps are wondering about RD and WR? Well . . .

All memory has an inherent delay between the address being presented at the memory chip's pins and then valid data appearing on the output pins. There will almost certainly be rubbish on the pins until a certain time has passed — the access time. Access time is often quoted as part of the chip number, eg —2102-4 (450ns) access time. It can also be found from data sheets, and Figure 6 shows that for the 2708 while Table IV gives the timings.

Symbol	Parameter	Min	Typical	Max	Unit
t <sub>acc</sub>	Address to o/p valid		280	450	nS
t <sub>co</sub>	Chip select to o/p valid		60	120	nS
t <sub>df</sub>	Chip select to o/p tri-stated			120	nS

TABLE IV

We are told that the data will be valid at a maximum time of 450 nSecs after the address has been presented and CS has been low for at least 120 nSecs. Relate Figure 6 to Figure 2. If we are using a clock frequency of 2MHz then one clock cycle will take 0.5uS or 500nSecs. The CPU samples data on the rising edge of T3 and so our data must be valid and stable on the data bus by this time.

Have we enough time? The address is present on the 2708 for nearly all of T2 and most of T1 before the critical edge of T3 occurs. That is nearly 1000 nSecs and more than enough for our 2708. We can use Figure 4 to chip select the 2708 and further combine this signal with MREQ and RD to enable a separate chip that buffers the outputs of the 2708 from the data bus. This is shown in Figure 7.

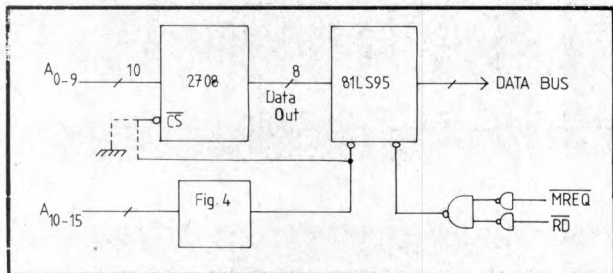

Figure 7.

In fact, with Figure 7, there is no reason why CS of the 2708 shouldn't be permanently tied low provided that the tri-state buffer is only enabled when A<sub>10</sub> - A<sub>15</sub> are low and MREQ and RD are active - shown dotted. A similar process can be applied to RAM and this is discussed next.

Read and write

RAM really is an awful word! We don't actually random access the memory; if we did, there's no telling what data would come out. What is done is Read/Write but no-one seems to call it that. Figure 8 shows the timing diagram for a Memory Write by the Z80; Figure 9 - the timing diagram for a 2102 RAM; and table V gives the timings.

Symbol	Parameter	Min. Time (nSec)
t <sub>wc</sub>	Write cycle	450
t <sub>aw</sub>	Address to write set-up	20
t <sub>wp</sub>	Write pulse width	300
t <sub>dw</sub>	Data setup	300
t <sub>cw</sub>	Chip enable (select) to write setup	300
t <sub>dh</sub>	Data hold time	

TABLE V

A brief explanation of some of the above follows now:-

- t<sub>aw</sub> - the address must be valid for at least 20nSec before write goes low.
- t<sub>dw</sub> - the data must be valid 300nSec before the write pulse goes high and moreover:-
- t<sub>dh</sub> - data must remain valid for 0nSec after write goes high.

Comparison between Figure 8 and 9 shows that the timings of the control signals from the Z80 are capable of providing the times shown in Table V. There is a fair margin as well. For example, data remains valid for some time (almost 200nSecs) after write goes high and so there is plenty of room for a chip that has a longer t<sub>dh</sub>. Figure 10 shows how a 2102 could be connected up to a buffer and address decoder. Work out what base address it will respond to - answer given at the end\*.

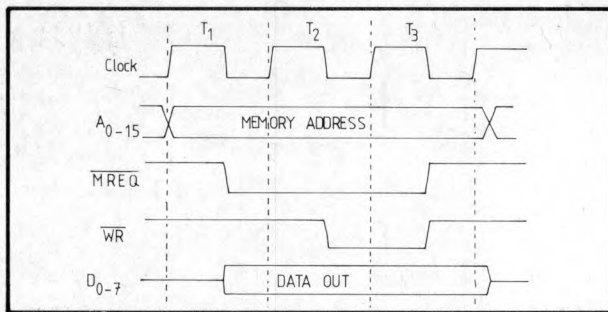

Figure 8.

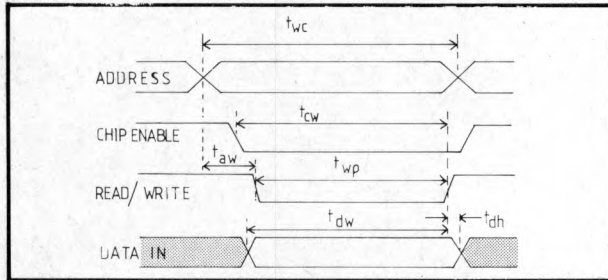

Figure 9.

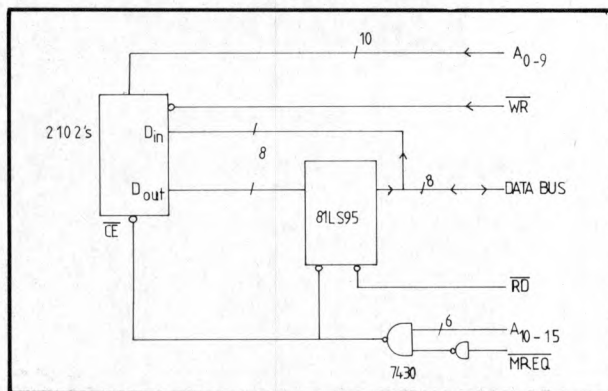

Figure 10.

What about I/O?

So far, we have only considered memory. I/O is very similar but this time, as mentioned previously, IORQ is used and not MREQ. RD and WR still perform the same functions. However, only the bottom eight address lines are used to decode which port is being accessed. Eight lines allow 256 different ports to be decoded and RD or WR will tell them which direction the data is going. Sometimes, several ports exist within the one chip (eg PIO's which have two data ports, two command or status ports at least) and the chip performs the decoding for itself for these ports. Timing is not a problem if you use peripheral chips from the same stable like the Zilog PIO or CTC. With other I/O devices, timing may or may not be a problem. It all depends on the speed with which the CPU transfers data to and from the device. Those devices that transfer data slowly, like UARTS, are easy, whereas those that transfer data quickly, like CRT or floppy disc controllers, are more difficult. You have to get the data sheets, burn the midnight oil and try it for yourself.

That completes this quick look on control signals but one further point remains regarding convention. When the CPU chip is reading data from either memory or I/O, then that device is writing to the CPU, so should the RD or WR line go active? Convention states that it is the action of the CPU that dictates which line goes active and, in this case, it will be the RD line - common sense really, since it's the CPU that generates the control signals and it should know what it's doing!

\*(Ans: FC00)

## THE RESEARCH MACHINES 380Z COMPUTER SYSTEM

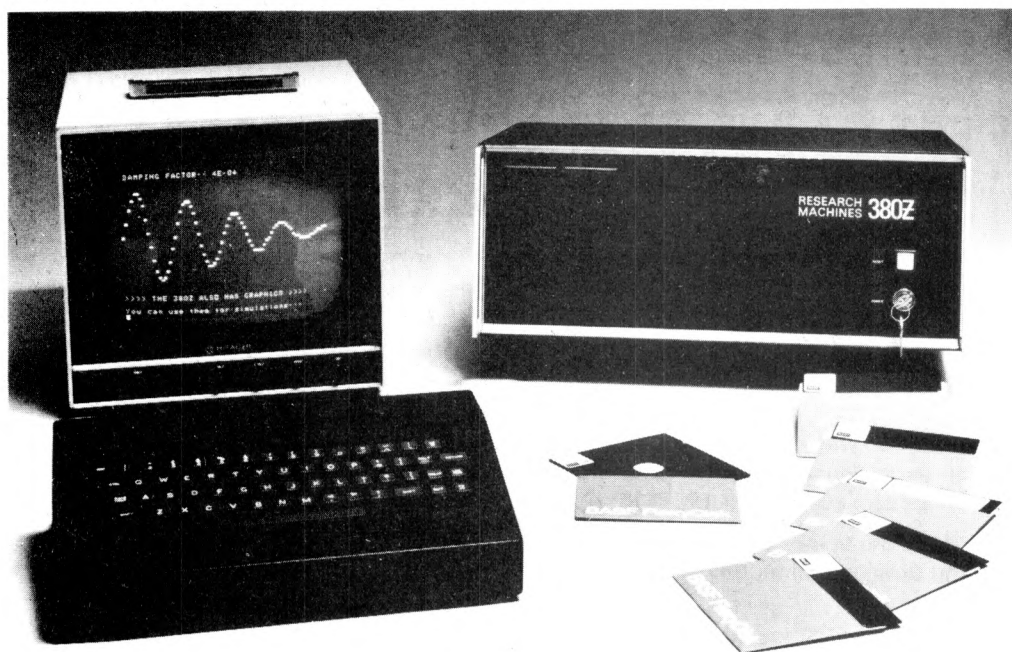

### THE RESEARCH MACHINES 380Z A UNIQUE TOOL FOR RESEARCH AND EDUCATION

Microcomputers are extremely good value. The outright purchase price of a 380Z installation with dual mini floppy disk drives, digital I/O and a real-time clock, is about the same as the annual maintenance cost of a typical laboratory minicomputer. It is worth thinking about!

The **RESEARCH MACHINES 380Z** is an excellent microcomputer for on-line data logging and control. In university departments in general, it is also a very attractive alternative to a central mainframe. Having your own 380Z means an end to fighting the central operating system, immediate feedback of program bugs, no more queuing and a virtually unlimited computing budget. You can program in interactive BASIC or, using our unique Text Editor, run very large programs with a 380Z FORTRAN Compiler. If you already have a mini-computer, you can use your 380Z with a floppy disk system for data capture.

What about Schools and Colleges? You can purchase a 380Z for your Computer Science or Computer Studies department at about the same cost as a terminal. A 380Z has a performance equal to many minicomputers and is ideal for teaching BASIC and Cesium. For A Level machine language instruction, the 380Z has the best software front panel of any computer. This enables a teacher to single-step through programs and observe the effects on registers and memory, using a single keystroke.

#### WHAT OTHER FEATURES SET THE 380Z APART?

The 380Z with its professional keyboard is a robust, hardwearing piece of equipment that will endure continual handling for years. It has an integral VDU interface — you only have to plug a black and white television into the system in order to provide a display

**380Z/56K complete with DUAL FULL  
FLOPPY DISK SYSTEM FDS-2**

**£3266.00**

RESEARCH MACHINES Computer Systems are distributed by RESEARCH MACHINES LTD., P.O. Box 75, Chapel Street, Oxford. Telephone: OXFORD (0865) 49792. Please send for the 380Z Information Leaflet. Prices do not include Carriage or VAT @ 15%.

unit — you do not need to buy a separate terminal. The integral VDU interface gives you upper and *lower* case characters and low resolution graphics. Text and graphics can be mixed *anywhere* on the screen. The 380Z has an integral cassette interface, software and hardware, which uses *named* cassette files for both program and data storage. This means that it is easy to store more than one program per cassette.

Owners of a 380Z microcomputer can upgrade their system to include floppy (standard or mini) disk storage and take full advantage of a unique occurrence in the history of computing — the CP/M™\* industry standard disk operating system. The 380Z uses an 8080 family microprocessor — the Z80 — and this has enabled us to use CP/M. This means that the 380Z user has access to a growing body of CP/M based software, supplied from many independent sources.

380Z mini floppy disk systems are available with the drives mounted in the computer case itself, presenting a compact and tidy installation. The FDS-2 standard floppy disk system uses double-sided disk drives, providing 1 Megabyte of on-line storage.

\*Trademark, Digital Research.

Versions of BASIC are available with the 380Z which automatically provide controlled cassette data files, allow programs to be loaded from paper tape, mark sense card readers or from a mainframe. A disk BASIC is also available with serial and random access to disk files. Most BASICs are available in erasable ROM which will allow for periodic updating.

If you already have a teletype, the 380Z can use this for hard copy or for paper tape input. Alternatively, you can purchase a low cost 380Z compatible printer for under £300, or choose from a range of higher performance printers.

**380Z/16K System with Keyboard**

**£965.00**



# O.K. so you've got a computer.

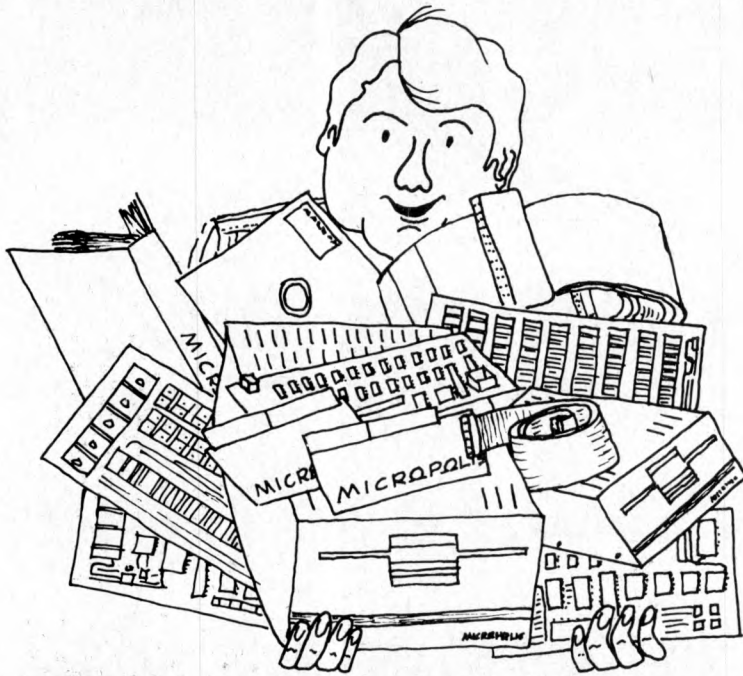

## So we've got all the add-ons!

### Floppy Disks

Micropolis drives are available in 143K and 315K (formatted) versions expandable from one to four drives in various packaging options. Prices quoted below are for single 143K units including 240V power supply and case.

**For S100 computers:** Cromemco, Vector, Horizon, SOL, Sourcerer with S100 expansion.

1042-1 Master unit; includes controller card and Micropolis system software	<b>£499</b>	1022-1 Add-on unit	<b>£339</b>
CP/M	<b>£100</b>	COBOL	<b>£400</b>

**For NASCOM and other small Z80 configurations:**

143BZ Master unit; includes controller card and Raindos system firmware	<b>£499</b>	1022-1 Add-on unit	<b>£339</b>
---	-------------	--------------------	-------------

**For Motorola D1 / D2, SWTPC MP-68 and other small 6800 configurations:**

143BM Master unit; includes controller card and RPDOS system firmware	<b>£499</b>	1022-1 Add-on unit	<b>£339</b>
---	-------------	--------------------	-------------

**For TANDY TRS 80 with expansion interface:**

1027 (T) Drive 1, 2, 3 or 4	<b>£339</b>
-----------------------------	-------------

### Memories

**For S100 computers:**

Vector 8K Static	<b>£150</b>
Vector 16K Static with bank switching	<b>£300</b>
Vector 48K Dynamic, Z80 refresh	<b>£500</b>

**For SS50 (SWTPC, MSI) computers:**

4K Static	<b>£ 80</b>
8K Static	<b>£140</b>
32K Dynamic, Onboard refresh	<b>£495</b>

### Microspeech

**For SS50 (SWTPC, MSI) computers:**

Microspeech analogue speech synthesiser converts text strings in phonetic spelling to audio output. Complete with special BASIC interpreter

**£295**



SINTROM GROUP

All prices exclude VAT and carriage  
 Dealer enquiries welcome  
 Please send for complete shortform  
 catalogue  
 Please enquire for add-ons to computers  
 not mentioned above

## Sintrom Microshop

14, Arkwright Road,  
 Reading Berks, RG2 0LS.  
 Telephone Reading (0734) 85464

# VISIONLINK

## MORE VDU BITS

### Interfacing & Software for Superscamp's VDU

W.G. Marshall

The first article (Jan '79) on Superscamp's VDU outlined the basic hardware module, without showing in detail how the computer (in my case SC/MP based) controls the appearance of characters on the screen. The suggested hardware and software interfacing will now be described, together with the optional 'extras' of hardware screen clear and keyboard repeat. The advantages of using memory-mapped RAM should become apparent, as any amount of cursor control is possible — with a large enough program! The subroutine listed in this article however, is limited to four main functions: *display character*, *carriage return*, *line feed with scroll* and *backspace cursor*. As a result the storage requirement for keyboard and VDU handler is less than 200 bytes. The backspace cursor function is included so that the subroutine may be used in place of the teletype routines on the end of the NIBL BASIC.

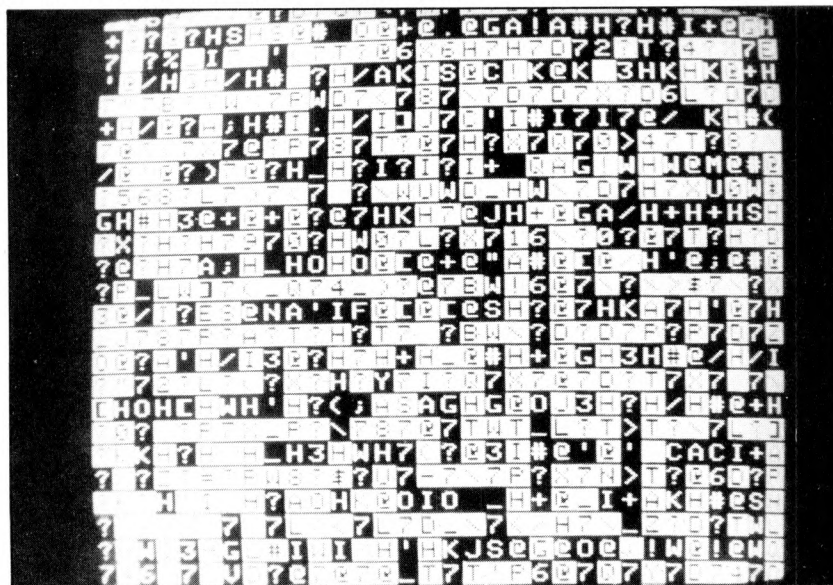

Random Display when power first applied.

#### VDU Interface & Screen Clear

The first control signal that we need to generate is  $\overline{VSEL}$ , the VDU select. The simplest way of doing this is to use one of the upper address lines (A10 — A15) suitably inverted, but this results in inefficient use of storage space as it means that a number of addresses will access the VDU. If we decode the top four address lines (A12 — A15) with a 4—16 line decoder, sixteen 4k page select signals are produced. Now decode the next two lines (A10 — A11) with a 2-4 line decoder to yield four 1k block select signals. If a page select and a block select are 'anded' together, every 1k block within the 65k range can be addressed uniquely. One of these 'anded' signals become our  $\overline{VSEL}$ . (Fig. 1.)

The 1k VDU RAM can now be placed anywhere in 65k.

The next signal to consider is RW, which is easily derived from the MPU write data strobe (NWDS in the case of SC/MP). Simply route NWDS through one of the spare multiplexers of X17, in such a way that it is only allowed to influence the RAMs while  $\overline{VSEL}$  is low. i.e. during computer access.

The tri-state enable  $\overline{TSE}$  is obtained by inverting NWDS and send-

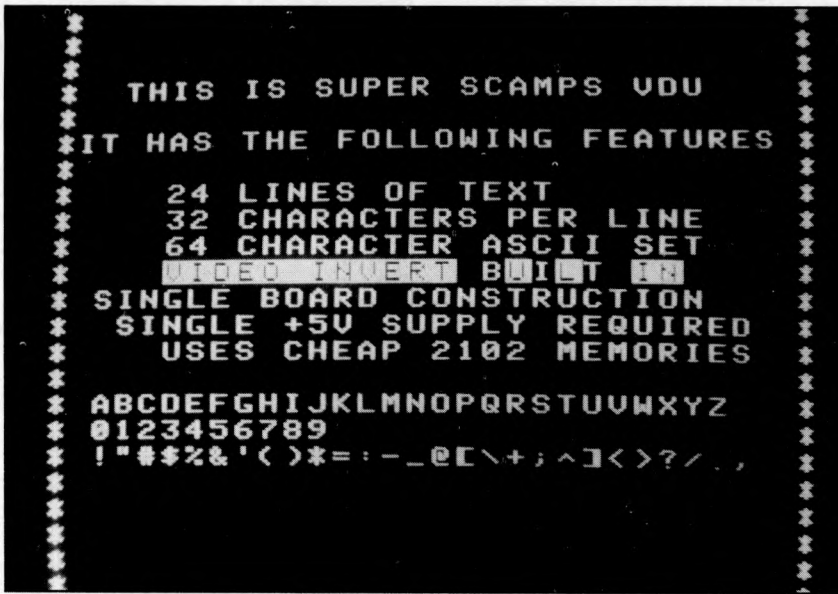

A Typical Display

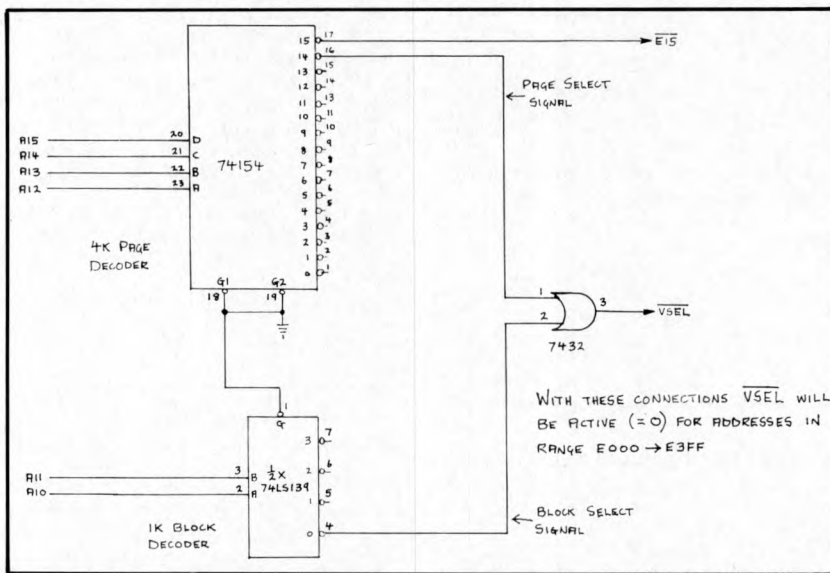

Fig. 1. Address Bus Decode

ing it through a second spare multiplexer in X17 (Fig. 2.) In a similar way to RW, TSE can only switch on the output buffers during a read computer access when VSEL is low.

With the data bus SDO-SD7, the address bus A0-A9, VSEL and NWDS, the computer now has complete control of the VDU RAM, so now let's move on to the manual control, SCREEN CLEAR. Why is this required? The answer lies in the second paragraph of the first article showing the display when the VDU is switched on. All we see is the random data set up in the RAMs. For a blank screen, every RAM location must contain the ASCII code for a space, 20 in hex.

The rest of the hardware in fig. 2 is designed to force this code into every location when the front panel push button SCREEN CLEAR is pressed momentarily. When the clear button is pressed, CLR goes low taking RW low all the while VSEL is high. In this way we can force data into the RAMs without computer access. This data will be the space code as CLR also switches over the data-in multiplexers X30 and X32 from the system data bus SDO-SD7, to a fixed code 20.

Note the two inverters X16a,b. These merely form a delay so that when the button is released, the write strobe is switched off the RAMs before the data-in multiplexers switch back. The button is de-bounced by latch X16c,d. While the button is pressed, ASCII space is written into every RAM location as the video address counters cycle through all possible addresses, thus 'clearing' the screen.

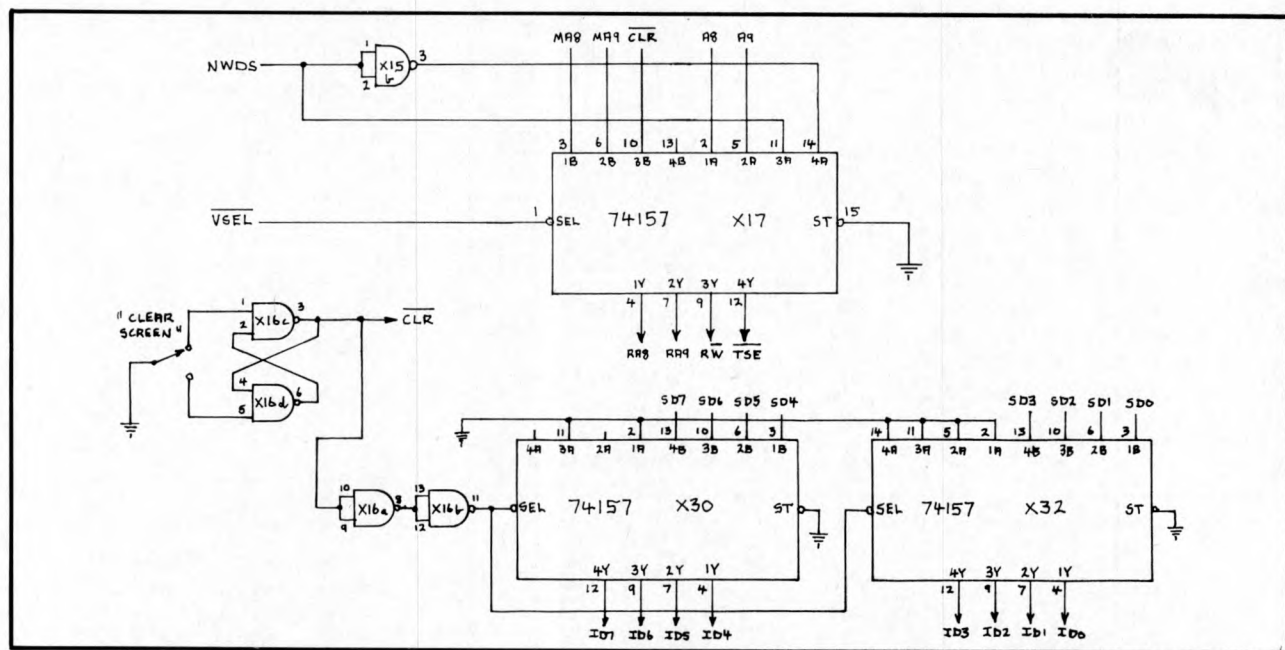

Fig. 2. VDU Control

**Keyboard Interface**

The keyboard is treated as a peripheral independent of the VDU, and the MPU addresses it as a single read-only memory location. The KB6, in common with most keyboards available, has seven data output lines (eight if parity is used), and a data ready strobe, making interfacing simple.

Two approaches are possible: the first is to connect the strobe to a non-maskable interrupt on the MPU, the second to latch the strobe and have the processor examine the latch periodically to see if a key has been pressed. The interrupt method is not very convenient on a SC/MP system, as the MPU only has a single interrupt arrangement requiring a pointer register to be reserved for the handler.

I chose to implement a latched set-up using one of SC/MP's sense inputs — SENSE B. The latter is tested by program when required, to 'sense' a key application. Refer to the hardware diagram Fig. 3. Having sensed the keystroke, the program addresses the keyboard data buffers X33, X34 and switches them on by taking  $\overline{KSEL}$  low, at the same time clearing the strobe latch X35a. The REPEAT button merely prevents the latter event from happening, so that the program keeps reading the same data over and over.

**Peripheral Decode**

How do we produce  $\overline{KSEL}$ ? The same method used for  $\overline{VSEL}$  is possible, but why waste a whole 1k select for one unique address? This would be reasonable for just one peripheral, but what if we need a dozen or more? In order to overcome these problems, let's do some more decoding of the address bus. I propose that the top 4k page of store, addresses FXXX, be reserved for peripherals. The top output, E15, of the page decoder (Fig. 1.) enables the G inputs of the peripheral decoder (Fig. 4.) which in turn decodes the bottom four address bits A0-A3 to one of sixteen peripheral select signals. Any one of the latter can be our  $\overline{KSEL}$ , and in my own case the allocation is as follows:—

PS0 — Panel display & data switches	— Address FXX0
PS1 — Paper tape reader	— Address FXX1
PS2 — Keyboard (KSEL)	— Address FXX2
PS3 — UART status (cassette & teletype)	— Address FXX3
PS4 — UART data (cassette & teletype)	— Address FXX4
PS5 — Paper tape punch	— Address FXX5
N.B. X = I don't care	

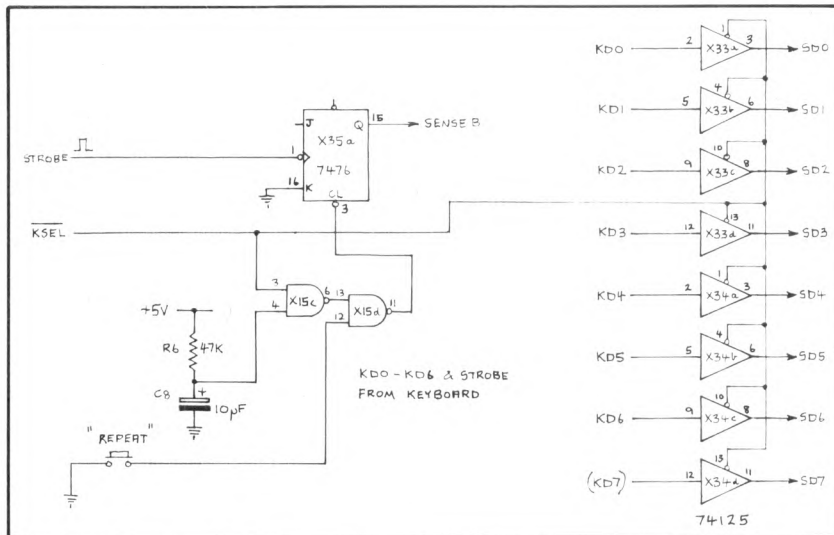

Fig. 3. Keyboard Control

Some storage space capability is still lost, but a big advantage lies in simplified programming for the SC/MP. If a pointer register in SC/MP, say P1, is set to F000 in hex, then instructions accessing the peripherals (VDU apart) can select between devices using the displacement byte of the instruction thus:—

```
LD 0 (P1) Loads accumulator from panel switches
XOR 2 (P1) Exclusive-ORs keyboard data with accumulator.
ST 4 (P1) Dump accumulator to UART.
```

**Software — The VDU & Keyboard Subroutine**

Included with this article is a keyboard and VDU control subroutine for a SC/MP based system, using the addressing techniques discussed. It is relocatable apart from the CRSR variable, but the latter can be placed in any convenient location. The following features should be noted:—

1. The cursor position is indicated by inverted video, and never moves off the bottom line of the 24 line display.
2. Carriage return code (OD) moves the cursor to the leftmost character position.
3. Line feed code (OA) causes the display to scroll up one line leaving the bottom line blank except for the cursor.
4. Backspace code (CTRL H = 08) moves the cursor back one character position.
5. All other control codes are ignored by VDU control section.
6. A normal character appears at the current cursor position, and then the cursor is advanced one character to the right.

7. Entry into the subroutine at KBD causes the MPU to wait for a keyboard entry, which is then echoed by the VDU section. The subroutine returns with the input character in the extension register.

8. Entry into the subroutine at VDU displays the character in the accumulator.

9. The VDU RAM in my case lies in the address range D000-D3FF, although only addresses D100-D3FF (= 24 lines) are visible on my monitor.

10. On entry at either point, P2 is assumed to be push-down stack pointer, pointing to the last stack entry. P1 contents are not preserved.

11. The main program must include setting CRSR to E0 in hex, amongst its initialisation routines.

**Conclusion**

The addressing techniques shown here are also applicable to other types of MPU systems, and should help the owner of an evaluation kit to expand the usually limited store provided. When used as main store decode, the 'anded' 4k, 1k select signals drive the  $\overline{CS}$  inputs of each 1k block of 2102s.

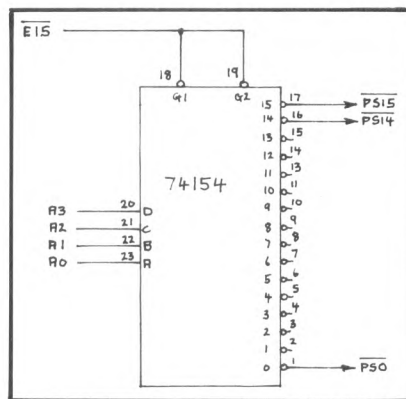

Fig. 4. Peripheral Decode

**Sources of Information**

1. THE TTL DATA BOOK (Texas Instruments)
2. SC/MP PROGRAMMING AND ASSEMBLER MANUAL National Semiconductor

# VISIONLINK

TITLE, VDU / SUPERSAMP VDU SUBROUTINES'

; P2 = PUSH-DOWN STACK POINTER.

; KEYBOARD SECTION.  
; MSB OF KEYBOARD DATA = 1

```

E000 C8 NOP
E001 C4 F0 KBD: LD H(PER)
E003 35 XPAH 1
E004 C4 00 LD L(PER)
E006 31 XPAL 1
E007 06 KEY: CSA
E008 D4 20 ANI X'20 ; KEY PRESSED?
E00A 98 FB JZ KEY
E00C C1 02 LD 2(C1) ; LOAD KEYBOARD DATA

; VDU SECTION
E00E 01 VDU: XAE
E00F C4 20 LD L(CRSR)
E011 31 XPAL 1
E012 C4 D0 LD H(CRSR)
E014 35 XPAH 1
E015 C1 00 LD 0(C1) ; LOAD CURSOR POINTER
E017 33 XPAL 3
E018 CE FF ST -1(C2) ; PUSH LP3
E01A C4 D3 LD H(CURPOS)
E01C 37 XPAH 3
E01D CE FF ST -1(C2) ; PUSH HP3
E01F 40 LDE
E020 D4 7F ANI X'7F ; REMOVE PARITY
E022 E4 08 XRI X'08
E024 98 34 BS ; BACKSPACE CODE?
E026 E4 02 XRI X'02 ; LINE FEED CODE?
E028 98 55 JZ LF
E02A E4 07 XRI X'07 ; CARRIAGE RETURN CODE?
E02C 98 1A JZ CR
E02E 40 LDE
E02F D4 60 ANI X'60
E031 98 39 JZ RET ; IGNORE OTHER CONTROL CODES
E033 40 VDU1: LDE
E034 D4 3F ANI X'3F
E036 CF 01 ST 0+1(C3) ; DISPLAY CHARACTER
E038 33 XPAL 3
E039 9C 04 JNZ NEXT ; CURSOR AT END OF LINE?
E03B 33 XPAL 3
E03C C7 FF LD 0-1(C3) ; BACK UP CURSOR
E03E 33 XPAL 3
E03F 33 NEXT: XPAL 3
E040 C3 00 LD 0(C3)
E042 DC 40 ORI X'40
E044 C8 00 ST 0(C3) ; RESET CURSOR
E046 90 24 JMP RET

; CARRIAGE RETURN ROUTINE
E048 C3 00 CR: LD 0(C3)
E04A D4 3F ANI X'3F
E04C C8 00 ST 0(C3)
E04E 33 XPAL 3
E04F D4 E0 ANI X'E0
E051 33 XPAL 3
    
```

```

E052 C3 00 LD 0(C3)
E054 DC 40 ORI X'40
E056 C8 00 ST 0(C3) ; RESET CURSOR
E058 90 12 JMP RET

; BACKSPACE ROUTINE
E05A C1 00 BS: LD 0(C1)
E05C E4 E0 XRI X'E0
E05E 98 0C JZ RET ; CURSOR AT FRONT OF LINE?
E060 C3 00 LD 0(C3)
E062 D4 3F ANI X'3F
E064 C8 00 ST 0(C3)
E066 C7 FF LD 0-1(C3)
E068 DC 40 ORI X'40
E06A C8 00 ST 0(C3)

; RETURN TO PROGRAM ROUTINE
E06C C6 01 RET: LD 0+1(C2) ; POP HP3
E06E 37 XPAH 3
E06F C6 01 LD 0+1(C2) ; POP LP3
E071 33 XPAL 3
E072 C9 00 ST 0(C1) ; STORE CURSOR POINTER
E074 40 LDE
E075 D4 80 ANI X'80
E077 98 03 JZ VDUA ; ENTRY AT KBD OR VDU?
E079 3F XPPC 3
E07A 90 85 JMP KBD
E07C 3F VDUA: XPPC 3
E07D 90 8F JMP VDU

; LINE FEED AND SCROLL ROUTINE
E07F C3 00 LF: LD 0(C3)
E081 D4 3F ANI X'3F
E083 C8 00 ST 0(C3)
E085 C4 D1 LDJ X'D1
E087 37 XPAH 3
E088 C4 20 LDJ X'20
E08A 33 XPAL 3
E08B CE FF ST 0-1(C2) ; PUSH LP3
E08D C7 01 ROLL: LD 0+1(C3)
E08F C8 DF ST -3(C3)
E091 33 XPAL 3
E092 9C 08 JNZ LOOP
E094 37 XPAH 3
E095 E4 D4 XRI X'D4
E097 98 06 JZ FIN ; FINISHED SCROLLING?
E099 E4 D4 XRI X'D4
E09B 37 XPAH 3
E09C 33 XPAL 3
E09D 90 EE LOOP: JMP ROLL
E09F C4 D3 FIN: LDJ X'D3
E0A1 37 XPAH 3
E0A2 C4 E0 LDJ X'E0
E0A4 33 XPAL 3
E0A5 C4 20 LDJ X'20
E0A7 CF 01 ST 0+1(C3) ; CLEAR BOTTOM LINE
E0A9 33 XPAL 3
E0AA 9C F8 JNZ LINE
E0AC 33 XPAL 3
E0AD C7 FF LD 0-1(C3) ; BACK UP CURSOR
E0AF C6 01 LD 0+1(C2) ; POP LP3
E0B1 33 XPAL 3 ; RESET CURSOR
E0B2 C4 60 ST X'60
E0B4 C8 00 LDJ 0(C3)
E0B6 90 B4 JMP RET

D020 CRSR = X'D020
.END
    
```

## Complete Computer Systems

AFTER A YEAR'S EXPERIENCE AS - THE FIRST MICROHIRE COMPANY - CCS HAVE EXPANDED INTO SALES AND PROGRAMMING\* DIVISIONS

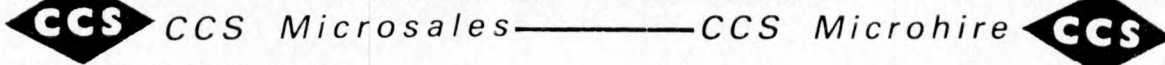

FREE CASSETTE UNIT WITH 32K M/Cs

	16K	£970	48K	£1290
COMPUCOLOR	8K+DISC+CRT			£1370
COMMODORE PET	4K	£460	8K	£550
	16K	£675	32K	£795
EXIDY SORCERER	16K	£750	32K	£850
SORD M100 ACE			price on application	
PLOTTER				£690

We have drawn on our experience of a BIG range of machines to make up a Sales List consisting of machines that represent the BEST in - VALUE FOR MONEY - EASE OF USE - AND RELIABILITY

**CCS MICROSALES** TEL: 01-444 7739  
**22 WESTSIDE** Letchworth 73301  
**68 FORTIS GREEN**  
**LONDON N2**

Still the Leading Microcomputer Hire Company with the best range of equipment: Apple II; PET; Exidy Sorcerer; SEED System One/MSI 6800; NASCOM/MICROS; Research Machines 380Z and Tandy TRS-80.

Send for our NEW PRICE LIST giving the most attractive prices yet. Don't forget our "THREE WEEKS FOR THE PRICE OF TWO" OFFER (From July to September).

Write to address below, or to London for particularly urgent enquiries.

**CCS MICROHIRE**  
**FREEPOST**  
**LETCWORTH**  
**HERTS SG6 4YA**

\* CCS MICROPROGRAMS are actively looking for more programs to add to their range. Even if you want to market your own systems, letting us know can generate more sales for you. If you have any programs at all DON'T SIT ON THEM - TELL US.

Business and Technical systems First Please: Games - later. Write giving details to either of the above addresses.

# Scenes from last year's stunningly great event....

**THE REAL SHOW FOR REAL PEOPLE!**  
 The Show that makes other Shows look like  
 Sunday School outings.

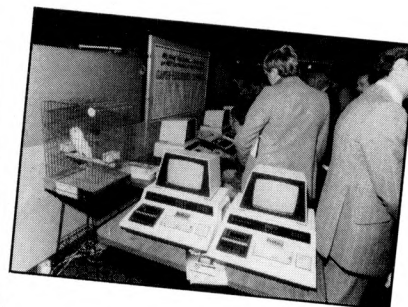
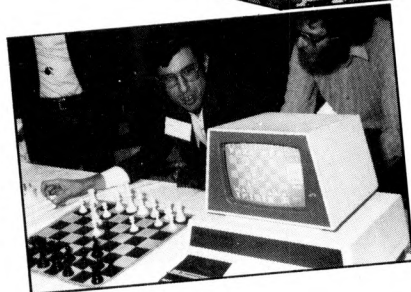
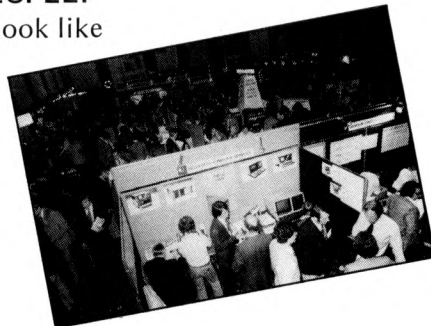

## Now.... the 2nd Great Personal Computer World Show

will be held on

### November 1-3rd 1979

at the West Centre Hotel, Lillie Road, London.

*Excitement . . . hard-headed practicality . . . discovery . . .  
 business . . . the Show that's serious but not solemn.*

- **PCW** readers are truly the shapers of the future of computing in Europe, exhibitors will be taking the opportunity of presenting their latest products.
- The **Features Area** will have: The **PCW** Chess Championship . . . a robot or two . . . individual machines . . . innovations . . . Computer art . . . anything interesting that comes up between now and November . . . the Amateur Computer Club . . . Special School's Section. The Show will be vital, cheerful — and very profitable for visitors and exhibitors alike.

**And for the first time in Europe!**  
**David Hebditch, PCW** Consultant,  
 demonstrating practical communications  
 with personal computers

- **PCW** gives and will be giving consistent support to exhibitors. A comprehensive,

detailed catalogue of products of every size and description will appear in the **October** and **November** issues of **PCW**.

- A three day **Conference** (1st — 3rd November) will be held during the Show.  
**Day One** (Nov. 1st) The Small Computer and the Businessman.  
**Day Two** (Nov. 2nd) Computer Applications.  
**Day Three** (Nov. 3rd) Computing for the home and the amateur.

Over thirty stands have been booked so far . . . with the publicity campaign only just beginning.

Over five hundred enquiries from readers already . . . with information only just being released.

#### The Second Great Personal Computer World Show

- Please book me . . . . . Admission tickets @ £1.00 (15% discount for groups of 10 and over).
- Please send me Conference details.

Name \_\_\_\_\_ Address \_\_\_\_\_

Post to:- Personal Computer World  
 62a Westbourne Grove  
 London W2

\_\_\_\_\_  
 \_\_\_\_\_  
 \_\_\_\_\_

# Hello Z8000

Mike Lord

Now that Zilog are releasing samples of their Z8000 chip, and Advanced Micro Devices have announced that they will second-source it, it is an appropriate time to look at this microprocessor which can outperform many mini-computers; and see how it is likely to influence future generations of personal computers.

## Hardware

The Z8000 comes in two versions which differ only in their addressing capabilities. One, in a 40 pin package, provides 16 address lines. The more complex chip uses a 48 pin package and has a total of 23 address lines.

The data bus is 16 bits wide, and is multiplexed with the low order 16 address lines. Although this means that address latches will be needed to separate data and address signals, address buffers would be needed anyway in any reasonable size system, and a combined latch/buffer

such as Intel's 8282 can be used.

As one would expect in a modern CPU chip, the Z8000 requires only a single (5V) supply and a single phase (4MHz) TTL level clock. To allow it to work efficiently in a multi processor system, CPU flag lines uO and uI control access to critical shared resources. (A multi Z8000 system would make a nice basis for serious chess programmers!) Bus Request and Bus Acknowledge lines allow other parts of the system to take control of the Bus; as for example during DMA transfers.

Of the three interrupt inputs provided, NMI (Non Maskable Interrupt) would generally be reserved for an emergency condition such as

Power Fail. The other two inputs; Vectored and Non Vectored Interrupt Requests, are separately maskable; otherwise interrupt priority must be determined by external hardware.

The four Status output lines STO - ST3 can be decoded to provide information about the processor activity, such as Data, Stack, Instruction or I/O request, VI, NVI or NMI acknowledge, Bootstrap set or reset, Refresh cycle, Internal Operation or Halt. Using these signals, I/O addresses can be separated from memory addresses, and different memories used for Data, Stack and Program storage.

## Addressing & Memory Management

Since the Z8000 is designed to handle 8-bit data bytes as easily as 16-bit words, it has to be able to read or write individual bytes to memory as well as full words. To allow this the Z8000 addresses memory in bytes, and uses the 'word/byte' signal to indicate whether 8 or 16 bit data is to be transferred. When referencing 16-bit words the least significant address bit (AO) is ignored.

The 23 address bits from the 48 pin ('segmented') version consist of a seven bit segment number plus a 16-bit 'offset', allowing 8 Mbytes of address space. In theory, by using the CPU status signals to differentiate between Stack, Data and Program references in both Normal and System modes, one could have 6 times 8 Mbytes of memory on a system, although this would be a very specialised application.

A 48 pin Memory Management chip is being produced to complement the Z8000. This will provide for segment re-location by a logical (software) to physical (hardware) address translation, and will also give a measure of memory protection. In larger systems, address re-location is an important feature as it allows:

- Programmers to write for a 'virtual' memory which is larger than the actual amount of RAM available on the system. The extra data or program is

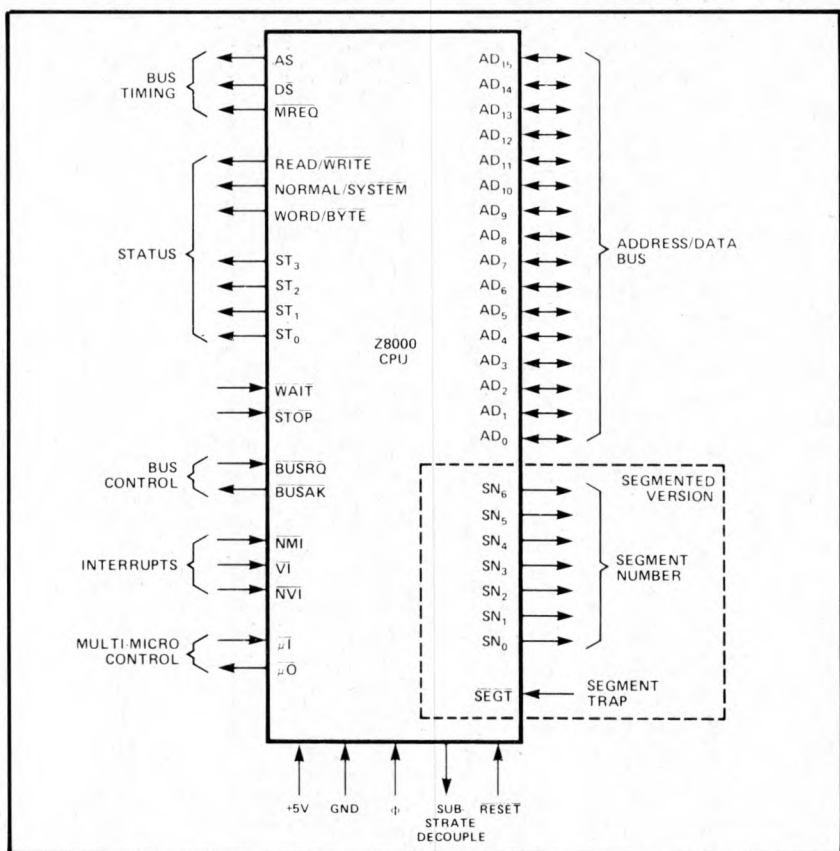

The CPU

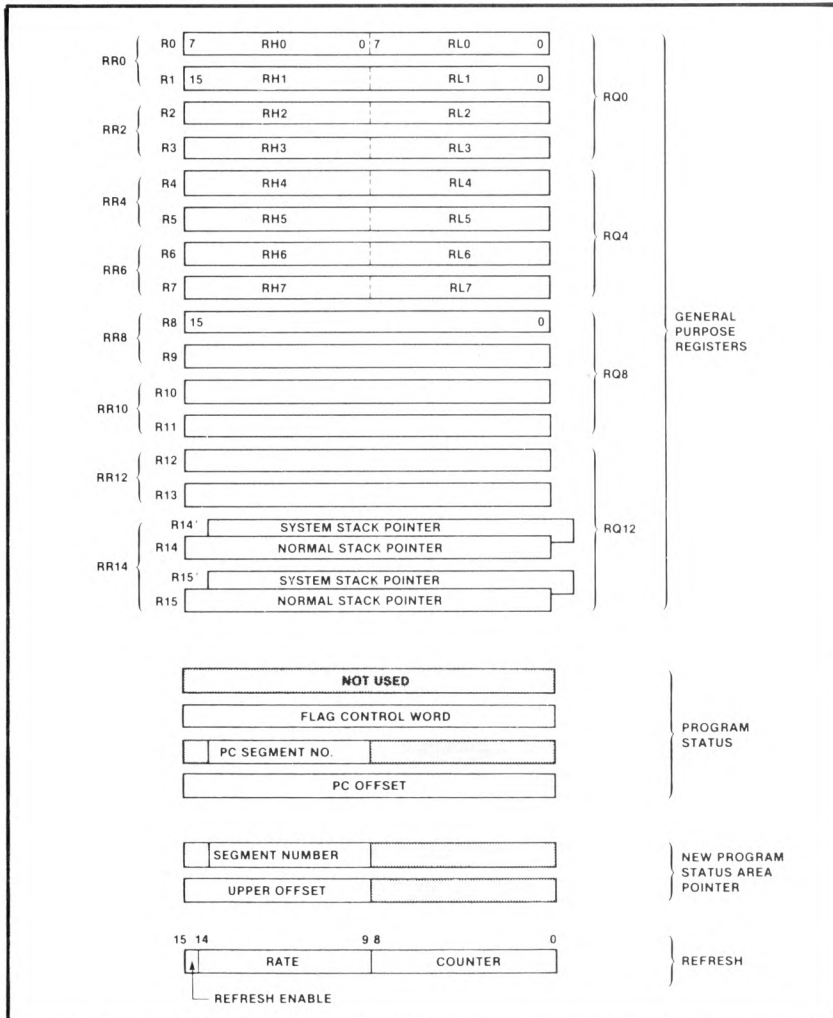

CPU Registers (Segmented Version).

stored on disc and swapped into RAM when called for; address re-location making it appear to be in the right address area.

- A shared program (e.g. a BASIC interpreter on a time shared system) to operate on different data areas by simply re-locating the data addresses.
- Programs and data in a multi-programming/multi-tasking system to be dynamically re-located to make the best use of the available memory space.

**Normal & System Modes**

In terms of raw processing power and address space, the Z8000 is well suited to be used in a multi-tasking or multi-user system. This type of application depends on an Operating System to allocate resources (CPU time, peripherals, memory space) to the various users; and, to ensure that an individual user or task cannot corrupt the rest of the system, it is necessary that:

- The Operating System cannot be 'locked out'; i.e. some aspect of the Operating System must have the highest system priority.
- Memory and I/O requests from an individual task should only be allowed if legal (within the bounds allocated by the Operating System). Any attempt at an illegal access must not be allowed to succeed.

To meet these requirements the Z8000 can run in either 'System' or 'Normal' modes. Separate stack pointers are provided for each mode, and the System stack is used to save the old program status when interrupts or traps occur. Certain 'privileged' instructions are only valid when the processor is in the System mode; particularly those which affect the Memory Management chip. I/O would normally be handled via the Operating System, which can resolve conflicts and attempts at illegal accesses of peripheral devices. The Memory Management chip itself checks the validity of memory addresses against programmed bounds; causing a 'segment trap' if an illegal reference is attempted.

**Registers**

The Z8000 contains sixteen 16-bit registers R0-R15, all of which may be used as accumulators. R1-R15 may also be used as Index Registers, and R14, R15 double as the Stack Pointer.

R0-R7 may also be used as sixteen 8-bit registers (RHO, RLO - RH7, RL7), all of which may be used as accumulators. For long word

(32-bit) data, eight register-pairs are used (R0-RR14), while a few instructions such as Multiply and Divide use the register-quadruples RQ0-RQ12.

The Program Counter is a separate register, as are the program Status Word register and the New Program Status Area Pointer (used by Traps and Interrupts).

Like its predecessor, the Z80, the Z8000 can provide automatic refresh for dynamic RAMs. The Refresh Register allows the programmer to control the refresh rate and count.

**Instruction Set**

The Z8000 can handle seven types of data; bits, BCD digits, 8-bit bytes, 16-bit words, 32-bit long words, byte strings and word strings.

The basic instruction set provides the usual set of arithmetic and logical instructions, most of which can be specified to operate on bytes, words or long words, plus some less usual types such as Move Multiple Registers to/from memory and Load Address (the address of the 'operand' is loaded into the specified register). In most cases a register must be either the source or the destination of a data manipulation instruction, although the contents of memory locations can be directly transferred to or from the stack (PUSH & POP).

Signed Multiply and Divide Instructions can handle 16 or 32 bit operands. INC and DEC, increment or decrement a byte or word in a register or memory location by any number from 1 to 16. Similarly, bytes, words or long words can be shifted left or right by any number of bits by a single instruction.

For fast loops, a Decrement (register) and Jump on Non-zero instruction is provided and has a relative jump range of 0 to -256 bytes.

The System Call (Trap) instruction allows user programs running in Normal mode to communicate with the Operating System; as, for example, to request I/O routines. The instruction carries a programmer specified value (0-255) to specify which system routine is being called.

The most notable feature of the Z8000 instruction set must be the comprehensive range of Block Transfer and String Manipulation instructions. These operate on byte or word strings in RAM, string length being held in a register. Working in either autoincrement or autodecrement mode, a string can be searched for a particular byte or word, strings can be searched for a particular byte or word, strings can be compared, or copied into another area of memory,



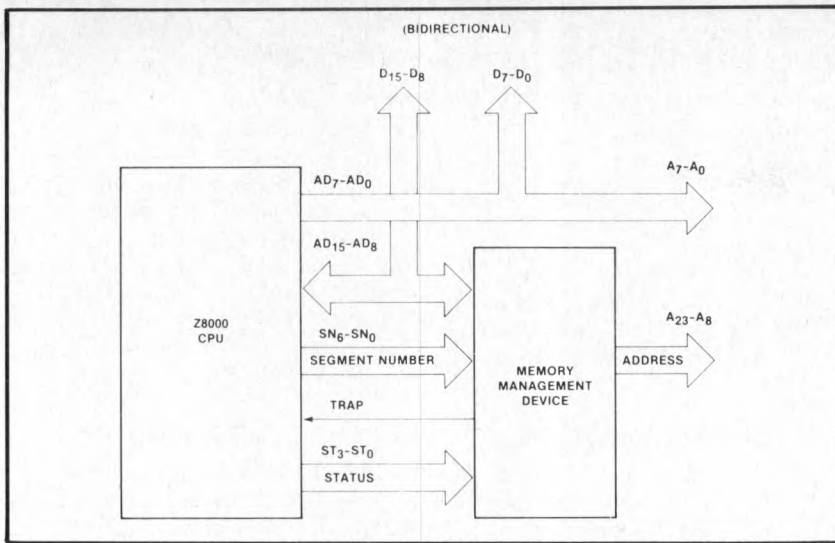

Memory Management Device with Z8000 CPU.

or translated via a look-up table. Considering how much time Compilers and Interpreters spend performing this type of function, these special instructions should give a significant improvement in program run times. The I/O instructions include similar block move commands, useful for high speed data links.

**Performance**

While it is impossible to make a precise comparison of processors, as so much depends on the particular application and the skills of the programmer, it is possible to get a feel for their relative performances by looking at the instruction times for common instruction types. On this basis, the Z8000 is slightly faster than a PDP 11/45, and almost twice as fast as a 4MHz Z80; e.g. a 16 bit LOAD register from memory instruction takes 2.25, 2.86 and 4uS respectively. But the enhanced instruction set will also have an effect on the execution time of real programs. So, bearing in mind the power of the Z8000's Block & String instructions, and the 16 and 32 bit arithmetic capability including multiply and divide, Zilog's claim that the Z8000 will perform some 5 - 10 times faster than existing 8-bit microcomputers is believable.

**And what shall we do with it?**

So, we now have a micro which, in terms of speed and address range, is more than a hundred times faster than the 8008 which launched the whole personal computing scene. And the cost of memory is falling every day. And hopefully someone will produce the software to match the Z8000's power. So, the question must be; do we want it - what can we do with it?

One area will be applications where running time is critical, or at least annoyingly long on present microcomputers. Chess, for example, and computer animation. Also time-shared systems such as multi-user BASIC. Coupled with increasing memory size, and perhaps using virtual memory techniques, micro based real-time multi-tasking systems become more realistic. Surely the microcomputers developed around the Z8000 will have at least a rudimentary provision for connecting

multiple terminals; if the price is low enough this makes sense even in the home or small business environment. And surely another use for increased computer power will be to take some of the load from the user; by higher level languages that are easier to program in; by more 'intelligent' checking of input data and program structure; by providing more helpful error messages; and by implementing automatic hardware and software error detecting or diagnostic routines to give immediate warning of system failure.

And finally, bearing in mind that memory may be getting cheaper but 8 Mbytes represents an awful lot of programming effort, we will see a tendency towards 'sloppy programming'; that is, the use of techniques which may be extremely inefficient in terms of computer utilisation, but which get the job done at the minimum cost. After all, if the machine is powerful enough to cover up for long winded algorithms, who cares? If the computer responds to a query in a quarter of a second instead of a theoretically achievable tenth of a second, who is to tell the difference? And if a 16k byte ROM containing a collection of utility routines is cheaper than writing the hundred or so bytes of code that are needed for a particular job, then why not use it?



**are . . . software . . . software . . . software . . . sof**

Ready to use, Commercial and other software packages are now available for your Apple II

**Mailing and Addressing**

Build up a mailing list with this program! Addresses of customers and enquirers can be kept on file for use with all direct mailing applications. Can be sorted by up to six parameters and printed onto envelopes or labels.

**Word Processor**

Standard letters can be typed into your Apple and saved onto disk for future use. Features include: line insertion/deletion, justification, line centering and replacement of strings. After editing, your letter can then be printed in both lower and upper case.

**Estate Agents Management**

Allows information of house purchaser and vendor to be held on file, referenced uniquely by a house code. Produces house adverts and keeps a record of advertising accounts, the word processor facility allows letters to solicitors, building societies etc. to be produced. A house enquiry routine is also included.

**Dual Disk system £50.00**

**Single Disk System £50.00**

**Dual Disk System from £250.00**

Other programs include: Incomplete Records Accounting, Information Retrieval, Shape-Create, Sales Ledger, Order Entry Invoicing, Management Information, Roots of Polynomials, Matrix Inversion, Microcode Assembler, Regression, Variance, Standard Deviation, Correlation, Datatesting, Co variance of a Time Series, plus a variety of Games. Dealer discounts available.

Name .....	Please send me .....	I enclose cheque/PO No. ....
Address .....	.....	Please debit my Access/Barclaycard
.....	.....	Account No. ....
.....	.....	.....
.....	.....	Amount .....

All prices include VAT and carriage.

Cut out and send to:-

**Keen Computery Ltd., 5 The Poultry, Nottingham Tele: 583254/56**

**are . . . software . . . software . . . software . . . sof**

**Expand your Pet to its full capability with these professional peripherals**

**Dual floppy disk unit**

A COMMERCIAL GRADE DISK SYSTEM FOR THE PET

- Up to 800K Bytes on Line Mass Storage
- High Speed D.O.S. in ROM
- Effectively doubles PET operating system commands
- Complete documentation allows use of full resources
- Handles up to four disk drives
- Includes Commercial Printer Support
- Adds 16 commands to PET basic
- Automatic self reorganisation of free space on disk after each save or erase command
- Free space is never fragmented

PRICE £840.00 + VAT

**Plessey Petite add-on memory From Europe's largest memory board supplier**

Stand-alone, plug-in memory expansion. Available in 8K, 16K, 24K, and 32K versions. Complete in case with built-in P.S.U.

24K £449.00 + VAT



**Software**

Estate Agency: Very cheap, very effective method of showing properties to customers. Automatic deletion. Printed copies for prospective purchasers (Now available on disk). £25.00

Mail List: Printout all your mailshots, names and addresses; printout on self-adhesive labels; disk only, £15.

Payroll: Complete suite, abundant storage on disk. End-of-year summary; coin analysis; two payslips; excellent value; disk only, £50.

We supply all Commodore, Petsoft and Compuette programs. We should be glad to quote for dedicated software applications.

R.H. Mastermind: Surely the best Mastermind ever. 3 Games levels. £5.00

R.H. Shape Matching: Match up two different shapes to score. You against the other guy. You will have to be sharp for this one. £5.00

**Expandem memory expansion board**

General purpose expansion system for PET and other 6502 Computer Systems (e.g. KIM, SIM, AIM).

- 24K to 32K Low Dissipation RAM
- Mounting slots for 4 option cards
- All necessary cables and brackets
- Disk Controller
- Parallel I/O
- Sockets for Eprom
- Flexible Serial I/O
- S100 I/O Driver

24K Board £320.00 + VAT

PET 2001-4 4K Bytes of Memory £460.00 + VAT

PET 2001-8 8K Bytes of Memory £550.00 + VAT

PET 2ND Cassette Unit £55.00 + VAT

PET Sound Box Plugs direct into 2nd Cassette Port complete with Demo Software £12.98 + VAT

PET Dust Covers To protect your PET—(Four Colours) Rust, Blue, Beige, Green £8.33 + VAT

PET TV Interface Plugs direct into user port Superb Specification £45.29 + VAT

Access and Barclaycard accepted for Telephone and Postal Orders.

All prices include post and packing (insured post extra).

We should be glad to discuss your problems or requirements relating to technical matters, software, etc—in-house software experts available.

Dealer enquiries invited for all our stock items.

U.K.-wide service by our specialist technical staff. Maintenance contracts available after our one-year guarantee at 7½% of capital purchase price.

All new equipment sold by us carries a 12 months' guarantee

**HB COMPUTERS LTD**

Computers for Business & Home

22 Newland Street  
Kettering Northants  
Telephone (0536) 83922/  
520910



David Goadby *Strumech Engineering Electronics Developments*

The 6800 microprocessor is probably the most popular amateur "chip" in use (certainly in the Midlands) and I have seen many machines based upon it. A lot of the designs whilst being very commendable are often unsuited to running commercial software packages. The reason is that many such products assume either Mikbug or one of the many derivatives (lookalikes) that are available. The traditional Mikbug machine has its I/O at 8000 and various other oddball memory addresses like A000 making the memory map quite a headache. The system is quite constrained and particularly so if you want to put 60k of RAM in it! Another hazard is the pocket, if you can't afford a nice VDU or TTY but you *can* afford a Creed 7B then you have to do ASCII to Baudot conversion, as well as tackle the problems described. (See PCW April '79 for article on Creed 7B).

**Universal Solution**

Somehow a universal solution was required to overcome the melee of homebrew monitors and "thin

wallet" I/O enabling everyone to use 8K Basics, Startrek and the like.

The idea of a machine-independent (SWTPC, MEK, MSI etc), monitor-position independent (put it anywhere you like), and I/O-independent monitor seems a bit like Utopia but it is certainly possible with the

monitor I use.

I used to work for IBM and I remembered how the Jolly Giant used to call supervisory functions, namely the SVC (supervisor call). The call was followed by a byte which was the call number (to select the routine you wanted) and the SVC worked by causing an interrupt, the SWI instruction also caused an interrupt so there was the answer . . . (Eureka?).

My particular machine was a SWTPC with 32k RAM and memory mapped VDU with parallel ASCII keyboard, and later on a MSI processor with minifloppy disks. The software, once patched, was easily transported to my MSI processor and disk operating system. In a SWTPC system I had to use a prom-vertor to enable replacement of the Mikbug prom by a 2708.

The actual call mechanism I used is illustrated in fig. 1. The SWI is followed by a single byte which is the call value. When the SWI occurs then the 6800 processor will load an address from location FFFA (Hex) and this is the address of the monitor (within reason, anywhere you like).

The monitor then has to get the call value ready to work out the routine required, this is done by using the program counter value on the stack. Since, when the SWI occurs the program counter +1 (for the return) is stored on the stack, then this value points to the call value.

Since we do not want to return to the next location (as this is the call value) we increment the program counter value on the stack. The call value is doubled and is used as an index pointer into the call jump table. The routine is jumped to (using JSR) and after execution we can either return directly using the RTI instruction or, if return register values are required, then these must be placed on the stack before the RTI instruction is executed.

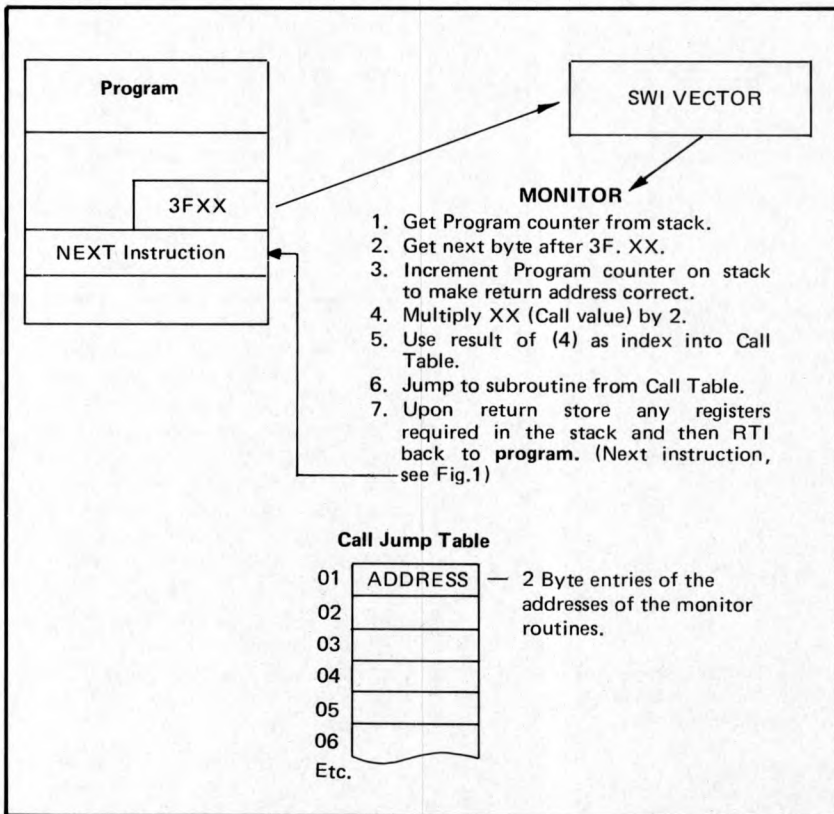

Fig. 1. Call Mechanism

The mechanism I used appears to be the best compromise bearing in mind the compatibility that is required with Mikbug machines.

**The Stages**

To implement such an operating system requires two stages. First: identify where existing monitor calls are, using a search routine to assist you. Second: replace existing routines with SWI calls. There are two types of monitor calls that you are likely to encounter

**1. JSR XXXX**

where XXXX is the monitor routine address.

Replace JSR with 3FYY01 where YY is the routine call value, the NOP pads the instruction back to three bytes.

**2. JMP XXXX**

Here the JMP is replaced by 3FYY39. The 39 (RTS) is there because some programs, to save space, have a single jump point and monitor calls are made using BSR's (Branch Subroutine) to the jump instruction and the RTS (Return Subroutine) instruction will be the last one in the monitor subroutine. In our system all returns are made to the byte after the call value so we

put a return subroutine instruction in, to complete the sequence.

It would be only fair to list the advantages and disadvantages of my system, so here goes:

**PROs**

1. Machine type independent (so long as it's a 6800!)
2. I/O independent (VDU, TTY, LED's etc; your mix!)
3. Software is fully compatible once standards established.
4. All monitor calls are 2 bytes in length.
5. Existing software easy to modify once you've found the places to change.

**CONs**

1. All software *has* to be patched to enable to be used with the monitor unless you run two monitors.
2. Slightly greater overheads, but only noticeable when using very fast terminals (19200 Baud); but who needs data transfer that fast anyway?
3. No currently available standards, so you're on your own!

Figure 2 shows the calls I used and it is by no means complete or definitive.

When writing in assembly language you can define the calls thus: INPUT EQU S3F01; then, when an input is required, code the following: FDB INPUT.

If you have written your own assembler then you can write your own for the calls eg: OUT, IN, DOS, etc.

**CALL TABLE**

Call Value	Function or Mikbug equivalent
01	OUTEEE (To your output device)
02	Register dump and enter monitor
03	OUT HXL
04	OUT HXR
05	Output Carriage return line feed
06	Register dump and return to program (Debug)
07	OUTS
08	BYTEOP Output A Reg. as a byte
09	Input 8 bits from input device (for binary loaders)
0A	INEEE
0B	INHEX
0C	BYTE
0D	Get address and return it in X Register
0E	OUT 2HS
0F	OUT 4HS
10	PDATA 1
11	Output 8 bits to output device (Binary dump)
12	Print error Msg. and return to monitor
13	Monitor entry via initialize routines
14	ACIA Input routine, port number in B
15	ACIA output routine, port number in B
*16	PIA input routine, port number in B
*17	PIA output routine, port number in B
18	Delay: Time depends on value in X Register
19	Task swap
1A	Get time and date
1B	ACIA poll to see if input pending (Port in B)
1C	PIA poll to see if input pending (Port in B)
1D	Message print, Msg number in B register
1E	Call multi-tasking executive
1F	DISK FILE MONITOR CALL (DOS)
20	Memory Bank Switch
21	Multiply Routines
22	Divide Routines
23	User defined Call (Set by user program).

\*with handshaking

**ADVERTISERS' INDEX**

Abacus Computers Ltd.	68	London Computer Store	12
A.J. Harding (Molimerx)	30	Look In	58, 59, 60, 61
Almarc Data Systems Ltd.	62	Microbits, Microbusiness	67
Bristol Computer Centre	36	Micro Software Systems	12
The Byte Shop Ltd.	27	New Bear Computing Ltd.	56
C.A.V.S. Ltd.	33	Ohio Scientific	64
CC Soft	73	PCW Show	46
CC Systems	45	Peripheral Hardware Ltd.	4
Comart	8	Personal Computers Ltd.	2
Comp Shop	78, 79	Petalect	11
Computastore	4	PET News	22
Computer Workshop	Back Cover	Plessey Microsystems	3
Crystal Electronics	12	Research Machines Ltd.	40
Equinox Computer Systems Ltd.	66, 73, 77	Rostronics	11
Factor One	6	SEED	28
Gemsoft	30	Sintrom Microshop	41
Happy Memories	12	Sirton Products	69
HB Computers Ltd.	50	Small Systems Engineering Ltd.	66
Integrated Circuits Unlimited	63	Technalogs	11
Interam	7, 73	Terminal Display Systems Ltd.	71
Inter Systems	72	Transam Components Ltd.	33
Keen Computers Ltd.	26, 50	TVJ Microcomputers Etc.	18, 19
L & J Computers	30	V & T Electronics	33
LP Enterprises	34, 66	Videotime Products	17
LTT Electronics	54	Xitan Systems	36

**A refreshing swim**

The article has, I hope, stimulated some thoughts and possibly some standards could be set up around the idea. The universal program seems an almost impossible dream, but with this system I believe that we can get very close to it. As a sweetener the 6809 (the 6800's successor, to Z80 freaks) has three software interrupts and SW2 has been deliberately kept "nondedicated" by Motorola so the system can be carried over into the next generation of machines; which means that any work done now is not wasted at all.

Finally, you might ask, where does SWIM come into it? — obvious really: SoftWare Interrupt Monitor. (PCW Note: Mikbug is a trademark PCW)

# PCW OPEN PAGE

## THE AMATEUR VIEW

Mike Lord

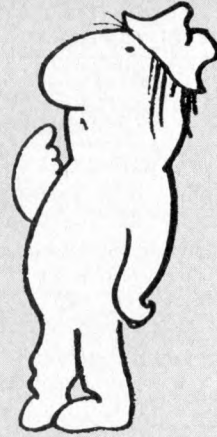

### MORE FROM THE CLUBS

Mr. M.J. Patrick of 28 West Drive, Cheam, Surrey, is interested in forming a microcomputer group serving *North/North-East Surrey* (centered around Sutton) and invites prospective members to write or 'phone him on 01-642 8362. He is also trying to set up a *Sorcerer User Group* — on a national basis — and would welcome enquiries from owners or users of this machine.

Des Wood writes to say that there is now a group going in *Scarborough*, meeting once a month at the Talbot Hotel in Queen St. Anyone wishing to go can ring 63982 for details of the next meeting.

The *Nottingham Micro Computer Club* started last year by Mr. Braga has now established regular meetings; at 7.30 on the first Monday of each month in the Trent Polytechnic, Newton Building, Burton St. Mr. P.C. McQuoney is the club secretary and enquiries should be addressed to him at 28 Seaford Ave., Wollaton, Nottingham. He would also be interested to hear of any co-ordination between the various user groups (P.E.T., Tandy, Apple, etc.) as the exchange of BASIC software, with appropriate modifications, should be possible and could benefit everybody.

## POP SHOP

*The PCW Open Page Service for amateurs. Buy, sell, exchange —  
One-off advertisements only accepted. Not more than 50 words.*

**SWTP 6800 MK II Computer.** SWATBUG Monitor, 16K fast RAM, Serial Interface, SWTP tape interface for two tapes on full auto. Terminal with Cherry pro keyboard, works up to 19,600 Baud. Over £100 Software free, includes co-res, two versions 8K BASIC, 3K BASIC, disassembler, etc.

Cost over £1000 — **open to offers**  
ring (0244) 547575

**FOR SALE: 7768 4K RAM BOARD** Intel 450ns Low Power RAM Chips, All I.C's socketed. Offers write — **N.K. Wright, 25 Penny Park Lane, Coventry, West Midlands CU6 2GU.**

### EXTENDED NASCOM 1 COMPUTER

With T4 Monitor, 2.5A Power Supply, 3-Slot Nasbus, Buffer Board, 8K RAM + Tiny Basic, All mounted with keyboard.

**£360.00 o.n.o.**

Also Elektor SC/MP RAM I/O + CPU, 5v 1A Supply, ideal for experiments. **£20.**

**John Oliver. London 01-886 5046**

### FOR SALE

**KSR 33 + 10 Rolls of Paper £225**  
Tel: 025 125 4217

**TRS80 LEVEL II 16k RAM + Expansion Interface** As new + boxed. Will accept **£700**

**Tel: Low Fell (0632) 872991 after 6pm**

### NASCOM 1 MICROCOMPUTER

For Sale: Nascom 1, fully working & virtually unused. Consists of CPU board, keyboard, 3A PSU, high resolution modulator + CPU controlled cassette deck. All housed in Custom Verocase. All Manuals & assorted programs.

**£295 o.n.o.**

Tel: 021-382 5815 evenings or weekends.

**FOR SALE: ELF II COMPUTER** with Manual & Expansion Power Supply. Fully working and housed in a temporary case **£85.00 o.n.o.**

**Ring 0602 266748 (Weekends Only)**

Some 4096 Bit Dynamic RAM Chips @ **£1.99 each.**  
Some DRAM Refresh Control Chips @ **£1.99 each**  
One ASCII Touch-Type Keyboard Kit @ **£25 unused**  
One 8080 CPU System with Power Unit @ **£199 working**  
St. Albans 64077 after 7 pm

**FOR SALE**  
**OSI SUPERBOARD II £230**

(New — Must Sell)

M. Lawrence 01-253 4321 (Daytime)

### FOR SALE

**SILENT 700 TERMINAL** 30 cps thermal printer with manual **£380**

**Tel: 0582 603027 evenings.**

### FOR SALE

**HEWLETT-PACKARD HP-25 PROGRAMMABLE CALCULATOR**

49 Steps (147 Keystrokes), 8 register, 4 entry memory stack. Complete with Users Guide, Applications Manual and mains unit **£40 o.n.o.**

**Phone: Peter Lusmore Guildford (0483) 36311**

### FOR SALE

**Thompson 'superchip' VDU and GRI 756 Keyboard** in separate boxes with connectors and power supplies with lead to TV set. In good working order.

**VDU £130 Keyboard £70 together £195**

DEC memory board for CSI 11 MSVII-DC 16k by 16 bits hardly used **£700 or best offer**

S. Eisenbach 01-794 8419

**NASCOM MICROCOMPUTER** In Nice Cabinet with heavy duty fan cooled and protected power supply. Cuts Interface, B-Bug, Cassette Deck and all Data Books. Keyboard on Wooden Plinth. **£250**

8k of 4027 Dynamic Ram **£40**

**C.R. Bonner (G3TGF)**

29 Hillcrest Road, Orpington, Kent.

Tel: Orpington 26802

### STAR CLUSTERS V BYTES

For exchange. 900mm professionally made, Newtonian astro-telescope outfit. Excellent (refigured mirror) eye pieces, equatorial mount on tripod, barlow etc. Cost **£230**. Exchange for sound Nascom or similar, Texas 159 etc. Cash adjustment if appropriate.

**Sam Weller, St. Just Cornwall 788217 Day or 788286 Evenings.**

**SORCERER OWNERS.** Programs available including Tiny Pilot, Auto Line No. Etc. Etc. Also similar progs for PET, on Tape.

Contact: **Pete Scargill & Jim Cocallis** at  
24 Percy Park, Tynemouth, Tyne & Wear

**PET 4K FOR SALE.** Only Three Months Old, including Pet Owners Club Manual. Price **£410.00**

Tel: **Maidstone (0622) 43337**

**TRS-80 LEVEL 1** 4k perfect working order, hardly ever used. **£350 o.n.o.**

Contact: **P. Bryant** 2 Broom Road, Sittingbourne, Kent. 22753

**SWTP 6800 MK II Computer** SWATBUG Monitor, 16k fast RAM, Serial Interface, SWTP tape interface for two tapes on full auto. Terminal with Cherry pro keyboard, works up to 19,600 Baud. Over £100 Software free, includes co-res, two versions 8k BASIC, 3k BASIC, disassembler, etc.

Cost over **£1000** — open to offers  
Ring **(0244) 547575**

**FOR SALE 7768 4K RAM BOARD**

Intel 450ns low power Ram Chips, all I.C.'s socketed. Offers. Write — **N.K. Wright, 25 Penny Park Lane, Coventry, West Midlands, CU6 2GU.**

**EXTENDED NASCOM 1 COMPUTER**

With T4 Monitor, 2.5A Power Supply, 3-Slot Nasbus, Buffer Board, 8K Ram + Tiny Basic, All mounted with keyboard.

**£360.00 ono**

Also Elektor SC/MP RAM I/O + CPU 5V 1A Supply, ideal for experiments. **£20.**

**John Oliver. London 01-886 5046**

**NASCOM 1 FOR SALE**

Plus Ithaca 8k Static RAM Board, COMP S100 expansion board and 3A PSU. Various game programs, 2K BASIC ontape. Fully working + all manuals.

**£350**

Tel: Wakefield 79163

**MK14 SCMP MICRO For Sale.** Built and Working, with Extra RAM, Improved Monitor, updated documentation. **£45.** Cuts interface extra.

Tel: **J. Wragg, Chesham 3744**

**FOR SALE — NASCOM 1**

Fully built & tested, beautifully housed in wooden cabinet. TV modulator + all the manuals and taped programs.

**£225 ono**

**T D Botterill, 48 Yardey Drive, Northampton**  
Tel: Northants 844338

**TRITON COMPUTER,** No Case, Hence **£195 o.n.o.** or exchange Hi Fi Cassette Deck, or Portable Colour TV.

Ring **Mike Gill** on Huddersfield (0484) 44176  
6 — 8.30 pm.

**TRITON 8K EPROM EXPANSION CARD** ready built (without eproms) **£35.00**

**7 Bonsor Road, Folkestone Kent.**

**MK14 SCMP MICRO FOR SALE.** Built and working, with extra Ram, Improved Monitor, Updated Documentation. **£45.** Cuts I/face extra.

Tel. **J. Wragg, Chesham 3744**

**NASCOM 1 FOR SALE**

Plus Ithaca 8K static Ram Board, COMP S100 expansion board and 3A PSU. Various games programs, 2K Basic ontape Fully Working + All Manuals **£350**

Tel: Wakefield 39163

**SCIENCE OF CAMBRIDGE MK14 Microcomputer.** Many extras and options: extra RAM, cassette interface, revised monitor PROM, new keyboard, PSU, full documentation **£60**  
Tel: **061-224 0717 (evenings)**

**OHIO SCIENTIFIC CHALLENGER 1P** with full 8K Basic/M-Code, u/I case, graphics, 4K RAM, cased with 4½ amp supply. Free UK supply adaptor — bought March. Sale

**£400 ono** + p+p in carton.

Contact: **Myb Shahid**  
**44 York Street, Walton, Liverpool L9 1BW**

**PET FOR SALE**

**8K Pet 2001-8** Six months old hardly used. With set of work books, microchess, ten spare tapes. **£500**, offers welcome.

Phone **Headley Down (0248) 712206 (evenings)**

**FOR SALE**

**TRS-80 Level II Basic £395**

5 Months Old — As New  
VDU, Keyboard and Cassette

Tel. **Holmes Chapel (0477) 37080**

**FOR SALE**

**TRS-80 Level II, 4K,** keyboard unit only, bought late April, hardly used **£275**

**Andy Crofts, 141 Greville Road, Warwick**  
Tel: **0926 43868**

**FOR SALE — NASCOM 1**

Fully built & tested, beautifully housed in wooden cabinet. TV modulator + all the manuals and taped programs.

**£225 ono**

**T.D. Botterill, 48 Yardey Drive, Northampton**  
Tel: **Northants 844338.**

**TRITON COMPUTER,** No Case, Hence **£195.ono** or exchange Hi Fi Cassette Deck, or Portable Colour TV.

Ring **Mike Gill** on **Huddersfield (0484) 44176**  
6 — 8.30 pm

**CASSETTES**

I have a large quantity of brand new, High Quality Cassettes which are ideally suited to programme storage because they are only 10 mins per side.

Price: **£1.00 each** (inclusive of library case, postage etc.)

**S.G. Smith, 81, Cholmeley Road, Reading Berks.**

**For Sale: Dual 8cm Shugart disc drives:** Includes power supply and I/O cable. Both enclosed in aluminium case. Nearly new. Offers.

Write **Flat 5, 46 Blackwater Road, Eastbourne BN20 7DH.**

**TRS-80 LEVEL II 16k** with numeric keypad, as new — only two months old. Complete with video and cassette deck, lower case, KBFIX some games programs. Owner has genuine reason for selling. Price **£600**

Phone **Romford (70) 48786**

**GODBOUT  
Computer Products**

**Altair/Alpha Micro/Imesai/Cromemco/Polymorphic  
Etc. S—100 Bus Computer Compatible Products.**

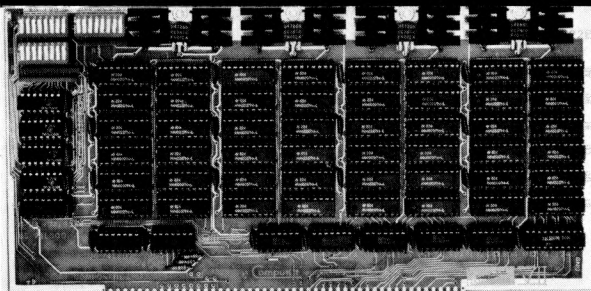

*LTT ELECTRONICS has one of the largest stocks of Godbout computer products in the U.K. Only by bulk purchasing and minimising sales overheads can we afford to sell at what amounts to trade prices.*

For example:	Kit	Ass.
Econoram II, 2MHz 8K bytes	£ 85	£ 99
Econoram IV, 4MHz 16K bytes	£175	£195
Econoram VII, 4MHz 24K bytes	£255	£275
Econoram X, 4MHz 32K bytes	£325	£359
Econoram XIII, 4MHz 32K bytes, B.S.	£345	£379

All prices include postage and insurance (overseas add £10)  
Add 15% VAT.

Further 2½% Discount for cash with order.  
Also Education/OEM discounts on application.  
Send S.A.E. for details.  
MAIL ORDER ONLY.

**LTT ELECTRONICS**

**8 Waldergrave Road, London S.E.19.**  
Telephone: **01-828 1785**

# PCW Book Review



Michael James

## BASIC COMPUTER GAMES

Ed. by D.H. Ahl, 1978

183 pages & 101 programs,  
(Workman Publishing, 8" x 1" £4.50)

This is a collection of 101 games written in Microsoft 8080 BASIC (MITS Altair Rev 4.0). Only the minimum of advice about conversion to other BASIC's is given. An important omission is that some do not allow logical connectives in IF statements and while

IF "condition true" OR "condition true" THEN . . . is easy to convert into two IF's,

IF "condition true" AND "condition true" THEN . . . is more difficult. However, don't be too put off by this, for it's all a matter of knowing your own version of BASIC well enough. If you do, then conversion will be easy. If you don't, then certainly you will after converting a few of these games!

Each program is provided as a reasonably clear listing along with a sample run — invaluable for debugging — and usually a small amount of comment. A pleasant extra feature of this book is the drawings by George Beker scattered throughout.

As I can hardly comment on each of the 101 games, I will list some of the more noteworthy: Super Star Trek (the Klingons even move about), Poker, Mastermind, Hammurabi (a "run a country" game), Civil War (a rerun of civil war battles with you in charge), Checkers (draughts, I think!) and Blackjack. I tend to prefer games that involve an element of skill or that produce interesting graphics, and the bulk of these 101 programs rely on luck too much and become boring quickly. This is not so much a criticism of this collection of games, but more of the general level of game playing that is possible without extra input devices such as joysticks, slider controls, etc. If you're limited to a standard VDU or printer, then you run out of simple games very soon and the more interesting ones such as Chess need a book each.

A second boring aspect of any collection of programs in book form, is the need to type them in. Surely we have reached the stage when we can exchange programs in machine readable form? Obviously not!

In conclusion, this is a good collection of a wide variety of games. The ones I've tried work and have kept me amused. If you're looking for some computer games, then £4.50 is well spent on this book.

## COMPUTER MODELS IN THE SOCIAL SCIENCES

R.B. Coats and A. Parkin, 1977

184 pages, (Edward Arnold, 7" x 8 3/4" £3.75)

At first sight this might not look like a book that would interest the computer hobbyist, but before you pass on to another review or article, let me say that you need not be put off by the words "model" and "Social Sciences". This is a practical book about programs and programming. It contains much that would be valuable to anyone interested in using computers to solve problems — for fun or profit! Slowly the reader is introduced to the idea of computer modelling (or simulation) as a method of obtaining information that would be too difficult to calculate. We begin with an amusing description of how the treasurer of the Ruritanian Sports and Social Club decides — using a simulation of the weather and hence income from the various outdoor functions to be held in the following year — how much the club can afford to spend. A very readable and painless introduction to computer simulation indeed.

After being convinced that computer modelling is a good idea, we are taken through the problems of Erewon Airport, and answer the question of how many runways it needs. This serves to introduce the simple building blocks of models: events, queues, entities, etc.

Chapter four, "Experiments with Computer Models", deals with what should be done with a computer model after it has been constructed — how one should obtain results and test assumptions. This area of the subject always threatens to become very theoretical, but this is avoided and the chapter never loses sight of why we are building (and hence testing) a computer model.

The second half of the book is a collection of examples. The first is a program "TIM", supposed to be a first approximation to the workings of human memory. Whether it is or not is difficult to judge, but it is very interesting and should be a great deal of fun to play with. How it fits into the general picture of a computer model is not clear; it's a rare example of a non-stochastic (stochastic random) model that's not based on a set of equations.

The second example is of bed usage in a surgical suite and as such is a more standard type of simulation problem. It is well explained but not as exciting as the first model.

The third and last example is an economic model. Parameters that define the economy can be adjusted and the outcome judged by the GNP, % unemployed, etc. The purpose of this simulation is to teach students the various economic concepts such as the Philips curve, multipliers, etc. Unlike other "run a country" games, eg. Sumer, King or Hammurabi, this model is supposed to be a reasonably accurate representation of economic theory — and hence is not strictly speaking a game!

No complete computer program listings are given and the ones that are, are in FORTRAN. This need not worry anybody however, because FORTRAN is very close to BASIC and the descriptions and flow charts are enough, in themselves, to allow anyone to write their own versions of the simulations.

In conclusion, the book is well written in a chatty style. It seems to have been reproduced directly from a typed manuscript but is, even so, very clear and easy to read. If you are interested in any of the examples, then this book is for you. If you are interested in learning about simulation techniques, then don't be put off by the "Social Sciences" part of the title.

**AVALON Software announce:**

**ZEN** ..... a complete Z80  
Editor/Assembler

**£14.50 all inclusive.**

- Ready to run on NASCOM 1.
- Cassette, Manual & Listing supplied.
- Runs in 3.5k.
- Full Editor included.
- Compact source files, no line numbers.
- Tape files in fast binary format.
- Interactive ZILOG standard Assembler.
- Decimal, Hex & Octal constants.
- Six math/logical operators.
- Elegant pseudo-ops.
- LIST to Video or Printer.
- OBJECT to Tape or Memory.

available immediately from:

**NewBear Computing,  
40 Bartholomew St.,  
Newbury,  
Berks.**



# NewBear



**NEW BASF 5 1/4 ins disk drives**

**BASF 6106** - slimline  
Double density £220.00 8% VAT

**BASF 6108** - slimline  
Double density  
Double sided £279.50 8% VAT

**MEMORIES DOWN IN PRICE**  
**4116 only £8.50**

2102-1	£0.85	2708	£6.99
2102L-1	£0.99	SWATBUG	£16.00
2112	£2.25	MC 6803L7 (MIKBUG)	£13.65
2114	£6.99		plus 8% VAT

**WE STOCK**

VERO. OK TOOLS. JIM PAK. NASCOM. SYM-1.  
ITHICA AUDIO. 77-68 BEAR BAGS. SORCEROR.  
HORIZON AND MUCH MORE...

**INTEGRATED CIRCUITS**

**Microcomputing I.C.'s**

MC 6800	£7.15
MC 6821	£4.63
MC 6850	£6.74
MC 6810AP	£3.61
MC6840	£12.72
MC8602P	£2.88
MC 14536P	£3.69
MC3459	£2.43
Z80 CPU 2.5MHz	£8.99
Z80 PIO 2.5MHz	£7.99
Z80 CTC 2.5MHz	£7.99
Z80A CPU 4MHz	£13.99
Z80A PIO 4MHz	£10.00
Z80A CTC 4MHz	£10.00
SC/MP11	£8.88
(INS 8060N)	
INS 8154N	£8.18
8080A	£6.00
6502	£12.00
6522	£6.58
6532	£12.56

**NEW**

100.0	KHz	£3.25
200.0	KHz	£4.20
204.8	KHz	£3.25
1.0	MHz	£3.50
1.008	MHz	£2.80
1.8432	MHz	£2.80
2.0	MHz	£2.60
4.0	MHz	£2.60
5.0	MHz	£2.60
10.0	MHz	£2.60
13.478	MHz	£3.25
36.0	MHz	£3.25

plus 8% VAT

**INTEGRATED CIRCUITS**

**Character Generators**

74S 262	£13.70		
2513 (U)	£6.50		
2513 (L)	£6.50		
MCM 6571P	£6.71	6402	£4.50
9368 (7 segment display decoder)	£2.45	AY-5-1013	£4.50

plus 8% VAT

**UARTS**

**Send for New Hardware Catalogue & booklist**

**DEVLIN MODULAR 60 KEY KEYBOARD**

Pet replacement

Mounted on PCB  
X-Y matrix £38.50  
Matching Hex keypad £7.20

Send for details

**GAMES BOOKS**

101 Basic Computer Games	D. AHL	£6.50
Star Ship Simulation		£5.10
Game Playing with Computers		£10.20
Game Playing with Basic	D. Spencer	£4.20
SARGON-A Chess Computer Program in Z80		
ASSEMBLY LANGUAGE		£9.50

**PASCAL BOOKS**

Pascal: User Manual & Report	Springer-Verlag	£5.52
Problem Solving Using Pascal	Springer-Verlag	£7.84
Programming in Pascal	P. Grogono	£7.50
A Practical Introduction to Pascal	A. Addyman	£3.50

**PRACTICAL APPLICATION BOOKS**

Programming the 6502 (SYBEX)	£8.00
The 6800 Microprocessor	£3.60
8080A BUGBOOK	£6.95
Data Acquisition Handbook	£2.00
77-68 Construction Manual	£7.50
Fundamentals of Digital Computers	D. Spencer £7.50
National Semiconductors Interface Circuits Data Book	£2.75
Programming a Micro 6502	C.C.Foster £7.95
Semiconductor Circuit Design Vol 1	T.I £6.50
Semiconductor Circuit Design Vol 2	T.I £6.50
Semiconductor Circuit Design Vol 3	T.I £6.50
Semiconductor Circuit Design Vol 4	T.I £6.50
Semiconductor Circuit Design Vol 5	T.I £7.95

**TERMS AND CONDITIONS**

Minimum official order £10.00  
Postage & packing 30p on Hardware  
Hardware price plus 8% VAT.  
Callers welcome Mon-Sat 9.00-5.30  
but please phone us first on 0635 30505.

Barclaycard & Access Welcome

ALL MAIL ORDER TO NEWBURY

**INTRODUCTORY OFFER**  
**MODEL 700 VDU**

- Assembled and tested
- 64 characters x 16 lines
- Upper case only
- 110-1200 baud

**£299 with video monitor**

**Newbear Computing Ltd.,**  
**40 Bartholomew St, Newbury, Berks.**  
**0635 30505**

**Visit our Northern office at 2A**  
**Gatley Rd, Cheadle, Cheshire.**  
**Tel 061-491-2290**





# Beginner's Gambit

## NOTES ON "32"~

### A Version of Chess

R. A. Diamond, *Tottenham College of Technology, London.*

Many amateur programmers will have attempted to write a program that plays chess but will have been defeated by the complexity of the rules. Those who pass this stage may well be daunted by the task of programming a strategy that plays useful chess. These notes may encourage people to deal with the former problem whilst avoiding the latter. The suggestion is to write a program that plays a version of chess called "32" in which any piece taken is replaced on the board by its captor.

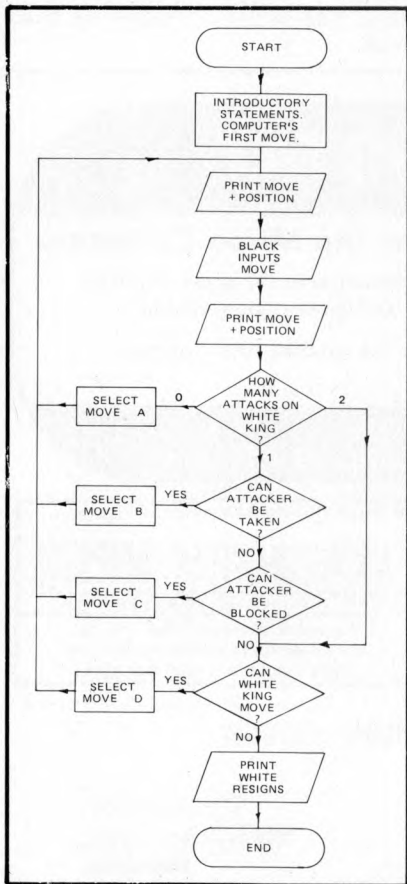

#### The Game Strategy

The strategy for playing a good game of 32 involves restricting the scope of opposition pieces, and this usually involves tucking away taken

major pieces on the back rank or taken pawns on the next rank. Generally it is a relatively simple matter to program this. Equally well, a human opponent unless experienced in this version of chess, will find it somewhat difficult to adjust to the fact that material loss cannot arise and a more even game ensues.

Suppose we decide to play 32 according to the simplified rules

1. Any piece taken must be replaced on the board.
2. Check cannot be blocked by using an opponent's piece.
3. No castling or en passant are allowed.
4. Pawns remain pawns and cannot be put on the back rank.
5. Otherwise according to normal chess rules.

Suppose further we label the board as shown and allocate values to pieces as shown.

WHITE : COMPUTER

11	12	13	14	15	16	17	18
21	22	23	24	25	26	27	28
31	32	33	34	35	36	37	38
41	42	43	44	45	46	47	48
51	52	53	54	55	56	57	58
61	62	63	64	65	66	67	68
71	72	73	74	75	76	77	78
81	82	83	84	85	86	87	88

BLACK : PLAYER

	PAWN	KNIGHT	BISHOP	ROOK	QUEEN	KING
WHITE	1	2	3	4	5	6
BLACK	-1	-2	-3	-4	-5	-6

#### Piece Values

Let the current position be contained in array P and the current position of the white king be K. Thus initially  $P(83) = -3$ ,  $P(17) = 2$ ,  $K = 14$  etc. Sections of the program involving printing instructions, the current position and move are straightforward as are the initial move (or opening lines if required) and the arrangements for black to input his response. A 6 figure move, e.g. 614317, could be used for: the piece on square 61 takes the piece on square 43 and puts it on square 17; whereas 614300 would mean: the piece on square 61 moves to square 43.

#### The flowchart

Bearing in mind that if white is in check then he has to do something about it, an outline flowchart (disregarding offers/acceptances of draws and black's resignation — which are easily catered for) might be designed as shown.

To implement this flowchart perhaps the major subroutine specification will be : given a chess position defined by array Z and a target square S, find the number of attacks on square S and record the positions and types of attack. If we use subscripts of array J to record the positions of attacking pieces and corresponding contents to record types of attacking pieces then part of the subroutine written in BASIC might appear as:

```

100 REM; 110 - 140 DEALS WITH
    PAWN ATTACKS ON SQUARE S
110 IF Z(S+9) = -1 THEN J(S+9)
    = -1
120 IF Z(S+11) = -1 THEN J(S+11)
    = -1
130 IF Z(S-9) = 1 THEN J(S-9) = 1
140 IF Z(S-11) = 1 THEN J(S-11)
    = 1
.....
300 REM; 310 - 350 DEALS WITH
    QUEEN/ROOK ATTACKS
    FROM THE LEFT OFS
310 FOR P = S - 1 TO 10* INT(S/10)
    + 1 STEP - 1
320 IF ABS(Z(P)) = 4 THEN J(P) =
    Z(P) \ GOTO 360
330 IF ABS(Z(P)) = 5 THEN J(P) =
    Z(P) \ GOTO 360
340 IF ABS(Z(P)) > 0 THEN 360
350 NEXT P
360
    
```

Note that 340 deals with the line of action being blocked. In 300 - 350 we are searching for attacks on square S by queens and rooks from the left of S on the diagrammed board. Starting from square S we go across the board to the left. If we meet queen or rook we record it and

jump out of this section. If we meet any other piece we jump directly out of this section. Towards the end of the subroutine we can split array J to count and find black and white attacks on square S separately.

This subroutine can be used for example to find out if white is in check by

```
50 MAT Z = P \ S = K GOSUB 100
```

**Punishing the offender**

Suppose now that white is in single check. Can the offending black piece be taken? Again we use the same subroutine to see if the square from which check is given is attacked by a white piece or pieces. But we must be careful to make sure that white can indeed take the attacking piece without revealing a discovered check on himself. So once again we use the same subroutine for the position that would arise if white takes the black checking piece to see whether the white king is still under attack.

Suppose we have now gathered all the moves that can take the checking piece; it remains to decide which one to choose. This could be done on a random basis or in order of priority pawn, knight, bishop, queen and king. The taken piece could be placed on the highest numbered free

square (provided it doesn't check white) or if a pawn is being taken, replace it on the highest numbered free square less than 79 (again provided it doesn't check white).

Similarly, to block a check, a subroutine can be used to store in an array all squares intermediate between U and V. Whether a square X can be reached by a white pawn depends on whether  $P(X - 10) = 1$  or in some cases whether  $P(X - 20) = 1$  and  $P(X - 10) = 0$ ; and in all cases that the new position is free from white being in check. Whether a square X can be reached by a white piece other than a pawn can be established using the major subroutine referred to earlier. The decision of which block to choose could be random or pawns first etc.

**The fugitive**

Suppose on the other hand we cannot take the checking piece or interpose a piece (as occurs in all examples of double check) then we will be looking for escape squares for the white king. Free squares adjacent to the white king are easily found and the main subroutine can check that they are not also under attack.

Alternatively when under attack all possible moves corresponding to selection boxes B, C, D on the flowchart can be gathered and some other criterion for choice can be used.

**A Moving Opportunity**

We are now left with the case of the white king not being under attack. That is the selection box A on the flowchart. How do we decide on our move? In normal chess a program that's going to play even at club standard has to come up with a very good answer to that question but in 32 *this is not so*. One can frustrate the opposition by quite simple strategies occupying up to 20% of the total program. Even a fairly transparent policy such as take and replace a piece with one of the knights; advance a piece on a random (or weighted random) basis etc., can be difficult to combat and heavy use of the major subroutine facilitates programming.

It is easy to incorporate an illegal move finder after black inputs his move. The framework described is amenable to further development to include a more positive strategy for white rather than the spoiling tactics referred to.

Even in a simple form the program leads to bizarre and brightly entertaining positions and it is a routine matter to print out the final position and a record of the game. If anyone knows an infallible strategy for winning 32 I shall be delighted to hear from him or her . . . meantime good luck.

**LOOK IN**

ANNOUNCING THE NEW

**μHEX EPROM PROGRAMMER**

PUSH BUTTON SWITCHING FOR 2704, 2708 and 2716

Needs only standard CPU power supplies. Has on-board stabilised 26v inverter.

PERFECT FOR Nascom, Micros, etc. or any PIO equipped CPU.

Tested and approved by NASCOM



Includes Z80, 8080, and 6800 control programs.

Features zero force Eprom socket.



**ONLY £65 inclusive**  
Early orders ex stock s.a.e. for details

**MICRO HEX COMPUTERS**  
2 Studley Rise, Trowbridge, Wilts.

BOUGHT AND SOLD: APPLE II  
Promglow Ltd.  
Tel: 01-368 9002

**COMPUSTAT**

**Continuous Stationery for the Micro Computer**

All sizes of listing paper stocked. Specialists in the preparation of Printed Continuous Stationery - Design Service available -

Listing paper & OTC Stocked for the Anadex (9 1/2") printer.

Phone or write for a quotation to Miss Allen

**01-520 6038**  
**63 ORFORD ROAD, LONDON, E17 9NJ.**

**NEW NASCRUNCH**

+, -, x, ÷, Sin, Log, x<sup>2</sup>, x, Cos, Tan, etc.

**LOW COST SYSTEM TO PROVIDE POWERFUL CALCULATOR FUNCTIONS ON BASIC NASCOM-1**  
Complete Hardware/Software Package

**Hardware** MMS7109 peripheral providing full calculator functions (reverse Polish notation)

**Software** 1. Ordinary Scientific Calculator  
2. Interface to machine code  
3. Easy to use interpreter

Ideal upgrade at full cost to increase the power of the NASCOM-1 via a simple-to-use interface. Hobbyist and process control applications. Software included on cassette + complete instructions. Complete kit **£38.50**

inc. VAT & p.p.

(Cheque with order) For full information send SAE

**MICROCOSM, Tower Hill Cottage, Rainon, Cheshire, SK10 5TK**  
Tel: 061 436 4727 (evenings)

THE JOURNAL OF THE MICROCOMPUTER INVESTORS ASSOCIATION

**THE MICROCOMPUTER INVESTOR**

INVESTORS WHO USE MICROCOMPUTERS

FOR AN INFORMATION PACKET, SEND 1.00 TO:  
MCA, 902 ANDERSON DR., FREDERICKSBURG, VA 22401

BACK ISSUES ARE NOW AVAILABLE

**MIKE DENNIS**

"Blackberries",  
Sheriff's Lench,  
Evesham,  
Worcs,  
WR11 5SA.  
tel - 0386 870891

Hardware & software consultant  
Training courses



# Pet Preening PLAY SNAP WITH YOUR PET

Rupert Steele, St. John's College, Oxford.

This is essentially a reaction tester: the SNAP format is simply to make the game more interesting, particularly for younger users. There are ten levels of difficulty from 1 (trivial) to 10 (impossible); I draw with the machine on 5.

The program monitors the keyboard with a GET instruction and times the response. If the response is faster than the loop in lines 320-330 a point is awarded to the human, and if slower the computer takes a point. If the user presses a key when there is no 'snap' he is penalised two points.

**Notes:**

At present, there are six possible digits shown, but line 300 may be altered to give more or less.

Line 290: the string is "< clear screens > 14 x cursor down > < 15 x Cursor Right > ". The printer does not print these characters.

Line 400: the string is "< 6 x Cursor left > ".

The program will run with only minor changes (lines 290, 400 and 260-270) on any micro running 8k Microsoft BASIC or similar, if GET is supported. TI\$ is the time string on the PET.

Sometimes, the computer will appear not to print the next digit; this is when the new one is identical with the old; this is a small trick as the player is put off and unsure which digit to watch.

```

100 REM ** REAL TIME SNAP **
110 REM RUPERT STEELE 28-NOV-78
115 DIM C(2)
118 PRINT"DO YOU KNOW THE RULES";
120 INPUT N$:N$=LEFT$(N$,1)
130 IF N$="Y" THEN 200
140 PRINT"THE OBJECT OF THE GAME IS TO BEAT THE"
150 PRINT"COMPUTER AT SNAP. THE COMPUTER PRINTS"
160 PRINT"TWO DIGITS NEXT TO EACH OTHER ON THE"
170 PRINT"SCREEN; IF THEY MATCH THERE IS A SNAP"
180 PRINT"IF YOU PRESS ANY KEY FAST ENOUGH, YOU"
190 PRINT"WIN THE SNAP, OTHERWISE I WIN"
192 PRINT"TYPING ! WHEN THERE IS NO SNAP TERM-"
194 PRINT"INATES THE GAME":PRINT
195 REM ** RANDOMISE **
200 PRINT"PLEASE GIVE A NUMBER BETWEEN 20 AND 100"
210 INPUT A:IF A>100 OR A<20 THEN 200
220 FOR N=1 TO A: B=RND(1): NEXT N
230 PRINT"LEVEL OF DIFFICULTY (1 EASY 10 HARD)"
240 INPUT D:IF D<1 OR D>10 THEN 230
243 REM ** INITIALISATION **
245 Y=0:M=0
250 PRINT"YOUR SCORE:"Y" MY SCORE:"M
251 C(2)=0:P=1
252 FOR A=1 TO 2
260 Z$=TI$
270 IF Z$=TI$ THEN 270
280 NEXT A
285 GET L$
286 IF L$<>" THEN 285
290 PRINT"";
300 C(P)=INT(6*RND(1)+1)
310 PRINTC(P);
320 FOR L=1 TO 130+450/D
330 NEXT L
340 IF C(1)=C(2) THEN 420
345 N=150+INT(RND(1)*400)-300/D
350 FOR L=1 TO N:NEXT L
360 GET L$:IF L$="" THEN 390
365 IF L$="!" THEN 470
370 PRINT:PRINT"CHEAT! 2 POINTS TO ME"
380 M=M+2:GOTO 250
390 P=P+1:IF P=2 THEN 300
400 P=1:PRINT"";
410 GOTO 300
420 GET L$:IF L$="" THEN 450
430 PRINT:PRINT"SNAP! WELL DONE, 1 POINT TO YOU"
440 Y=Y+1:GOTO 250
450 PRINT:PRINT"SNAP! BAD LUCK, I WAS FIRST, 1 TO ME"
460 M=M+1:GOTO 250
470 PRINT:PRINT"YOUR SCORE:"Y" MY SCORE:"M
475 IF M=0 AND N=0 THEN 490
480 PRINT"YOUR PERCENTAGE SCORE:"100*Y/(M*Y)
490 PRINT:PRINT"REPLAY":INPUT N$:N$=LEFT$(N$,1)
500 IF N$="Y" THEN 230
510 PRINT"THANKS FOR THE GAME"
    
```

## LOOK IN

### TRS-80 SOFTWARE

WE HAVE THE LARGEST TRS-80 PROGRAM LIBRARY IN THE COUNTRY. BUSINESS, FINANCE, SCIENTIFIC AND GAMES. LEV 1, LEV II AND DISK. NEW PROGRAMS DAILY. WE PAY GOOD PRICES FOR ORIGINAL PROGRAMS.

**SOME EXAMPLES**

LIBRARY 100	£37.50
STARTREK 111	£10.50
ELECTRONICS 1	£ 6.50
INVENTORY	£13.50
FINANCE 1	£ 6.50
ASTRONOMY 1	£ 6.50

**MICROCOMPUTER APPLICATIONS,  
11, RIVERSIDE COURT,  
CAVERSHAM, READING RG4 8AL**

**BASIC PROGRAMS ON CASSETTE  
FOR PET, TRS-80 LEVEL 2**

Business Accounts, Ledger, Payroll, Inventory, V.A.T. at £9.95 each. S.A.E. for price list.

**R. JACQUES**

16 Market Place, Hexham,  
Northumberland NE46 1XQ  
Tel: 3423

**380Z SOFTWARE**

BASIC programs guaranteed for 6 months, Using BASG, BASGF, BASGP, BASGC Cassette, listing or paper tape (no parity) supplied.

**16K programs**

**£8 STARTREK** destroy the Klingons in your allotted time.

**£5 PONTOON** allows doubling, splitting of pairs, five card tricks.

**£5 POKER** bluffs very well.

**£4 ROULETTE** allows any number of players.

**£5 MASTERMIND 1** you guess the computer's code. Variable 1-30 columns

**£4 MASTERMIND 2** guess the computer's code before it guesses yours. Restricted to 5 columns only with no repeated digits.

**£4 KING** rule a country for 8 years managing the economy.

**£3 DARTS** Darts training program. Computer is a dummy opponent. You will still need a dartboard. As published in PCW.

**£3 MOON** land the LEM on the Moon

**£3 POLY. FIT** fits a polynomial of any degree to a set of points.

**£3 SIMULT. EQN.** solves any set of linearly independent equations.

**USING THE 380Z's GRAPHICS**

**£8 ROBOT CHASE** On a par with Startrek as an addictive game. Requires skill. Gives a rating depending on your ability.

**£4 HANGMAN** Yes, boring old hangman with over 200 words, expandable.

**£6 PLOT** will plot any function in polar, parametric or cartesian form. Superb mathematical tool. Fascinating to watch.

**£3 PATTERNS** Suite of demonstration programs. Many good ideas.

**IF YOU HAVE 32K STORE  
then try**

**£10 SUPER STARTREK** with black-holes, computer assisted warping.

**FOR THOSE WITH 32K AND THE  
REAL-TIME CLOCK BOARD  
THERE ARE:-**

**£8 ROBOTS** As for ROBOT CHASE but with an extra real-time option.

**£6 MOON LANDER** Land on any planetary body in real-time.

Both of the above programs need BASIC, which is an interpreter based on BASGF but also allowing BASIC to access the clock, and having a keyboard scanning function similar to PET's GET command. BASGC is supplied free when purchasing both of the above programs, and is **£4** purchase individually.

**DISCOUNT** 10% on two or more items  
20% on five or more items  
30% on ten or more items

All items are post free. Also, written in machine code - MOI Mini Pilot £6

**F DONOVAN**

114, Beech Road, St. Albans,  
Hertfordshire AL3 5AU

# TANDY TRS-80

## The Soft Cursor

M.O. Benjamin

The January issue of PCW contained a very interesting article by P.J. Turner, on the Tandy TRS-80 Level 2.

At the end of his article, Mr. Turner gave the listing for a Cursor Graphics program which I tried out and found to add considerably to the graphics capability of the TRS-80. However, having spent many happy hours drawing fancy pictures, I realised the need for a method of storing the pictures on tape, so I set to, to extend Mr. Turner's program, and in the process added several other facilities as well.

The added facilities are as follows: Save/retrieve picture on tape, change from continuous line drawing/cursor movement to single block drawing & vice versa, mix alphanumeric characters on screen with the graphics.

One or two notes on the program itself: to save a picture on tape, simply press the 'M' key, but ensure the tape recorder is set to record first. The picture is stored on tape in blocks of ten screen memory locations, blank areas of the screen being ignored, so the tape will start and stop as the computer reads past blank screen areas. When all the screen has been read, the screen will clear and

"DATA DUMP COMPLETE" will appear. This is simply to let you know when it has finished recording. To retrieve the picture from tape, just follow the screen instructions when the program is run.

With regard to the TRS-80 Level two, I purchased my system last July, opting for the Level 2 from the outset. I had no previous programming experience (apart from a Casio

calculator), but from all the articles I had read, I realised that the Level 2 was far better than the Level 1. Tandy's instruction manual is so good that I was able to learn very easily, and I cannot recommend the Tandy highly enough. The instruction manual is really excellent, and very clear, although the Level 2 manual assumes one already has some knowledge of Basic, so I also purchased the Level 1 Manual, which gives a very simple and easily understood introduction to the Basic language.

There has been some criticism concerning difficulty in setting the cassette volume levels with the TRS-80, and I think this should be clarified. The difficulty only arises on the initial setting up of the recorder, and once the correct level has been found, no further trouble occurs. I control three recorders with my system (2 cassette, and 1 Reel recorder), and have had absolutely no problems

## LOOK IN

### MICROCOMPUTER HIRE

Pet, Apple II, Horizon, Nascom, Motorola 6800 & others.

### PROMGLOW LTD.

Telephone: 01-368 9002

### NORTH STAR COMPATIBLE SOFTWARE

#### INFORMATION UNLIMITED

WHATSIT Data Base Management System can support a disc-resident data base and process enquiries (as well as updates) in a real-time conversational mode **£55.00**

#### MICROSOFT

FORTAN-80 — ANSI '66 (except for COMPLEX) plus many extensions. Includes relocatable object compiler, linking loader, library and manager, Z80 assembler and cross reference list utilities **£245.00**

Disk Extended BASIC — New version, ANSI compatible with long variable names, WHILE/WEND, chaining **£175.00**

#### ORGANIC SOFTWARE

TEXTWRITER II affords complete word processing capability for North Star systems under the CP/M Operating System **£59.00**

The above software is supplied on 5.25" diskettes. Prices are exclusive of VAT @ 8% and postage & packing (add 75p). Please send large SAE for details.

INTERAM Computer Systems Ltd.  
59 Moreton St. Victoria, London SW1

01-834 0261/2733

**INTERAM**

Miles Gregory Top Quality  
SHORT LENGTH BLANK

## CASSETTES

C.7 36p C.12 38p C.17 39p

All other lengths and makes available. Post free orders over £5 otherwise 20p per order.

METROTAPES LTD. (Dpt. PCW),  
244 Edgware Road, London, W2 1DS  
Tel: 01-724 1673.

Callers welcome.

### ENGRAVED SIGNS, PANELS AND LABELS

Front engraving on laminates, reverse on perspex. Switches & Panel lights engraved. One-offs or mass production. Send for leaflet.

I.C.E.C., 22 Station Road,  
Carlton, Nottingham.

### EPROM ERASER

New Compact low-cost British design. Erases up to 32 devices in 30 mins. **£34.95 inclusive**

### TEX MICROSYSTEMS

126 New House Park, St. Albans,  
Herts AL1 1UP

### MICROSTAR 45 PLUS

Multi-user, twin floppy disc system with Stock Control, Sales Ledger, Word Processing and Mailing List Program Packages. 64K RAM, 1.2 or 2.4m char disc storage extendable to 4.8m. Price from **£4,950**. Complete systems from **£7000**.

### PRODUCTIVITY UNLIMITED

Telephone Gerrards Cross 83626  
Telex 847777 DELRAY G attn.  
MANCON

### SORCERER'S APPRENTICE

Cassette of programs illustrating clearly the use of all BASIC instructions. Special Price **£5**.

Software: Please send SAE for list.

Programs: All types wanted urgently. Top prices paid.

MICROPUTE, 9 Lark Hall Crescent,  
Macclesfield, Cheshire SK10 1QU

### NASCOM DIS-ASSEMBLERS!

- As per PARKINSON'S DIS-ASSEMBLER in MAY, PCW.
- Fully coded with source documentation for Nascoms with T2, B-BUG, DJBUG and soon T4.
- Now 2 versions REVAS and REVAS-C!
- REVAS executes as a simple command, and decodes any Z-80 program in memory to assembler mnemonics.

**£4.50 + 50p p.p.** on cassette

Fully relocatable

**£22.50 + 50p p.p.** on 2 x 2708 Eproms (F000-F7FF)

- REVAS-C interacts with user to give labelled listings with cross-reference table, and has output to tape facility.

**£6.00 + 50p p.p.** on cassette

Fully relocatable

**£32.00 + 50p p.p.** on 3 x 2708 Eproms (F000-FBFF)

Cassette recorded to NASCOM, CUTS 300 or 1200. Specify which.

### D J SOFTWARE

16 Cuckfield Avenue  
Ipswich, Suffolk IP3 8RZ

Consultant: D. Johnson, B.Sc, M.Sc

whatsoever. I feel that this has been exaggerated in many reviews, as, once set up, the tape system is extremely reliable.

The only other major criticism, (with which I agree) is the modular design. I was not too happy with the

separate items all connected with a mass of cables. I overcame this problem by constructing a new cabinet to hold the entire system as one unit (photo above), with sufficient room for further expansion.

To sum up, I think the Tandy is

excellent value for money, extremely well thought out, and with a very powerful Basic, and apart from criticism concerning the modular construction, is to my mind the best buy within the £500-£1000 price range.

**EXTENDED CURSOR GRAPHICS**

```

1  CLS: CLEAR100
2  ?: "THIS PROGRAM ALLOWS YOU TO DRAW ANY
   PICTURE ON THE SCREEN AND SAVE THE PICTURE
   ON TAPE IF DESIRED": ? STRING $ (64, "#")
3  ? "THE CONTROL KEYS ARE . . . : V = SINGLE BLOCK
   DRAWING ↓ "TAB (28) " B = CONTINUOUS LINE
   DRAWING ↓ "TAB (28) "M = SAVE PICTURE ON
   TAPE ↓ "TAB (28) "C = CLEAR SCREEN"
4  ? "THE DRAWING KEYS ARE . . . : ↓ ↓ U = UP : D =
   DOWN : R = RIGHT : L = LEFT ↓ ↓ CURSOR MOVE-
   MENT (NON DRAWING) ↓ W = UP : Z = DOWN : F =
   RIGHT : A = LEFT : P = PRINT (CHARACTERS): @ =
   RETURN TO GRAPHICS":?
6  INPUT "ENTER TO START":W:CLS:?:INPUT "DRAW
   PICTURE. . 1 : RETRIEVE FROM TAPE . . 2":N:CLS:
   ON N GOTO 8,3000
8  ? : ? : ? "BEFORE STARTING YOUR DRAWING, ↓ - -
   IT SHOULD BE NOTED THAT WHEN SAVING THE
   DRAWING ON TAPE, THE TAPE WILL STOP FOR
   SHORT PERIODS WHILST THE COMPUTER COUNTS
   PAST BLANK PORTIONS OF THE SCREEN, THIS IS
   TO AVOID TAPE":
9  ? " WASTAGE ANDTIME. WHEN THE ENTIRE SCREEN
   HAS BEEN CHECKED, THE COMPUTER WILLPRINT
   . . . ** DATA DUMP COMPLETE ***": STRING$ (64,
   "-")
10 X=1:Y=1:INPUT "SELECT TYPE OF CURSOR MOVE-
   MENT REQUIRED AT START ↓ "TAB(7) "SINGLE
   BLOCK. . 1 : LINE. . 2": V:CLS
    
```

```

20  B$ = INKEY $ ; IFB$ = "M" THEN2000
21  IFV = 1THEN23ELSE25
23  IFB$ < > " " THENA$ = B$
24  GOTO30
25  IFB$ = < > " " THENA$ = B$
30  IFA$ = "L" THENX = X-1:GOSUB1000
31  IFA$ = "V" THENV = 1:GOTO20
32  IFA$ = "B" THENV = 2:GOTO20
35  IFA$ = "A" THENRESET (X,Y):X=X-1
36  IFA$ = "P" THEN3090
37  IFX < 0THEN X = 0
40  IFA$ = "R" THENX = X+1:GOSUB1000
45  IFA$ = "F" THENRESET (X,Y):X=X+1
47  IFX > 127 THEN X = 127
50  IFA$ = "D" THENY = Y+1:GOSUB1000
55  IFA$ = "Z" THENRESET (X,Y):Y=Y+1
57  IFY > 47 THEN Y = 47
58  IFA$ = "C" THENCLS
60  IFA$ = "U" THENY = Y-1:GOSUB1000
65  IFA$ = "W" THENRESET (X,Y):Y=Y-1
67  IFY < 0 THEN Y = 0
68  P=POINT (X,Y)
69  SET (X,Y):FORF=1TO30:NEXT:RESET (X,Y):IFP=1
   THENSET (X,Y)
70  GOTO20
1000 IFX < 0THENX=0:RETURN
1001 IFY < 0THENY=0:RETURN
1002 IFX > 127THENX=127:RETURN
1003 IFY > 47THENY=47:RETURN
1010 SET (X,Y): RETURN
    
```

**LOOK IN**

**DIRECT FROM U.S.A.**

We import direct and save you money. Try our Challenger IP with Basic and graphics for only £320, or AIM65 for only £220. Complete S100 business systems from £1500.

**INTELLIGENT ARTEFACTS LTD.**  
Cambridge. Telephone 022 020 689

**HIRE A PET MICRO!  
WHY NOT TRY IT  
BEFORE YOU BUY IT**

£5 per day or £25 per week

**Essex Computer Services**

Tel: Canvey Island 61663 or 61926

**WE DO MORE THAN JUST SUPPLY**

The new Version of the

**ITT 20-20 MINI-COMPUTER**

We are Computer System Specialists and provide, with confidence:

- System Interface
- Expert Advice on System Improvement
- Software to Specific Requirements
- Immediate Response to Technical Enquiries
- Numerous Programmes always available (Commercial, Scientific, Educational & Games).

**COURTESY SOFTWARE LTD.,**  
4 Woodhall House, Cole Green Lane,  
Welwyn Garden City, AL7 3PW.  
Tel: W.G.C. (07073) 32544

**NASCOM USERS**

Opto-isolated inputs and relay outputs!  
Card with 4 off each **£30.00 built**  
Nascom build service **from £31.00**  
Auto cassette control board **£5.50 built**  
Add VAT and postage and packing to all prices. SAE for full details. Mail order only.

**WILSON DESIGNS,**

**31 Little Station Street, Walsall,  
West Midlands WS2 9JY.**

**Southampton  
Your PET Dealer**

Free £50 software or accessories from large range of Commodore and Petsoft 8K and 16K versions in stock. Hire available from £20 p.w. (refundable) Technical support and servicing

**13 St. James Road, Shirley,  
Southampton**

**Tel: Southampton (0703) 774023**

**SORCERER SOFTWARE**

Programs to teach you more about Sorcerer's screen-handling and graphics.

**TENNIS**

A standard two bat and ball game

**PLOTTIT**

Plots curves using high resolution (240 x 400) graphics

**£8 each inc. VAT & postage**

**Systems Audit,**

**96 Grimsdyke Road, Hatch End,  
Pinner, Middlesex.**



**TRUMPET, VOLUNTARY**

Responding to TIDBITS information or an advertisement?

Say you saw it in PCW

Blow your own trumpet.

Mention your magazine.



**NASCOM-1 WORKING SYSTEM**

Save VAT: Avoid Bugs as a second user

**HARDWARE: FIRMWARE  
SOFTWARE**

**HARDWARE:** Professional built & tested  
NASCOM & 3A PSU, 2k enhanced  
NASBUG (superfacilities) only **£185.00**  
Buffer + mini-motherboard **£ 35.00**  
8K RAM Board Complete **£ 85.00**  
Joystick (with cassette s/w) **£ 14.00**  
**FIRMWARE:** on 2708 1k EPROM's  
Super Tiny Basic (3k) **£ 33.00**  
REVAS (2k) Z80 disassembler **£ 22.00**

**SOFTWARE CASSETTES: Load & Read**

ZEAD (Z-80 Assembler) **£ 25.00**  
Mol Mini Pilot (Text Language) **£ 4.00**  
Ten games (Othello, Crash, etc.) **£ 5.00**

All paperwork included: UK post free  
No cheque cashed if items sold, SAE if answer required. Cheques to:

**M J JACKSON  
2 VERE GARDENS  
IPSWICH, IP1 4NZ**

**NASCOM OWNERS**

SMART 1 is here.

SMART 1 buffers Nascom

SMART 1 converts to Nasbus

SMART 1 gives you 32k bytes cheap

SMART 1 is cheap

SMART 1 printed circuit board

is only **£28.95 + 50p p/p.**

Fill the holes in SMART 1 with goodies and for a total outlay of approximately **£125** you will have 32K bytes of memory.

Send your order to: **Mike Dennis,  
Blackberries, Sheriffs Lench,  
Evesham, Worcs** or write for more details.

See the design in May PCW

*Note:* the following section saves the picture on tape

```
2000 POKE16382, 43:FORI=15360TO16383:REM prints '+'
      at lower r.h corner to indicate dump in progress
2006 A=PEEK(I)
2007 IF A > 32 AND A < 97 OR A > 128 AND A < 192 THEN
      L=L+1:C(L)=I:D(L)=A:REM counts past blank screen
      locations and records only picture/character blocks
2008 IFL < 10 AND I < 16383 THEN2020
2010 PRINT # -1, C(1), D(1), C(2), D(2), C(3), D(3), C(4),
      D(4), C(5), D(5), C(6), D(6), C(7), D(7), C(8), D(8),
      C(9), D(9), C(10), D(10): L=0:REM dumps in blocks
      of 10 to save tape and time
2020 NEXTI
2040 CLS:PRINT @ 462, "**** DATA DUMP COMPLETE
      ****":END
```

*Note:* following section retrieves picture from tape.

```
3000 CLS:?:?:?"PRESS ENTER WHEN READY ** NOTE
      THAT WHEN PICTURE IS COMPLETE, THERE WILL
      BE A SHORT DELAY BEFORE THE TAPE SWITCHES
      OFF, DUE TO THE COMPUTER CHECKING TO THE
      END OF THE SCREEN. A FLASHING CURSOR WILL
      BE DISPLAYED AT THE LOWER";
3001 ?"RIGHT HAND CORNER WHEN RETRIEVAL IS
      COMPLETE. ADDITIONS OR ALTERATIONS TO THE
      PICTURE MAY THEN BE MADE":?:INPUTW:CLS
3005 FORI=1TO1023STEP10
3010 INPUT# -1, C(1), D(1), C(2), D(2), C(3), D(3), C(4),
      D(4), C(5), D(5), C(6), D(6), C(7), D(7), C(8), D(8),
      C(9), D(9), C(10), D(10):FORJ=1TO10:POKEC(J), D(J):
      NEXTJ:X=PEEK(16382):IFX < > 43THENNEXTI
3030 X=124:Y=46:GOTO20:REM sets cursor to lower r.h
      corner and returns to drawing mode.
```

*Note:* the following section allows characters to be mixed with graphics, commencing from the current graphics cursor position + 1

```
3090 U=INT (Y/3) *64+INT (X/2) +1
3095 PRINT @ U, " ";
4000 B$=INKEY$:IFB$="" THEN N4020E LSEPRINT B$;
```

```
4010 GOTO4000
4020 A$="" :GOTO20
```

Summary of control keys

#### KEY FUNCTION

C	Clear Screen
V	Convert to single block drawing
B	Convert to continuous (rpt) line drawing
P	Convert to character printing (commences from current graphics cursor position +1
@	Revert to graphics
M	Save picture on tape. (ensure recorder is ready & in record mode before pressing 'M' key)

#### DRAWING KEYS

R	Draw RIGHT
L	Draw LEFT
U	Draw UPwards
D	Draw DOWNwards

#### CURSOR CONTROL KEYS

W	Move cursor UP
Z	Move cursor DOWN
A	Move cursor LEFT
F	Move cursor RIGHT

*N.B.* Moving the cursor over a lit block, will delete that block.

In the Character printing mode, the key works as normal. To print characters on more than one line, press key at end of the first line, cursor will then be displayed, then move cursor to start of new line and press P key, the next line can then be typed.

When using the continuous line drawing mode, pressing the space bar (or any non-control key) will stop the cursor at its present position until the next control key is pressed.

In the Character printing mode, the SHIFT ↓ will move the print position down one line without returning to the start of line, and the SHIFT ↑ will move the print position UP one line.

# Need A Scientific Computer ?

## then you need a VECTOR GRAPHIC MZ from ALMARC

why?

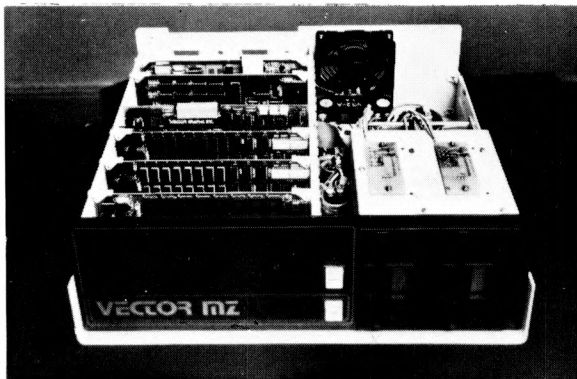

Vector Graphics MK & 82K of RAM + two 315K BYTE Disk Drives.

**CP/M\*** Software on the MZ  
**CBASIC** Compiled basic  
**COBOL** Subset of ANSI  
**FORTRAN** Runs in 24K; also has an assembler and a linker.  
**Plus** Macro assemblers, linkers, text editors etc.

- **BECAUSE**  
The MZ uses a fast 4 MHz Z80A processor.
- **BECAUSE**  
The MZ uses the S-100 bus.
- **BECAUSE**  
At £2300.00 the MZ gives you more bytes for your money. Discounts are available too.
- **BECAUSE**  
Almarc give you complete systems. For example "OPT", our own graphics package, has been designed to reside at the end of Basic and works with the HIGH RESOLUTION GRAPHICS BOARD. OPT provides for point, line and shape plotting, and also has an alpha-numeric character generator. All mathematical functions are completely independent of the DOS.
- **BECAUSE**  
Almarc offers a complete range of system software. As well as MDOS, MBASIC, and a Z80 Assembler supplied with the system, CP/M\* is also available. Check the list opposite for details.

\*Trademark of Digital Research.

*the Almarc of quality*

ALMARC DATA SYSTEMS LTD.  
 29 Chesterfield Drive, Burton Joyce, Nottingham. Tel: 0602 248565

DIODES/ZENERS			
QTY.			
1N914	100v	10mA	.05
1N4005	600v	1A	.08
1N4007	1000v	1A	.15
1N4148	75v	10mA	.05
1N4733	5.1v	1 W Zener	.25
1N4749	24v	1W	.25
1N753A	6.2v	500 mW Zener	.25
1N758A	10v	"	.25
1N759A	12v	"	.25
1N5243	13v	"	.25
1N5244B	14v	"	.25
1N5245B	15v	"	.25
1N5349	12v	3W	.25

SOCKETS/BRIDGES			
QTY.			
8-pin	pcb	.16 ww	.35
14-pin	pcb	.20 ww	.40
16-pin	pcb	.25 ww	.45
18-pin	pcb	.30 ww	.95
20-pin	pcb	.35 ww	1.05
22-pin	pcb	.40 ww	1.15
24-pin	pcb	.45 ww	1.25
28-pin	pcb	.50 ww	1.35
40-pin	pcb	.55 ww	1.45
Molex pins	.01	To-3 Sockets	.35
2 Amp Bridge		100-prv	.95
25 Amp Bridge		200-prv	1.50

TRANSISTORS, LEADS, etc.			
QTY.			
2N2222M	(2N2222 Plastic .10)		.15
2N2222A			.19
2N2907A	PNP		.19
2N3906	PNP (Plastic)		.19
2N3904	NPN (Plastic)		.19
2N3054	NPN		.55
2N3055	NPN 15A 60v		.60
T1P125	PNP Darlington		1.95
LED Green,	Red, Clear, Yellow		.19
D.L.747	7 seg 5/8" High com-anode		1.95
MAN72	7 seg com-anode (Red)		1.25
MAN3610	7 seg com-anode (Orange)		1.25
MAN82A	7 seg com-anode (Yellow)		1.25
MAN74	7 seg com-cathode (Red)		1.50
FND359	7 seg com-cathode (Red)		1.25

9000 SERIES			
QTY.		QTY.	
9301	.85	9322	.65
9309	.50	9601	.30
		9602	.45

C MOS							
QTY.		QTY.		QTY.		QTY.	
4000	.15	4017	.75	4034	2.45	4069/74C04	.45
4001	.20	4018	.75	4035	.75	4071	.25
4002	.25	4019	.35	4037	1.80	4081	.30
4004	3.95	4020	.85	4040	.75	4082	.30
4006	.95	4021	.75	4041	.69	4507	.95
4007	.25	4022	.75	4042	.65	4511	.95
4008	.75	4023	.25	4043	.50	4512	1.50
4009	.35	4024	.75	4044	.65	4515	2.95
4010	.35	4025	.25	4046	1.25	4519	.85
4011	.30	4026	1.95	4047	2.50	4522	1.10
4012	.25	4027	.35	4048	1.25	4526	.95
4013	.40	4028	.75	4049	.65	4528	1.10
4014	.75	4029	1.15	4050	.45	4529	.95
4015	.75	4030	.30	4052	.75	MC14409	14.50
4016	.35	4033	1.50	4053	.95	MC14419	4.85
				4066	.75	74C151	2.50

CABLE ADDRESS: ICUSD

Telex #697-827 ICUSD SDG

HOURS: 9 A.M. - 6 P.M. MON. thru SUN.

## INTEGRATED CIRCUITS UNLIMITED

7889 Clairemont Mesa Blvd. • San Diego, California 92111 U.S.A.  
NO MINIMUM

COMMERCIAL AND MANUFACTURING ACCOUNTS INVITED  
ALL PRICES IN U.S. DOLLARS. PLEASE ADD POSTAGE TO COVER METHOD OF SHIPPING.  
ORDERS OVER \$100 (U.S.) WILL BE SHIPPED AIR NO CHARGE.

PAYMENT SUBMITTED WITH ORDER SHOULD BE IN U.S. DOLLARS.  
ALL IC'S PRIME/GUARANTEED ALL ORDERS SHIPPED SAME DAY RECEIVED.  
CREDIT CARDS ACCEPTED:

Phone (714) 278-4394 BarclayCard / Access / American Express / BankAmericard / Visa / MasterCard

### MICRO's, RAMS, CPU's, E-PROMS

QTY.		QTY.	
8T13	2.50	7492	.45
8T23	2.50	7493	.35
8T24	3.00	7494	.75
8T97	1.75	7495	.60
74S188	3.00	7496	.80
1488	1.25	74100	1.15
1489	1.25	74107	.35
1702A	4.50	74121	.35
AM 9050	4.00	74122	.55
ICM 7207	6.95	74123	.55
ICM 7208	13.95	74125	.45
MPS 6520	10.00	74126	.45
MM 5314	4.00	74132	.75
MM 5316	4.50	74141	.90
MM 5387	3.50	74150	.85
MM 5369	2.95	74151	.95
TR 1602B	3.95	74153	.95
UPD 414	4.95	74154	1.15
Z 80 A	22.50	74156	.70
Z 80	17.50	74157	.65
Z 80 P10	10.50	74161/9316	.75
2102	1.45	74163	.85
2102L	1.75	74164	.75
2107B-4	4.95	74165	1.10
2114	9.50	74166	1.75
2513	6.25	74175	.90
2708	11.50	74176	.95
2716 D.S.	34.00	74177	1.10
2716 (5v)	69.00	74180	.95
2758 (5v)	26.95	74181	2.25
3242	10.50	74182	.75
4116	11.50	74189	1.25
6800	13.95	74190	1.25
6850	7.95	74191	1.25
8080	7.50	74192	.75
8085	22.50	74193	.85
8212	2.75	74194	.95
8214	4.95	74195	.95
8216	3.50	74196	.95
8224	4.25	74198	1.45
8228	6.00	74221	1.50
8251	7.50	74298	1.50
8253	18.50	74367	1.35
8255	8.50	745491	.65
TMS 4044	9.95	75492	.65

- T T L -							
QTY.		QTY.		QTY.		QTY.	
7400	.20	7420	.25	74H20	.25	74LS76	.70
7401	.20	7421	.25	74H21	.25	74LS86	.95
7402	.20	7422	.40	74H22	.40	74LS90	.85
7403	.20	7423	.30	74H30	.30	74LS93	.85
7404	.20	7424	.35	74H40	.35	74LS96	2.00
7405	.35	7425	.40	74H50	.30	74LS107	.90
7406	.25	7426	.45	74H51	.30	74LS109	1.50
7407	.55	7427	.55	74H52	.20	74LS123	1.95
7408	.20	7428	.55	74H53	.25	74LS138	2.00
7409	.25	7429	.55	74H55	.25	74LS151	.95
7410	.20	7430	.45	74H72	.35	74LS153	1.15
7411	.25	7431	.45	74H74	.35	74LS157	1.15
7412	.25	7432	.75	74H101	.95	74LS160	1.15
7413	.45	7433	.90	74H103	.55	74LS164	2.90
7414	.75	7434	.85	74H106	1.15	74LS193	2.00
7416	.25	7435	.95	74L00	.30	74LS195	1.15
7417	.40	7436	.95	74L02	.30	74LS244	2.90
7420	.25	7437	1.15	74L03	.35	74LS259	1.50
7426	.25	7438	.70	74L04	.40	74LS298	1.50
7427	.25	7439	.65	74L10	.30	74LS367	1.95
7430	.20	7440	.75	74L20	.45	74LS368	1.25
7432	.30	7441	.85	74L30	.55	74LS373	2.50
7437	.20	7442	.75	74L47	1.95	74S00	.45
7438	.30	7443	1.10	74L51	.65	74S02	.45
7440	.20	7444	1.75	74L55	.85	74S03	.35
7441	1.15	7445	.90	74L72	.65	74S04	.35
7442	.55	7446	.95	74L73	.70	74S05	.45
7443	.45	7447	1.10	74L74	.75	74S08	.45
7444	.45	7448	.95	74L75	1.05	74S10	.45
7445	.75	7449	2.25	74L85	2.00	74S11	.45
7446	.70	7450	.75	74L93	.75	74S20	.35
7447	.70	7451	1.25	74L123	1.95	74S22	.55
7448	.50	7452	1.25	74LS00	.40	74S40	.30
7450	.25	7453	.75	74LS01	.40	74S50	.30
7451	.25	7454	.85	74LS02	.45	74S51	.35
7453	.20	7455	.95	74LS03	.45	74S64	.15
7454	.25	7456	.95	74LS04	.45	74S74	.70
7460	.40	7457	.95	74LS05	.45	74S112	.60
7470	.45	7458	.95	74LS08	.45	74S114	.85
7472	.40	7459	1.45	74LS09	.45	74S133	.85
7473	.25	7460	1.50	74LS10	.45	74S140	.75
7474	.30	7461	1.50	74LS11	.45	74S151	.95
7475	.35	7462	1.35	74LS20	.45	74S153	.95
7476	.40	7463	.65	74LS21	.45	74S157	.98
7480	.75	7464	.65	74LS22	.45	74S158	.80
7481	.85	7465	.20	74LS32	.50	74S194	1.50
7482	.95	7466	.30	74LS37	.45	74S196	2.00
7483	.95	7467	.30	74LS38	.65	74S257 (8123)	2.50
7485	.75	7468	.25	74LS40	.70	8131	2.75
7486	.55	7469	.35	74LS42	.95		
7489	1.05	7470	.35	74LS51	.75		
7490	.55	7471	.25	74LS74	.95		
7491	.70	7472	.45	74LS75	1.20		

### I<sup>2</sup>L, LINEARS, REGULATORS, ETC.

QTY.		QTY.		QTY.	
MCT2	.95	LM320K24	1.65	LM373	3.95
8038	3.95	LM320T5	1.65	LM377	3.95
LM201	.75	LM320T12	1.65	78L05	.75
LM301	.45	LM320T15	1.65	78L12	.75
LM308	.65	LM323K	5.95	78L15	.75
LM309H	.85	LM324	1.25	78M05	.75
LM309 (340K-5)	1.50	LM339	.75	LM380 (8-14 Pin)	1.19
LM310	.85	7805 (340T5)	1.15	LM709 (8-14 Pin)	.45
LM311 (8-14 Pin)	.75	LM340T12	.95	LM711	.45
LM318	1.50	LM340T15	.95	LM723	.40
LM320H6	.79	LM340T18	.95	LM725	2.50
LM320H15	.79	LM340T24	.95	LM739	1.50
LM320H24	.79	LM340K12	1.25	LM741 (8-14)	.45
7905 (LM320K5)	1.65	LM340K15	1.25	LM747	1.10
LM320K12	1.65	LM340K18	1.25	LM1307	1.75
LM320K15	1.65	LM340K24	1.25	LM1458	.65

LM3900	.95
LM75451	.65
NE555	.45
NE556	.85
NE565	1.15
NE566	1.25
NE567	.95
TA7205	6.95
76477	2.95
95H90	9.95

### SPECIAL DISCOUNTS

Total Order	Deduct
\$35-\$99	10%
\$100-\$300	15%
\$301-\$1000	20%

# OHIO SCIENTIFIC

Microcomputers from the world's largest  
full-line manufacturer



## The C2-4P Mini Floppy

20K RAM  
Basic + Assembler  
Personal, Games, Small  
Business & Educational Disks  
90K Mini Floppy Storage  
Printer Interface  
OS 65D V-30 Operating System  
Only £1595.00 Complete + VAT.

Economic expandable  
systems with good disk  
based software, available  
now.

See your nearest  
dealer for full price  
list and catalogue.

Other systems available include the C3 OEM with 32K RAM, 512K of disk storage and BASIC as standard, £2950.00 + VAT. (FORTRAN and COBOL available as extras.) All dealer enquiries direct to Abacus Computers Limited.

**Mutek**  
Quarry Hill, Box Corsham  
Wiltshire SN14 9HT  
Tel: 0225-743289

**Thames Personal  
Computers**  
13 Wilmot Way Camberley  
Surrey Tel: 0276-27860  
**Linn Products**  
235 Drakemire Drive  
Castlemilk Glasgow

G45 95Z Scotland  
Tel: 041-634 3860  
**U Microcomputers**  
PO Box 24 Northwich  
Cheshire CW8 1RS  
Tel: 0606-75627



# Appledem

G.F. Filbey, Department of Physics, Polytechnic of the South Bank, London

continued from June 79 PCW

1000-	20 00 0C	JSR	\$0C00	10A2-	AA	TAX		11A2-	85 6B	STA	\$6B
1003-	20 46 10	JSR	\$1046	10A3-	DE 00 0B	DEC	\$0B00,X	11A4-	A9 FF	LDA	##FF
1006-	A9 FF	LDA	##FF	10A6-	D0 E0	BNE	\$1088	11A5-	E0 BB 11	JSR	\$11BB
1008-	8D 2C 03	STA	\$032C	10A8-	E8	INX		11A9-	38	SEC	
100B-	EA	NOP		10A9-	DE 00 0B	DEC	\$0B00,X	11AA-	A5 6B	LDA	\$6B
100C-	A9 00	LDA	##00	10AC-	BD 00 0B	LDA	\$0B00,X	11AC-	E9 40	SBC	##40
100E-	A8	TRV		10AF-	85 6B	STA	\$6B	11AE-	85 6B	STA	\$6B
100F-	85 50	STA	\$50	10B1-	F0 0C	BEQ	\$10BF	11B0-	A9 00	LDA	##00
1011-	85 51	STA	\$51	10B3-	EA	NOP		11B2-	20 BB 11	JSR	\$11BB
1013-	85 69	STA	\$69	10B4-	EA	NOP		11B5-	4C C8 11	JMP	\$11C8
1015-	EA	NOP		10B5-	EA	NOP		11B8-	60	RTS	
1016-	8D 12 03	STA	\$0312	10B6-	EA	NOP		11B9-	00	BRK	
1019-	20 ED 11	JSR	\$11ED	10B7-	A9 FF	LDA	##FF	11BA-	00	BRK	
101C-	C9 25	CMP	##25	10B9-	20 BB 11	JSR	\$11BB	11BB-	8D 2C 03	STA	\$032C
101E-	D0 03	BNE	\$1023	10BC-	4C 88 10	JMP	\$1088	11BE-	A6 69	LDX	\$69
1020-	20 DB 10	JSR	\$10DB	10BF-	60	RTS		11C0-	A4 6A	LDY	\$6A
1023-	18	CLC		10B8-	18	CLC		11C2-	A5 6B	LDA	\$6B
1024-	A9 01	LDA	##01	10C0-	A9 09	LDA	##09	11C4-	20 7C 0C	JSR	\$0C7C
1026-	65 51	ADC	\$51	10E0-	65 69	ADC	\$69	11C7-	60	RTS	
1028-	85 51	STA	\$51	10E0-	85 69	STA	\$69	11C8-	C6 81	DEX	##81
102A-	A9 00	LDA	##00	10E2-	60	RTS		11CA-	D0 C0	BNE	\$11C0
102C-	65 50	ADC	\$50	10E3-	00	BRK		11CC-	C6 82	DEC	\$82
102E-	85 50	STA	\$50	112B-	20 00 0C	JSR	\$0C00	11CE-	EA	NOP	
1030-	C9 03	CMP	##03	112E-	A9 00	LDA	##00	11CF-	EA	NOP	
1032-	D0 E5	BNE	\$1019	1130-	85 69	STA	\$69	11D0-	D0 BA	BNE	\$118C
1034-	A6 69	LDX	\$69	1132-	25 6A	STA	\$6A	11D2-	EA	NOP	
1036-	EA	NOP		1134-	A9 9E	LDA	##9E	11D3-	EA	NOP	
1037-	DE 00 0B	DEC	\$0B00,X	1136-	85 6B	STA	\$6B	11D4-	EA	NOP	
103A-	BD 00 0B	LDA	\$0B00,X	1138-	A9 FF	LDA	##FF	11D5-	EA	NOP	
103D-	AC 12 03	LDY	\$0312	113A-	20 BB 11	JSR	\$11BB	11D6-	38	SEC	
1040-	20 7C 0C	JSR	\$0C7C	113D-	C6 6B	DEC	\$6B	11D7-	A5 84	LDA	\$84
1043-	4C 51 10	JMP	\$1051	113F-	C6 6B	DEC	\$6B	11D9-	E9 2A	SBC	##2A
1046-	A9 C0	LDA	##C0	1141-	A5 6B	LDA	\$6B	11DB-	85 82	STA	\$82
1048-	A2 00	LDX	##00	1143-	C9 8E	CMP	##8E	11DD-	85 84	STA	\$84
104A-	9D 00 0B	STA	\$0B00,X	1145-	D0 F1	BNE	\$1138	11DF-	A5 50	LDA	\$50
104D-	E8	INX		1147-	E6 69	INC	\$69	11E1-	38	SEC	
104E-	D0 FA	BNE	\$104A	1149-	E6 69	INC	\$69	11E2-	E9 7E	SBC	##7E
1050-	60	RTS		114B-	D0 E7	BNE	\$1134	11E4-	85 50	STA	\$50
1051-	A6 69	LDX	\$69	114D-	20 ED 11	JSR	\$11ED	11E6-	C6 83	DEC	\$83
1053-	BD 00 0B	LDA	\$0B00,X	1150-	29 FE	AND	##FE	11E8-	D0 A2	BNE	\$118C
1056-	D0 B4	BNE	\$100C	1152-	85 69	STA	\$69	11EA-	4C B8 11	JMP	\$11BB
1058-	60	RTS		1154-	20 ED 11	JSR	\$11ED	11ED-	A9 00	LDA	##00
1059-	0A	BRK		1157-	30 1B	BMI	\$1174	11EF-	85 08	STA	\$08
105H-	20 00 0C	JSR	\$0C00	1159-	29 0E	AND	##0E	11F1-	85 09	STA	\$09
105D-	20 46 10	JSR	\$1046	115B-	18	CLC		11F3-	A2 07	LDX	##07
1060-	A9 FF	LDA	##FF	115C-	69 90	ADC	##90	11F5-	18	CLC	
1062-	8D 2C 03	STA	\$032C	115E-	85 6D	STA	\$6B	11F6-	B5 00	LDA	\$00,X
1065-	20 ED 11	JSR	\$11ED	1160-	A9 00	LDA	##00	11F8-	65 08	ADC	\$08
1068-	EA	NOP		1162-	20 BB 11	JSR	\$11BB	11FA-	85 08	STA	\$08
1069-	EA	NOP		1165-	38	SEC		11FC-	A9 00	LDA	##00
106A-	85 69	STA	\$69	1166-	A5 6B	LDA	\$6B	11FE-	65 09	ADC	\$09
106C-	A6 69	LDX	\$69	1168-	E9 40	SBC	##40	1200-	85 09	STA	\$09
106E-	DE C0 0B	DEC	\$0B00,X	116A-	85 6B	STA	\$6B	1202-	CA	DEX	
1071-	EA	NOP		116C-	A9 FF	LDA	##FF	1203-	D0 F0	BNE	\$11F5
1072-	BD 00 0B	LDA	\$0B00,X	116E-	20 BB 11	JSR	\$11BB	1205-	18	CLC	
1075-	A0 00	LDY	##00	1171-	4C 8C 11	JMP	\$118C	1206-	A5 09	LDA	\$09
1077-	20 7C 0C	JSR	\$0C7C	1174-	29 0E	AND	##0E	1208-	F0 08	BEQ	\$1212
107A-	A6 69	LDX	\$69	1176-	18	CLC		120A-	65 08	ADC	\$08
107C-	BD 00 0B	LDA	\$0B00,X	1177-	69 90	ADC	##90	120C-	85 08	STA	\$08
107F-	D0 DF	BNE	\$1060	1179-	85 6B	STA	\$6B	120E-	90 02	BCC	\$1212
1081-	60	RTS		117B-	A9 FF	LDA	##FF	1210-	E6 08	INC	\$08
1082-	20 00 0C	JSR	\$0C00	117D-	20 B5 11	JSR	\$11BB	1212-	A5 08	LDA	\$08
1085-	20 46 10	JSR	\$1046	1180-	38	SEC		1214-	C9 FF	CMP	##FF
1088-	A9 FF	LDA	##FF	1181-	A5 6B	LDA	\$6B	1216-	D0 02	BNE	\$121A
108A-	EA	NOP		1183-	F9 40	SBC	##40	1218-	E6 08	INC	\$08
108B-	EA	NOP		1185-	85 0B	STA	\$6B	121A-	E8	INX	
108C-	85 80	STA	\$80	1187-	A9 00	LDA	##00	121B-	B5 01	LDA	\$01,X
108E-	20 ED 11	JSR	\$11ED	1189-	20 B8 11	JSR	\$11BB	121D-	CA	DEX	
1091-	E6 08	INC	\$08	118C-	20 ED 11	JSR	\$11ED	121E-	95 01	STA	\$01,X
1093-	A5 67	LDA	\$67	118F-	C5 50	CMP	\$50	1220-	E8	INX	
1095-	29 03	AND	##03	1191-	B0 BA	BCS	\$114D	1221-	E0 08	CPX	##08
1097-	EA	NOP		1193-	20 ED 11	JSR	\$11ED	1223-	D0 F5	BNE	\$121A
1098-	EA	NOP		1196-	29 FE	AND	##FE	1225-	A5 07	LDA	\$07
1099-	D0 F3	BNE	\$108E	1198-	85 69	STA	\$69	1227-	85 67	STA	\$67
109B-	A5 80	LDA	\$80	119A-	20 ED 11	JSR	\$11ED	1229-	60	RTS	
109D-	0A	ASL		119D-	29 0E	AND	##0E				
109E-	0A	ASL		119F-	18	CLC					
109F-	0A	ASL		11A0-	69 90	ADC	##90				
10A0-	85 69	STA	\$69								

concluded

# EQUINOX 300

A powerful multi-user  
multi-tasking  
multi-language

16-bit microcomputer time-sharing system

- supporting
- \* BASIC
- \* LISP
- \* PASCAL
- \* Floppy discs
- \* Hard discs

including a powerful Text Formatter,  
Assembly Language Development System  
and disc-based Sort utilities.

Priced from **under £5,000**

Write or phone for further information

**EQUINOX COMPUTER SYSTEMS LTD**  
**16 Anning Street,**  
**New Inn Yard**  
**London E.C.2.**  
**(Tel: 01-739 2387/8/9)**

## ENTERPRISES

### RECENT ADDITIONS TO OUR RANGE OF BOOKS

- RA6800HL** — An M6800 Relocatable Macro Assembler by J.E. Hemenway **£15.95**
- LINK 68** — An M6800 Linking Loader by Grappel and Hemenway **£ 5.50**
- Calculating with BASIC** by R. Guido **£ 4.95**
- Users Guide to North Star BASIC** by R.R. Rogers **£10.00**
- Programming the 6502** by R. Zaks **£ 7.95**
- SCELBAL High Level Language** plus supplements by Arnold & Wadsworth **£20.00**
- PIMMS** — A Database Management System **£ 5.95**
- Program Design** ed. by Liffick **£ 4.25**
- 6800 Tracer** — an aid to 6800 Program debugging **£ 3.95**
- MONDEB** — An advanced M6800 Monitor Debugger by D Peters **£ 3.50**
- SUPER-WUMPUS** — a game in 6800 Assembler code and BASIC, by J. Emmericks **£ 4.25**

#### HOW TO ORDER

Send cash with order to L.P. Enterprises,  
Room NB/PW, 313 Kingston Road,  
Ilford, Essex IG1 1PJ. Credit card orders  
(not Diners Card) accepted by telephone.  
Tel No.: 01-553 1001.  
Payments must be in sterling and  
drawn against a British Bank.

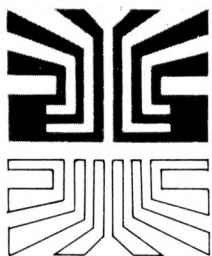

## Small Systems Engineering Limited

62 CAVENDISH STREET, LONDON W1M 7LD  
TELEPHONE: 01-637 0777. Telex: 8813085 ABACUS

SUPPLIERS OF PET MEMORY BOARDS AND INTERFACES THROUGHOUT EUROPE

#### PET MEMORY BOARDS

Sole official U.K. Agent for PME memory boards. We provide approved technical back-up, up-grade and service facilities for these boards in the U.K. internally mounting memory boards available in 2 configurations; — 24K — **£328** — 32K — **£432**.

#### IEEE-488/RS232C SERIAL INTERFACE

- Full IEEE address decoding, R232C or 20MA Loop output,
- Switch selectable Baud Rate, Crystal controlled Baud Rate timing, Lower case Printing
- Boxed units complete with connectors, full operating instructions and sample programs supplied,
- Serial Interface B, input & output **£186**.
- Serial Interface A, output only, **£106**.

#### CUSTOM INTERFACE DESIGN

Interfaces designed for special applications. Interfaces supplied so far include Analog Input/Output, XY plotter, stepper motor control.

#### PET INTELLIGENT TERMINAL SOFTWARE PACKAGE

A software package which, in conjunction with an Interface B enables the PET to operate as an intelligent terminal. The software implements full IBM or DEC protocols **£100**.

#### TV/VIDEO MONITOR INTERFACE

- Video and UHF output (plugs into TV aerial socket) **£35**

#### IEEE-488/CENTRONICS TYPE PARALLEL INTERFACE

- Low cost unit without IEEE address decoding
- Also suitable for Anadex DP-800 Printer **£45**.

#### P & T-488 S-100 IEEE-488 INTERFACE

- Interfaces S-100 computers to the IEEE-488 instrumentation bus.
- Functions as a 488 controller, talker or listener.
- Three software packages available:
  - North Star DOS/BASIC Interface
  - CP/M Interface
  - Custom systems interface package **£325.00**

#### Available now:

#### COMPUCOLOUR II MODEL 3

- 13" 8-Colour CRT, 8080 Microprocessor
- 16K extended disk BASIC in ROM
- 71-key detached keyboard
- 8K RAM memory for user programs
- 64 characters per line by 32 lines per page
- Special graphics package with 128 x 128 point plotting
- Built-in mini-floppy disk drive
- 50 pin bus
- RS-232 I/O port for serial printers, etc. **£1,390.00**

**TERMS:** All prices Ex. VAT. All order C.W.O. Cheques should be made payable to:

#### SMALL SYSTEMS ENGINEERING LTD.

Orders should include £2.50 p&p per unit. All goods supplied under 90 days warranty.

**EXIDY SORCERER**

A COMPLETE BUSINESS SYSTEM UNDER £3000 + VAT 32K Machine with Z80 processor and 8K PROM BASIC. 128 character ASCII keyboard and superb graphics. DOUBLE DRIVE configured MICROPOLIS DISK SYSTEM with MDOS or CP/M 630Kb Professional quality monitor, various sizes up to 16". Printer — optional 80 or 132 column printer. Software packages are available or can be written to your own specification. The system can be expanded to suit your own applications. **UNDER £1000** — BASIC SYSTEM 32K Machine, 10" professional monitor (not a converted TV), quality cassette recorder, necessary cables, manuals etc. Price **£999** + VAT. Sorcerer Prices from **£650** (8K)

**CROMEMCO, NORTH STAR HORIZON AND SOL****77/68 BEARBAGS**

The well supported 6800 based kit from Newbear. Active user group.

**PRINTERS**

NEW DOLPHIN BD 80 PRINTER. Low cost 80 column printer combining simple mechanical design with sophisticated micro processor control, upper and lower case, 112 CPM, many features. Stand, cables, memory buffers available. Ex. stock prices from **£595.00**. Dealer enquiries invited.

CENTRONICS AND OKII.

**MONITORS**

Professional quality 9", 10", 12", 16" (ideal for teaching)

**TAPE RECORDERS**

SONY CASSETTE RECORDER **£34.95**

**C12 COMPUTER CASSETTES**

45p each or 10 for **£4.00**

**COMPUTER BOOKS**

Catalogues available. SPECIAL OFFER FOR AUGUST ONLY HOLIDAY READING. Intro to Personal and Business Computing **£4.80**. The Mind Appliance — Home Computer Applications **£4.00**. Micros from Chips to Systems **£6.80**. 110 Cosmos Digital IC Projects for the Home Constructor **£2.65**. Illustrating Basic **£2.10**. Programming the 6502 **£7.25**. The Micro Processor and Its Application **£12.25**. 8080 Galaxy Game **£5.50**. How to Build a Computer Controlled Robot **£4.75**.

**THE COMPLETE SERVICE**

**Feasibility studies** — undertaken by our senior analysts with long experience of commercial data processing. **Software** packages available and/or specially designed and written for your own applications.

We can supply **work stations** for your computer hardware, standard configurations or made to measure. Insurance, maintenance, HP facilities. **BARCLAYCARD, TRUSTCARD, ACCESS.**

Universities, Colleges and Schools — official orders welcome.

**OFFICES & SHOWROOM** — Open Monday — Saturday 10.00 a.m. to 6.00 p.m. Personal callers welcome (Please Phone first)

34B LONDON ROAD, BLACKWATER, CAMBERLEY, SURREY.

Telephone: (0276) 34044 Telex: 858893

# Error Messages

With reference to my renumbering routine for TRS-80 published in the MAY 1979 issue, an error crept into the listing and line 224 should be ADD HL, DE not BC.

I have made several improvements since writing the article last year, which although not necessary to its functioning, I would recommend adding to tidy things up.

1. Delete lines 210 to 212 inclusive and replace them by

```
LDIR
LD A, STAR           ; check if any trailing
EX DE, HL           ; stars left
CHKSTR CP (HL)
JR NZ, ERRRET-$
LD (HL), SPACE      ; clear them out
INC HL
JR CHKSTR-$
ERRRET POP IX
```

2. Delete lines 230 to 247 inclusive and replace them by

```
LD HL, ERRMES
CALL OUTSTR         ; output 'omitted'
POP HL
CALL OUTSTR         ; output number
                    ; omitted
LD HL, (CURSOR)
LD A, L
OR OFH              ; tab across screen
LD L, A
INC HL
LD A, H
LD (CURSOR), HL
CP 40H              ; end of screen?
JR NZ, ERRRET-$
CALL KBD            ; wait for key
CALL CLS
```

3. Also declare OUTSTR EQU 28A7H; this prints a string pointed to by HL and terminated by O.

To provide the zero for the above a DEFB O must be put after the DEFM 'OMITTED:' and also after the TEMP DEFS 5.

This increases the size of the program so the ORG must be changed to 4E3DH for a 4k and 7E3DH for a 16k machine and the entry points will now be 20029 for 4k and 32317 for 16k machines. MEMORY SIZE must be adjusted similarly to one less.

The entry points for the published version should of course be 20040 and 32328.

**I. Addinsell**

**Author's address:** Top of the Hill, Windmill Lane, Preston on the Hill, Nr. Warrington, Cheshire.

In Clifford Clark's 'Diagnostic Program', (PCW, May) p23, col 2, para 1, lines 14 & 15 should read: "These locations are in the 'Display Memory Section' as illustrated in the March 79 Issue, p25, fig. 1."

## OPERATE YOUR Z80 AS A 40-BIT FLOATING POINT ARITHMETIC PROCESSOR WITH DECIMAL INPUT/OUTPUT

**MAPPI-3Z**, entered by a Z80 call instruction, changes Z80 operation to two 40-bit floating point registers and a 16 bit symbol register — programmed by 39 instruction codes including: ASCII decimal string interpret/input, ASCII decimal output, load, read and write binary, push, pop and exchange registers, cond. and uncond. rel. jumps, load, read and write symbol, add, subtr., mult., div., square, recip., sq.rt., abs., neg., cosine, sine, ln, log, exit with error indicator to software interface, return to Z80 code.

Use Z80 and MAPP object codes in the same programme! **RELOCATABLE SOFTWARE IN 3K MEMORY**, suitable for Z80 systems with an additional 1K RAM (including stack) and operating in machine code.

**MANUAL AND DESCRIPTIVE LISTING** with either

- (i) Nascom tape **£12.90**
- or (ii) Research Machines tape **£12.90**
- or (iii) Three 2708 EPROM **£45.00**

Inclusive prices. Please specify tape or eprom as required and send cheque or P.O. to

**ENERTECH LTD.,**  
32 Gildredge Road, Eastbourne, East Sussex, BN21 4SH.  
Trade enquiries welcome.

# THE AMAZING COMPUCOLOR II

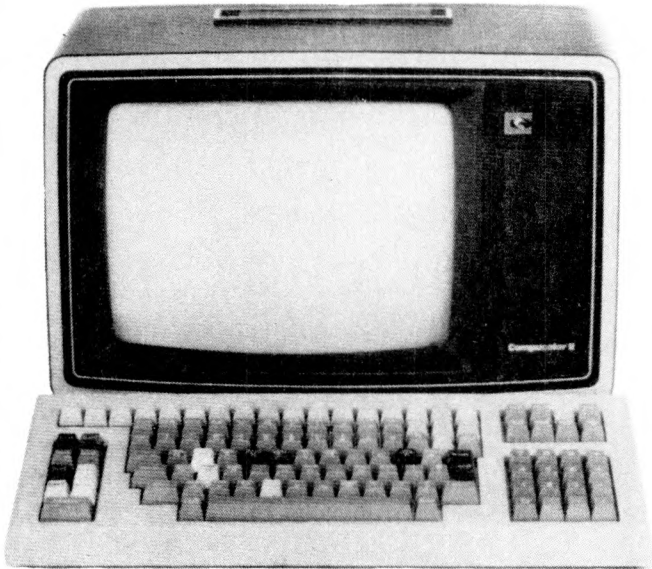

WITH

8-Colour Graphics  
Integral Mini-Disk  
Up to 32K RAM

*You've heard all about it —*

## Now come and see it!

on the Abacus stand at the 1979 Microcomputer Show,  
Bloomsbury Centre Hotel, 5th-7th July.

**Delivery four weeks or better, with full technical support  
from European distributors**

DEALER ENQUIRIES INVITED

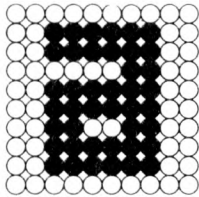

Abacus  
Computers  
Limited



Small Systems  
Engineering Limited

62 New Cavendish Street, London W1M 7LD. Tel: 01-580 8841/2. Telex: ABACUS G 8813085

# SIRTON PRODUCTS

13 WARWICK ROAD, COULSDON, SURREY CR3 2EF Tel: 01-660 5617



**DON'T BORE YOUR COMPUTER WITH DATA PREPARATION!**

Let it run programmes that work for you while the TEXTOR is used to edit programmes and data off line.

TEXTOR has 2K of user memory, text editing facilities, and transmits and receives via serial link to your Computer

## TEXTOR

## MIDAS

### MIDAS S.100 SYSTEMS

Substantial Mainframe to house your S100 system, with optional 5" or 8" disc drives. Special systems built to your requirements from Z80 CPU and other S100 boards held in stock

Mainframes from £228

MIDAS 1 : Z80 System from £625 (built)

MIDAS 2 : Z80 Disc System from £1100 (built)

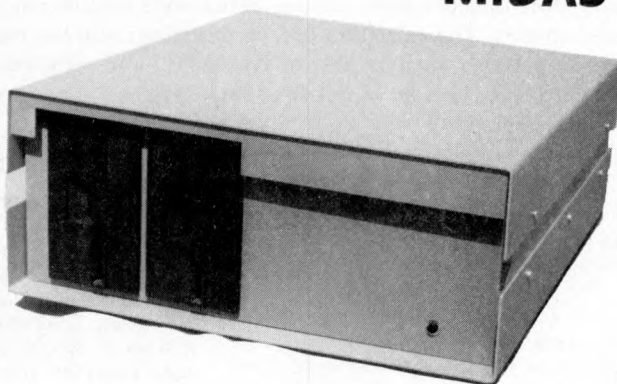

# The ITHACA DPS-1

Professional versatile computer system with comprehensive front panel facilities and 20-slot motherboard. Units have substantial power supply etc. and come with 2 or 4 MHz Z80 CPU. BUS conforms to the IEEE S100 standard.

DPS.1 from £695

### STOP PRESS!

Siemens 8" Drives @ £325

EPROM Erasers (240V) @ £38.00

#### Suppliers for:

JADE INC.  
CROMEMCO  
S D SYSTEMS  
ITHACA AUDIO  
ETC & SSM  
GODBOUT  
& others

#### Comprehensive Range of S100 Boards Stocked

Bare Boards — Kits — Built & Tested

VIDEO RAM  
ROM  
DISCS CPU  
PARALLEL/SERIAL I/O

WRITE OR PHONE FOR CATALOGUE

#### SOFTWARE

BASIC  
CP/M DOS  
Z80 ASSEMBLER  
MONITOR  
BIOS

# The Programmed Punter

PERMS

A BASIC COMPUTER PROGRAM FOR THE BETTING MAN

Dr. M.R.J. Morgan

Department of Biological Sciences, University of Lancaster



Many of us enjoy the occasional flutter at the races, and filling in the weekly football pools coupon is something of a national pastime. Napoleon Bonaparte saw us as a "nation of shopkeepers" and the betting shop has become a familiar feature of every High Street, a symptom of recent explosive growth in the gambling industry. The professional gambler studies the odds as a way of life because for him betting is a serious business. We amateurs can increase the fun of betting if we make the effort to understand something of the mathematical basis of gambling and a good place to start is with permutations. This BASIC program offers the punter the means of determining the number of possible permutations over a wide enough range to cover all likely requirements. The calculation of permutations also has more "serious" applications, notably in the fields of probability and statistics. Closer familiarity with such concepts and a better appreciation of the odds may give the punter food for thought.

## Background

The number of possible permutations of N from M is given by:

$$\frac{M!}{N! (M-N)!}$$

where the shriek notation! denotes the factorial of the adjacent number, e.g. the factorial of 5 is 5! or  $5 \times 4 \times 3 \times 2 \times 1 = 120$ . Suppose we want to determine the number of possible treble bets for 8 horses (in different races), then the calculation uses  $N = 3$ ,  $M = 8$  and  $(M-N) = 5$  so that the expression becomes:

$$\frac{8!}{3! \times 5!} = \frac{8 \times 7 \times 6 \times 5 \times 4 \times 3 \times 2 \times 1}{(3 \times 2 \times 1) \times (5 \times 4 \times 3 \times 2 \times 1)} = \frac{40320}{6 \times 120} = 56$$

If funds are short we might decide to eliminate one or two of our selections to reduce the number of treble bets to 35 for 7 horses, or 20 for 6 horses. Alternatively we might prefer to retain the original 8 selections but to bet all possible doubles instead, giving 28 bets. Similarly, when filling in our football pools coupon, we can calculate that for a full perm of any 8 from 10 we will need to subscribe to 45 lines. Increasing the number of selections to 11 or 12 increases the number of lines required to 165 or 495 respectively, so we may well want to reduce our stake per line.

For fairly small numbers these calculations are not terribly difficult but they tend to become tedious if more than one or two have to be executed. With larger numbers the calculations can become quite time-consuming and are very prone to error. Why not let the personal computer do the donkey work? (PCW Here we have the not implausible implication that only donkeys bet on horses PCW)

## Running the Program

The program makes full use of the conversational facilities of BASIC and is largely self-explanatory. Two modes of operation are offered. Mode 1 provides a complete tabulation of permutations of N from M for all values of N and M between 1 and 20. The table is best suited to hard-copy output and is printed in four sections so as to fit into standard teletype format; the complete table is then obtained by cutting the teletype paper and pinning up the four sections in horizontal alignment. The complete table is suitable for display on the wall of your local betting shop, at the club, for your pools syndicate, or your den at home. A permanent copy of the table will meet many regular needs and stand you in good stead with the lads of the betting fraternity. It will come in handy for settling arguments, or even bets!

The second, alternative, mode of the program permits the calculation of particular permutations, one at a time, over a much wider range of values of N and M. This mode of operation is suitable for any output device, including VDUs; the program accepts your chosen values of N, M and recycles indefinitely to assist your studies of probability theory. When you have finally perfected your understanding and conjured up the ideal full perm or master bet, your exit from the program is accompanied by some sound advice from the computer.

## How the Program Works

For the calculation of individual permutations the necessary factorials M!, N! and (M-N)! are evaluated in turn in a simple subroutine and then the ratio M!/N! x (M-N)! is determined. When using larger numbers for N or M the factorial calcu-

lation involves many terms and it is easy to cause an overflow at statement 2040 unless steps are taken to avoid doing so. For the BASIC system under which the program was written the upper limit of the numerical range is approximately  $10^{76}$  which means that the largest factorial that can be calculated is  $57! = 4.05 \times 10^{76}$ .

Statements 1200 - 1260 check that N and M are within the range 1 to 57 and that M is greater than N. It is essential that N, M and (M-N) should not assume the value 0 or become negative. By definition, the factorial of zero is unity,  $0! = 1$ , but this special case would not be correctly handled by the factorial subroutine as it stands. Although it would be quite easy to incorporate a special treatment for 0! in the subroutine, it is not worth doing so in this application because zero values cannot arise in real-life input. Similarly, it is not possible to calculate factorials for negative values, so the program checks that these have not been inadvertently introduced. There is one real condition not catered for by the program, namely where  $N = M$  so that  $(M-N) = 0$ , but this is trivial because it should be fairly obvious that there is only 1 possible permutation of, say, 37 from 37 (or 22 from 22, etc.). Clearly, it is only possible to calculate factorials for integral values, so as a final safeguard, if any non-integral values are input inadvertently for N or M, the program takes the corresponding integer numbers.

In the alternative mode of operation leading to the output of a table of permutations, the program builds up the numbers required for the table in a matrix. The value taken by the numbers occupying the cells of the matrix is derived from adjacent elements of the array, without employing the factorial subroutine.

	x	y	
		z	

This is possible because the number in each cell is equal to the sum of the number in the cell immediately above it in the same column plus the number in the cell one column to the left and one row above,  $z = x + y$ .

## Technical Points

### Strings

In the teletype listing of the program, the

dollar sign \$ is represented as a back-slash \; thus A\ should be read as A\$.

For the ICL BASIC Interpreter X98B under which the program was written there is a standard string length of 15 characters. For other BASIC Interpreters or Compilers it may be essential or desirable to dimension all strings. The program only uses a single string and this could be catered for by inserting the statement:

```
1075 DIM A$(3)
```

Matrix Statements

For versions of BASIC without matrix-

handling facilities, the statement: 1680 MAT PRINT Q

can be replaced by FOR loops enclosing a PRINT statement referring to the required element of array Q.

FOR Loops

The statement:

```
2030 FOR J = 2 TO X
```

will only rarely give rise to problems but, if your version of BASIC will only step from 1, replacing this statement with:

```
2030 FOR J = 1 TO X
```

will not affect the calculations.

Numerical Range

The ICL BASIC Interpreter can handle numbers up to approximately 10^76. If your version of BASIC has a lower limit you should decrease the value of 57 appropriately at statements 1240 and 1250 to avoid overflow problems at statement 2040. Conversely, if your BASIC can cope with numbers up to, say 10^99 you will be able to calculate factorials up to 69! and can modify statements 1240 and 1250 accordingly.

```
1000 PRINT
1010 PRINT
1020 PRINT
1030 PRINT "PROGRAM FOR THE DETERMINATION OF PERMUTATIONS"
1040 PRINT "*****"
1050 PRINT
1060 PRINT
1070 PRINT
1080 PRINT "DO YOU WANT A FULL TABLE OF PERMUTATIONS OF N FROM M"
1090 PRINT "FOR ALL VALUES OF N AND M BETWEEN 1 AND 20?"
1100 PRINT "PLEASE ANSWER YES OR NO":
1110 INPUT A\
1120 IF A\ = "YES" THEN 1500
1130 IF A\ = "NO" THEN 1170
1140 GOTO 1100
1150 PRINT "SORRY, N AND M MUST BOTH BE IN THE RANGE 1 TO 57"
1160 PRINT "AND, OF COURSE, M MUST BE GREATER THAN N"
1170 PRINT "INPUT YOUR CHOSEN VALUES OF N,M AND I WILL TELL YOU"
1180 PRINT "THE NUMBER OF POSSIBLE PERMUTATIONS OF N FROM M":
1190 INPUT N,M
1200 LET N = INT(N)
1210 LET M = INT(M)
1220 IF N < 1 THEN 1150
1230 IF M < 1 THEN 1150
1240 IF N > 57 THEN 1150
1250 IF M > 57 THEN 1150
1260 IF M <= N THEN 1150
1270 LET X = M
1280 GOSUB 2020
1290 LET M1 = F
1300 LET X = M
1310 GOSUB 2020
1320 LET N1 = F
1330 LET X = M-N
1340 GOSUB 2020
1350 LET D1 = F
1360 PRINT
1370 PRINT
1380 PRINT
1390 PRINT "THERE ARE";M1/(N1*D1);"POSSIBLE PERMUTATIONS OF";N;"FROM";M
1400 PRINT
1410 PRINT
1420 PRINT
1430 PRINT "DO YOU WANT TO CALCULATE ANOTHER PERMUTATION?"
1440 PRINT "PLEASE ANSWER YES OR NO":
1450 INPUT A\
1460 IF A\ = "YES" THEN 1170
1470 IF A\ = "NO" THEN 2070
1480 GOTO 1440
1490 REM PERM ANY N FROM M
1500 DIM P(20,20), Q(20,5)
1510 FOR N = 1 TO 20
1520 FOR M = 1 TO 20
1530 LET L = 1
1540 FOR J = 1 TO N
1550 LET K = M+1-J
1560 LET L = L*K/J
1570 NEXT J
1580 LET P(M,N) = L
1590 NEXT M
1600 NEXT N
1610 FOR J = 0 TO 3
1620 FOR N = 1 TO 5
1630 FOR M = 1 TO 20
1640 LET Q(M,N) = P(M,N+J*5)
1650 NEXT M
1660 NEXT N
1670 GOSUB 1770
1680 MAT PRINT Q
1690 PRINT
1700 PRINT
1710 PRINT
1720 PRINT
1730 PRINT
1740 NEXT J
1750 GOTO 2070
1760 REM TABULATION SUBROUTINE
1770 PRINT
1780 PRINT
1790 PRINT
1800 PRINT TAB(20);
1810 PRINT "TABLE OF PERMUTATIONS"
1820 PRINT TAB(20);
1830 PRINT "*****"
1840 PRINT
1850 PRINT
1860 PRINT
1870 PRINT
1880 PRINT "ANY --->"
1890 FOR K = 1 TO 5
1900 PRINT TAB(15*(K-1));
1910 PRINT K+J*5;
1920 NEXT K
1930 PRINT
1940 PRINT
1950 PRINT
1960 IF J > 0 THEN 1990
1970 PRINT "FROM"
1980 GOTO 2000
1990 PRINT
2000 RETURN
2010 REM FACTORIAL SUBROUTINE
2020 LET F = 1
2030 FOR J = 2 TO X
2040 LET F = F*J
2050 NEXT J
2060 RETURN
2070 PRINT "OK BEST OF LUCK WITH YOUR PUNTING"
2080 PRINT "BUT REMEMBER THE ODDS YOU ARE UP AGAINST!"
2090 END
```

# a digitizer adds another dimension

The Bit Pad computer digitizer converts graphic information into digital form for direct entry into a computer. By touching a pen like stylus or a cursor, to any position on a drawing, diagram, photograph, or other graphic presentation, the position co-ordinates are converted to digital equivalents.

- Bit Pad interfaces with almost any micro computer.
- Bit Pad consists of a 15" sq. digitizer tablet (11" sq. active area), a stylus, and a controller cabinet.
- Bit Pad costs only £450 (excluding VAT). Fill in the coupon and we will send you full information and details.

Terminal Display Systems Ltd. Hillside, Whitebirk Industrial Estate Blackburn BBI 5SM Lancs. England

Send to: Department CPPW, Terminal Display Systems Ltd., Hillside, Whitebirk Industrial Estate, Blackburn BBI 5SM, Lancs. England

Name .....

Address .....



Microscopy, Network Architecture  
 Structural Geology, Mechanical Engineering  
 Computing, Exam marking  
 Teaching, Social research  
 Measuring Buildings, Management Military  
 Menus, Market research, Geographical  
 Cartographic, Archeological, Town Planning  
 Orthodontics, Design, Geology, Statistics, Traffic  
 Radiology, Microscopy, Artwork, Architecture  
 Structural, Civil, Mechanical, Electrical  
 Process Control, Graphics, Marketing  
 Teaching Games, Research, Arch  
 Measuring, Biological, Library  
 Menus, Market research, Social  
 Archeological, Accounting, Design  
 Design, Geology, ...

## DPS-1

Introducing the **DPS-1** the full IEEE S100 bus computer system from Ithaca Intersystems — the S100 experts.

**FOR EDUCATION, INDUSTRY, RESEARCH** and all professional uses, including hardware and software development, low cost OEM systems, teaching applications etc.

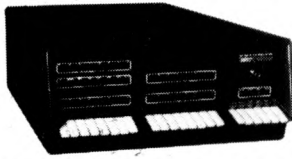

**A MINI COMPUTER** using MICRO technology at a ridiculous MICRO price!! The front panel with a backplane and power supply accepts S100 bus boards from many manufacturers.

### Just look at these professional features!

★ **FRONT PANEL** (we won't ask you to debug our hardware, but we will give you the tools to debug yours!). Includes breakpoints, write or jump to any location, single or slow step (0.1 to 1000 IPS), stop on any data byte or address, scope trigger on breakpoint, repeat instruction (e.g. NOP's) and many other hardware diagnostic facilities.

- ★ 25 Amp power supplies (all rails separately fused)
- ★ 20 slot IEEE S100 motherboard
- ★ Full 16 data bit, 24 bit address lines as per IEEE (1979) S100 specification
- ★ Will run 16 bit micro S100 boards when available (e.g. Z8000 and 8086)
- ★ Suitable for 6800, 6502, 8080, 8085, Z80, Z80A etc.

The **DPS-1** comes as a mainframe with front panel, motherboard and power supply. The system is truly modular allowing the user to build up the system he requires in his own time.

S100 boards from a number of manufacturers will plug into the DPS1 IEEE S100 bus.

Just add S100 Memory Boards — S100 cpu board — S100 disk controller boards — S100 I/O boards — S100 video and/or graphics boards — S100 EPROM boards — S100 disk boards etc.

All Ithaca Intersystems OEM products including K2 disk operating system and PASCAL/Z on 8" floppy drives will run in the DPS-1.

**DPS-1 with S100 Z80 cpu board £695**

**DPS-1 less S100 Z80 cpu board £645**

## OEM S100 boards from the experts!

	bare board	Assembled and tested
8K Static RAM board	£18.75	£123.75
Z80 cpu board (2MHZ)	£26.25	£131.25
Z80 cpu board (4MHZ)	£26.25	£153.75
2708/2716 EPROM board	£18.75	£63.75
Prototype board	£18.75	—
Video display board (64x16, 128U/L Ascii)	£18.75	£108.75

### New products from Ithaca audio!

High density graphics (1024 x 512 points)	T.B.A.	T.B.A.
Disk controller (up to 4 single or double sided drives)	£26.25	£131.25
I/O board (serial and parallel outputs)	T.B.A.	T.B.A.
S100 front panel (as used in DPS1)	—	£245.00

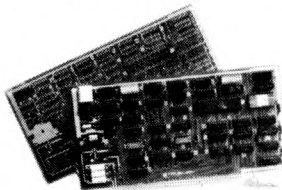

Over 15,000 boards delivered worldwide

# InterSystems

## Software for your S100 system

### K2 operating system

8" disk based operating system — distributed on Shugat compatible 8" floppy disk ★ TED—52 command text editor with Macros. ★ PIP—File and directory handler. ★ ASMBLE—full Z80 2 pass assembler. ★ HDT—Hex debug tool. ★ QCI—Utility overlay/command decoder. ★ SYSGEN—System builder. ★ COPY—disk to disk file copier. ★ DUP—disk duplicator. **£56.25**

### PASCAL/Z The new language for Micros £131.25

Runs under K2 operating system.

★ Compiler that produces direct assembler code — NO NEED for slow run time P-code interpreter. ★ Comes complete with Macro assembler. ★ Produces binary object modules — small and fast. ★ Modules are re-entrant and can be put into ROM. ★ IMBED, TRACE and ERROR debug facilities.

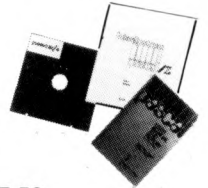

### ASMBLE/Z Z80 Macro assembler £37.50

★ Full 2 pass Macro Assembler. ★ IF and ELSE — 255 nesting levels. ★ Produces symbol table. ★ Relative jumps.

## UP-GRADE KITS

Trying to add computer memory is not much fun if you don't get everything you need.

with concise step by step directions and diagrams. And if a personality jumper is required, it's premade.



Receiving unprogrammed jumpers and having to program them yourself is not much better. Most important, that's the place where the problems are introduced. So Ithaca Audio's better idea is the Simple Up-Grade. Each Simple Up-Grade is specially designed to make adding memory foolproof. We include all the parts you'll need; 8 prime, tested 16K RAMs, along



The TRS-80\* memory expansion was our first Simple Up-Grade. Now there are two more — for owners of Apple II\*\* and Exidy Sorcerer\*\*\* computers. Each kit is 100% guaranteed — if a part ever fails, we replace it FREE. Your Ithaca Audio dealer has them in stock, only £99. Now you can afford to add high quality, high density memory to your system for remarkably little — far less than you would expect to pay from Radio Shack, Apple, or Exidy directly. These Simple Up-Grades are Ithaca Audio's first step in adding more capability and reliability to your computer at lower cost. Other Up-Grades are on the way to your dealer now. \*TRS-80 is a registered trademark of Tandy Corp. \*\*Apple II is a registered trademark of Apple Computer, Inc. \*\*\*Sorcerer is a registered trademark of Exidy, Inc.



### CONTACT THESE DEALERS

**NEWBEAR COMPUTING STORE** — Telephone: Newbury (0635) 30505 **AIRAMCO** — Telephone: 0294 57755 Telex: 779808  
**SIRTON PRODUCTS** — Telephone: 01-660 5617 **COMPSHOP LTD** — Telephone: 01-441 2922 Telex: 298755

**ITHACA Intersystems**

(formerly ITHACA AUDIO of New York)

**UK & EUROPEAN DEALER ENQUIRIES INVITED — CONTACT EUROPEAN SALES HEADQUARTERS**

58 Crouch Hall Road, London N8 8HG. UK. Telephone: 01-341 2447 Telex: 299568

All prices quoted are exclusive of VAT.



## NORTH STAR COMPATIBLE SOFTWARE

### ALLEN ASHLEY ENTERPRISES

PDS Program Development System for 8080 or Z80 computers .. £75.00

PDS is an exceptionally powerful assembly language development package. PDS includes a unified assembler/editor, a macro assembler with a relocating linking loader, a string-oriented text editor and trace debugger/disassembler. PDS supports full Z80 code favouring the Intel instruction mnemonics, treating the Z80 superset as a logical and syntactical extension.

The following is a list of source modules compatible with PDS:-

MODULE	FUNCTION	REQUIREMENTS	
ALPHSORT	High speed alphabetic sort	None	£10.00
NUMRSORT	High speed numeric sort	None	£10.00
FPPACK	BCD floating point arithmetic	None	£10.00
FOURIER	Fast Fourier transform	FPPACK	£10.00
MINV	Matrix inversion	FPPACK	£ 7.50
MATPED	Matrix product	FPPACK	£ 7.50
RATPOL	Rational function and utilities	FPPACK	£ 5.00
SORT	Square root	FPPACK	£10.00
TRIGS	Sine, cosine, TAN, ATAN	FPPACK, RATPOL	£10.00
LOGEXP	Exponential, logarithm, $\gamma^x$	FPPACK, RATPOL	£10.00
FPIOP	Floating point I/O	None	£10.00
FORMAT	Formatted floating point output	None	£ 7.50
NFILES	North Star disk handler	None	£10.00
INOPS	Integer multiply/divide	None	£ 5.00
The complete set of modules (listed above) .....			£59.00

### BYTE SHOP OF WESTMINSTER

NORTHSHARE North Star BASIC time sharing package ..... £37.00

The NORTHSHARE system allows you to make much better use of your 8080 or Z80 CPU by allowing you to connect two to four terminals to your system and running North Star BASIC in a timesharing mode. Each terminal shares the same copy of BASIC simultaneously; but independent of the other user(s). All book-keeping is done by a separate task supervisor.

### DIGITAL RESEARCH

CP/M\* with Horizon customisation ..... £90.00

CP/M is a proprietary general-purpose operating system for Intel 8080 or Zilog Z-80 microcomputer systems. CP/M's basic facilities include dynamic file management, a fast assembler, a general purpose text editor and an advanced debugger.

MAC Macro Assembler, features include assembly-time expressions, conditional assembly, page formatting and a powerful macro assembler ..... £65.00

SID Symbolic Instruction Debugger ..... £60.00

TEX Text formatter ..... £60.00

DESPOOL permits simultaneous printing of data from disk while user executes another program from the console ..... £45.00

### NORTH STAR SOFTWARE EXCHANGE

NSSE1 Six games plus four utility programs ..... £ 6.00

Games: Chomp, Lunar, Slots, Match, Startrek and Wumpus.  
Utilities: Memory 16, Memory 24, Memory 32 and Defunct.

NSSE2 Assortment of utility programs ..... £ 6.00

Utilities: File, Heaps, TST16K Compact, Hexdec, Memset, Filedit, Memrymap, Sort and Alphsort.

NSSE3 This disk is entirely devoted to the Guess game ..... £ 6.00

NSSE4 Mathematical routines mostly for matrix manipulations ..... £ 6.00

Routines: Fast Fourier Transform, Gaussian Reduction, Matrix Multiplication, Matrix Inversion and Gaussian Elimination.

NSSE5 Complete assembler source code for the PILOT system .. £ 6.00

NSSE6 Assortment of applications programs ..... £ 6.00

Programs: Library, Mailer, Intrate, Biorhythm, Chekbook.

NSSE7 Games, mainly for use with SOL video board ..... £ 6.00

NSSE8 Games programs, mostly in the form of simulations .... £ 6.00

Games: Othello, Zoo, Hamurabi, Gunner, CIBM, Trek 16K.

The above programs have been certified by their contributors as being in the public domain. Neither North Star Computers Inc. or Interam Computer Systems Ltd. make any claim or offer any warranty that the programs are correct or suitable for any purpose. The set of eight diskettes containing software is priced at ..... £35.00

### NORTH STAR

PASCAL development system includes an editor, compiler, debugger and file handler ..... £37.00

PAS-AUX Auxillary package for above, includes an assembler and utilities ..... £27.00

The above software is supplied on 5.25" diskettes. Prices are exclusive of VAT @ 8% and postage & packing (add 75p). Please send large s.a.e. for full details.

Coming soon - Applications software, including General Ledger package for incomplete records and an Inventory package.

Software products are being continually added to our range, so please enquire about software products not listed above.

INTERAM Computer Systems Ltd.  
59 Moreton St. Victoria, London SW1

01-834 0261/2733

**INTERAM**

## NASCOM FLOATING POINT

**BASIC LEVEL C** Runs on an 8K system

Full floating point arithmetic

Software compatible with Levels A and B

Contains all features found on A and B plus more

Line editor, 52 variables

Commands include:- FOR; NEXT; READ; DATA;

PEEK; POKE; IN; OUT; USR; INKEY

**BASIC LEVEL A** Runs on the minimum Nascom

No extra memory needed

Fitted in 2 minutes in place of monitor

Integer arithmetic <, >, <>, <=, >=, =

Fast execution time

Keyboard pause and interrupt

Abbreviated commands allow economical use of your

memory, and consist of:- LET; PRINT; IF; GOSUB;

RETURN; INPUT; REM; STOP; GOTO; LIST; NEW;

RUN; SAVE; ABS; RND

**BASIC LEVEL B** As previously advertised

LEVEL A or B in 2x2708 PROMS

£21.50

LEVEL B Cassette

£ 7.50

LEVEL C in 4x2708 PROMS

£42.00

LEVEL C Cassette

£12.50

Partial disassembler/debug

£ 5.00

Superstartrek for Level B or C

£ 4.50

Relocator package

£ 4.00

All products fully documented

**C C SOFT (Southfields)**  
83 Longfield St. London SW18  
Tel: 01-870 4891 (Anytime)  
Callers by appointment please

## EQUINOX 300

A powerful multi-user  
multi-tasking  
multi-language

16-bit microcomputer time-sharing system

supporting

\* BASIC

\* LISP

\* PASCAL

\* Floppy discs

\* Hard discs

including a powerful Text Formatter,  
Assembly Language Development System  
and disc-based Sort utilities.

Priced from under £5,000

Write or phone for further information

**EQUINOX COMPUTER SYSTEMS LTD**  
16 Anning Street,  
New Inn Yard  
London E.C.2.  
(Tel: 01-739 2387/8/9)

# PARKINSON'S REVAS

Continued from Vol. 2, No. 2.

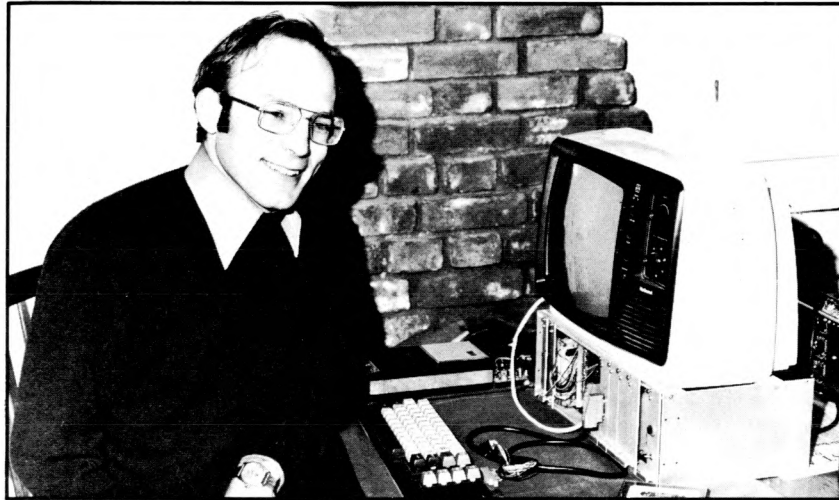

D. W. Parkinson

## A Z80 Reverse Assembler — Addendum

Murphy's Law (variation n):— No matter how many copies of a program are in use, any errors will only surface once the listing is set in type.

There is one small error in the published listing which results in RETI not being decoded. This is easily corrected by changing the first line in the RETN/RETI section from CP SA9 to CP SAA.

The REGPR routine produces a wrong set of register-pairs for the 16-bit arithmetic mnemonics when operating with IX or IY in place of HL. (eg ADD IX, BC appears as ADD IX, DE; ADD IY, BC as ADD IY, HL). This can be corrected by recording the REGPR routine as below. (The final jump is necessary to keep the change within the bounds of the old routine.)

When I wrote the original version of REVAS I did not bother to bar four invalid opcodes. They and their associated mnemonics are:—

```
ED 63 n n LD (nn), HL
ED 6B n n LD HL, (nn)
ED 70 IN (HL), (C)
ED 71 OUT (C), (HL)
```

The first two the Z80 actually executes (look at the 'ED' instruction map to see why) but I assume are not documented because of the shorter 8080 equivalent. (Also the DD/FD prefix for IX/IY does not work). The latter two don't exist and I apologise for their appearance in the published version of REVAS. They can be prevented by adding the following code at the start of the IN R, (C) and OUT (C), R sections:—

```
CP $E ($2E for OUT section)
```

```
JP Z, NOTVAL
```

Purists who want to remove the first two as well can insert:—

```
AND $E
```

```
CP $C
```

```
JP Z, NOTVAL
```

at the start of the LD PP, (\$NNNN) . . . section. (Line 848)

Another point mentioned in the text of the article, but not explained as fully as it might have been, concerns DD and FD, the index operators. These only serve to set a flag to indicate use of the appropriate index register in place of HL, and if the following opcode does not reference HL the flag is not checked. A code sequence such as FD 3E 4F is decoded as LD A,\$4F or DD C3 . . . as JP \$ . . . rather than as invalid code.

```
0293 ;
0294 ;REGISTER PAIR DECODE/PRINT
0295 ;
47 0296 REGPR: LD B,A ;SAVE IN B
0F 0297 RRCA ;SHIFT PAIR ID BITS DOWN
0F 0298 RRCA
0F 0299 RRCA
C6 02 0300 ADD 2 ;ALTER REG. CODING
0E 06 0301 LD C,6 ;PUT 6 IN C
A1 0302 AND C ;ISOLATE REG. ID
21 A1 F9 0303 LD HL,RPRTAB ;LOAD BASE ADDRESS
20 07 0304 JR NZ,NOTSP ;SKIP IF NOT 'SP'
2E 0305 DEC HL ;POINT TO "SP"
CB 78 0306 BIT 7,B ;IS IT PUSH/POP?
23 94 0307 JR Z,COPY2 ;NO DONE
2B 0308 DEC HL ;YES,POINT...
2B 0309 DEC HL ;...TO "AF"
B9 0310 NOTSP: CP C ;IS IT "HL"?
20 04 0311 JR NZ,*+4 ;NO,SKIP
3A 0B 10 0312 LD A,(HXYFLG);LOAD FLAG
81 0313 ADD C ;ADJUST IF 1X/IY
C3 B2 FA 0314 JP CCODES+7 ;SKIP TO CALL FTADR,JP COPY2
00 0315 NOP ;FILLER
```

altered code

```
F91F ED A0 0237 COPY5: LDI
F921 ED A0 0238 COPY4: LDI
F923 ED A0 0239 COPY3: LDI
F925 ED A0 0240 COPY2: LDI
F927 ED A0 0241 LDI
F929 C9 0242 RET
F92A 0243 ;
F92A 0244 ;FORM ADDRESS FOR TABLE LOOK UP
F92A 0245 ;
F92A 4F 0246 FTADR: LD C,A ;PUT OFFSET IN C
F92B 06 00 0247 LD B,0 ;CLEAR B
F92D 09 0248 ADD HL,BC ;ADD IN TO ADDRESS BASE
F92E C9 0249 RET
F92F 0250 ;
F92F 0251 ;INC/DEC REGISTER/REGISTER PAIR
F92F 0252 ;
F92F 21 47 F9 0253 INC: LD HL,INCM ;POINT TO "INC"
F932 18 03 0254 JR *+3 ;SKIP
```

(Listing continued)

F934	21 4A F9	0255	DEC:	LD	HL,DECM	:POINT TO "DEC"	F9AD	F1	0324	POP	AF	:RECOVER OP CODE	
F937	CD 23 F9	0256		CALL	COPY3	:COPY OVER	F9AD	F1	0325	LOAD8:	CP	:HALT?	
F938	13	0257		INC	DE	:SPACE	F9AE	F8 76	0326	CP	\$76	:HALT?	
F939	13	0258		INC	DE	:SPACE	F9B0	F8 60	0327	JR	Z,HALT	:YES,JUMP	
F93C	F1	0259		POP	AF	:RECOVER OP CODE	F9B2	F5	0328	PUSH	AF	:SAVE OP CODE	
F93D	CB 57	0260		POP	AF	:RECOVER OP CODE	F9B3	CD 06 F9	0329	CALL	WRLD	:WRITE "LD"	
F93E	28 3D	0261		BIT	2,A	:TEST 8/16 BIT	F9B6	0F	0330	RCRA	WRLD	:SHIFT REG ID DOWN	
F93F	28 3D	0262		JR	Z,REGPR	:JUMP IF 16 BIT	F9B7	0F	0331	RCRA	RCRA		
F941	0F	0263		RCRA		:SHIFT REG. ID....	F9B8	0F	0332	RCRA	RCRA		
F942	0F	0264		RCRA		:...DOWN TO LOW A	F9B9	CD C4 F9	0333	CALL	SREG	:PRINT IT	
F943	0F	0265		RCRA			F9BC	CD 11 F9	0334	CALL	COMMA	:GET OP CODE BACK	
F944	C3 C4 F9	0266		JP	SREG	:RETURN AFTER PRINTING REGISTER	F9BF	CB 77	0335	POP	AF	:TEST FOR IMMED. DATA	
F947	49 4E 43	0267		INC	'INC'		F9C0	F1 77	0336	BIT	6,A		
F948	44 45 43	0268		DEC	'DEC'		F9C2	28 45	0337	JR	Z,IMM	:JUMP IF SO	
F94D	44 45 43	0269		DEC	'DEC'		F9C4		0339				
F94D		0270		:16-BIT DIRECT LOAD			F9C4		0340	:SINGLE REGISTER DECODE			
F94D	CD 06 F9	0271		CALL	WRLD	:WRITE "LD"	F9C4	3C	0341	INC	A	:ADJUST CODING	
F94D	F1	0272		POP	AF	:RECOVER OP CODE	F9C4	07	0342	INC	A	:ADJUST CODING	
F950	CD 7E F9	0273		CALL	REGPR	:PRINT REGISTER PAIR	F9C7	FE 07	0343	CP	7	:ISOLATE IT	
F951	CD 11 F9	0274		CALL	COMMA	" "	F9C9	21 A2 F9	0344	JR	Z,MEM	:IS IT MEMORY?	
F954	CD DB F8	0275		CALL	BYTE	:GET LO BYTE	F9CB	28 0A F9	0345	LD	HL,RPRTAB+1,LOAD BASE ADDRESS	:YES,JUMP	
F954	4F	0276		LD	C,A	:SAVE IN C	F9CE	CD 2A F9	0346	CALL	FIADR	:FORN ADDRESS	
F958	CD DB F8	0277		CALL	BYTE	:GET HI BYTE	F9D1	ED A0	0347	CALL	LDI	:FORN ADDRESS	
F958	F7	0278		LD	H,A	:PUT IN H	F9D3	C9	0348	RET		:COPY OVER REG	
F95E	69	0279		LD	L,C	:RECOVER FIRST BYTE	F9D4	3E 28	0350	MEM:	LD	A,'('	
F95E	ED 53 10 10	0280		LD	(LABELP),DE:SAVE POINTER		F9D6	12	0351	LD	(DE),A	:WRITE "("	
F964	22 0E 10	0281		LD	(LABELA),H:SAVE ADDRESS (?)		F9D7	13	0352	INC	DE	:BUMP ADDRESS	
F967	CD 17 F9	0282		CALL	DOLLAR	"\$"	F9D8	21 A7 F9	0353	LD	HL,HXYTAB	:BUMP ADDRESS	
F96A	C3 DO F8	0283		CALL	HEXA	:RETURN,PRINTING HL.	F9DB	3A 08 10	0354	LD	A,(HXFLG)	:OFFSET IF INDEX	
F96D		0284					F9DE	CD 2A F9	0355	CALL	FIADR	:FORN ADDRESS	
F96D		0285					F9E1	CD 25 F9	0356	CALL	COPY2	:COPY OVER	
F96D		0286					F9E4	3A DO 10	0357	LD	A,(HXYFLG)	:IS IT INDEX?	
F96D		0287					F9E7	A7	0358	AND	A	:TEST	
F96D		0288					F9E8	28 1A	0359	JR	Z,NOTIXY	:NO,JUMP	
F96D	21 34 FA	0289		LD	HL,ARTAB	:POINT TO "ADD"	F9EA		0360				
F970	CD 23 F9	0290		CALL	COPY3	:WRITE IT	F9EA	CD DB F8	0361	CALL	BYTE	:YES,GET OFFSET	
F973	13	0291		INC	DE	:SPACE	F9ED	A7	0362	AND	A	:TEST IT	
F974	13	0292		INC	DE	:SPACE	F9EE	0E 2B	0363	LD	C,'+'	:SET POSITIVE	
F975	3E 20	0292		LD	A,\$20	:MAKE LIKE "HL"	F9F0	28 12 F9	0364	JR	Z,NOTIXY	:SKIP IF ZERO	
F977	CD 7E F9	0293		CALL	REGPR	:WRITE HL,IX,OR IY	F9F2	F2 F0 F9	0365	JR	F,PLUS	:JUMP IF IT WAS +VE	
F97A	CD 11 F9	0294		CALL	COMMA	" "	F9F5	ED 44	0366	NEG		:S COMP	
F97D	F1	0295		POP	AF	:RECOVER OP CODE	F9F5		0367	LD	C,'-'	:CHANGE SIGN	
F97E		0296					F9F7	0E 2D	0368	LD	B,A	:SAVE MAGNITUDE	
F97E		0297		:REGISTER PAIR DECODE/PRINT			F9F9	47	0369	LD	A,C	:GET SIGN	
F97E		0298					F9FA	79	0370	LD	(DE),A	:PRINT IT	
F97E	47	0299		REGPR:	LD	B,A	F9FB	12	0371	LD	DE	:BUMP ADDRESS	
F97E	0F	0300			RCRA		F9FC	13	0372	INC	DE	:GET MAGNITUDE	
F980	0F	0301			RCRA		F9FD	78	0373	LD	A,B	:SET MAGNITUDE	
F981	0F	0302			RCRA		F9FE	CD 17 F9	0374	CALL	DOLLAR	:PRINT MAGNITUDE	
F982	C6 02	0303		ADD	2	:ALTER REG. CODING	FA01	CD B8 F8	0375	CALL	HEX2	:PRINT MAGNITUDE	
F984	E6 06	0304		AND	6	:ISOLATE REG. ID	FA04	3E 29	0376	LD	A,'('	:CLOSE BRACKETS	
F984	21 A1 F9	0305		LD	HL,RPRTAB	:LOAD BASE ADDRESS	FA06	12	0377	LD	(DE),A		
F989	20 09	0306		JR	WZ,NOTSP	:SKIP IF NOT "SP"	FA07	13	0378	INC	DE		
F989	2B	0307		DEC	HL	:CORRECT POINTER	FA08	C9	0379	RET			
F98C	CB 78	0308		BIT	7,B	:IS IT PUSH/POP?	FA09		0380	:GET SINGLE BYTE IMMEDIATE			
F98E	2B 95	0309		JR	Z,COPY2	:NO DOME	FA09		0381	:IMM:	CALL	BYTE	:GET DATA
F990	2B	0310		DEC	HL	:YES,POINT...	FA09	CD DB F8	0382	CALL	DOLLAR	:PRINT "\$"	
F991	2B	0311		DEC	HL	:...TO 'AF'	FA0C	CD 17 F9	0383	CALL	HEX2	:PRINT DATA	
F992	18 91	0312		JR	COPY2	:COPY OVER.	FA0E	C3 B8 F8	0384	JP	HEX2		
F994	47	0313		LD	B,A	:SAVE REG.	FA12		0385				
F995	3A 0B 10	0314		LD	A,(HXYFLG)	:LOAD FLAG	FA12		0386	:HALT INSTRUCTION			
F998	80	0315		ADD	B	:OFFSET IF IX/IY	FA12	21 18 FA	0387	HALT:	LD	HL,HALTM	:EXIT VIA COPY4
F999	CD 2A F9	0316		CALL	FTADR	:ADJUST ADDRESS	FA15	C3 21 F9	0388	HALT:	JP	JP	
F99C	18 87	0317		JR	COPY2	:COPY OVER	FA18	48 41 4C 54	0389	HALTM:	HALT:	'HALT'	
F99E		0318					FA1C		0391	:R-BIT ARITHMETIC			
F9A1	44 45 53	0319					FA1C		0392	:R-BIT ARITHMETIC			
F9A1	50 41 42 43	0320		RRPTAB:	DB	'PABCD'	FA1C		0394	ARITH9:	POP	AF	:RECOVER OP CODE
F9A7	48 4C 49 58	0321		HXYTAB:	DB	'HLIXY'	FA1D	EE 40	0395	XOR	\$40	:TOGGLE BIT	
F9AD	49 59	0322		:8-BIT LOAD INSTRUCTIONS			FA1E	F5	0396	PUSH	AF	:PUT IT BACK	

FA20	OF	0397	RRCA		;GET OP ID	FA9F	52 45 54 20	0465	CJRTAB: DB	'RET JP CALL'
FA21	OF	0398	RRCA				4A 50 20 20			
FA22	E6 OE	0399	AND	\$E	;ISOLATE IT		43 41 4C 4C			
FA24	47	0400	LD	B,A	;*3 IT	FAAB		0466	;	
FA25	OF	0401	RRCA			FAAB		0467	;	DECODE CONDITION CODES
FA26	80	0402	ADD	B		FAAB		0468	;	
FA27	21 34 FA	0403	LD	HL,ARTAB	;LOAD BASE ADDRESS	FAAB	OF	0469	CCODES: RRCA	;SHIFT DOWN
FA2A	C4 2A F9	0404	CALL	NZ,FTADR	;FORM ADDRESS	FAAC	OF	0470	RRCA	
FA2D	CD 23 F9	0405	CALL	COPY3	;COPY MNEMONIC	FAAF	E6 OE	0471	AND	\$E ;ISOLATE
FA30	13	0406	INC	DE	;BUMP ADDRESS	FAAF	21 B9 FA	0472	LD	HL,CCTAB ;LOAD BASE ADDRESS
FA31	13	0407	INC	DE		FAB2	C4 2A F9	0473	CALL	NZ,FTADR ;FORM ADDRESS
FA32	18 8B	0408	JR	L8B	;PRINT OPERAND	FAB5	C3 25 F9	0474	JP	COPY2 ;RETURN VIA COPY2
FA34		0409	;			FAB8		0475	;	
FA34	41 44 44 41	0410	ARTAB: DB	'ADDADCSUBSBC'		FAB8	4E 5A 20 5A	0476	CCTAB: DB	'NZ ZNC CPOPE P M'
	44 43 53 55						4E 43 20 43			
	42 53 42 43						50 4F 50 45			
FA40	41 4E 44 58	0411	DB	'ANDXOROR CP '			20 50 20 4D			
	4F 52 4F 52					FAC8		0477	;	
	20 43 50 20					FAC8		0478	;	SINGLE BYTE ROTATE & MISC.
FA4C		0412	;			FAC8		0479	;	
FA4C		0413	;	POP		FAC8	F1	0480	ROTMIS: POP AF	;RECOVER OPCODE
FA4C		0414	;			FAC9	OF	0481	RRCA	
FA4C	21 5F FA	0415	POP: LD	HL,POPM	;LOAD POINTER	FACA	E6 1C	0482	AND	\$1C ;ISOLATE ID
FA4F	18 03	0416	JR	*+3	;SKIP	FACC	21 D5 FA	0483	LD	HL,RMTAB ;LOAD BASE ADDRESS
FA51		0417	;			FACF	C4 2A F9	0484	CALL	NZ,FTADR ;FORM ADDRESS
FA51		0418	;	PUSH		FAD2	C3 21 F9	0485	JP	COPY4 ;WRITE TO BUFFER
FA51		0419	;			FAD5		0486	;	
FA51	21 5B FA	0420	PUSH: LD	HL,PUSHM	;LOAD POINTER	FAD5	52 4C 43 41	0487	RMTAB: DB	'RLCARRCARLA RRA '
FA54	CD 21 F9	0421	PUSH1: CALL	COPY4	;PRINT MNEMONIC		52 52 43 41			
FA57	13	0422	INC	DE	;SPACE		52 4C 41 20			
FA58	C3 7D F9	0423	JP	REGPR-1	;GET OP & PR. REG PAIR		52 52 41 20			
FA5B	50 55 53 48	0424	PUSHM: DB	'PUSH'		FAE5	44 41 41 20	0488	DB	'DAA CPL SCF CCF '
FA5F	50 4F 50 20	0425	POPM: DB	'POP'			43 50 4C 20			
FA63		0426	;				53 43 46 20			
FA63		0427	;	CALL/IX/EXTENDED/IY			43 43 46 20			
FA63		0428	;			FAF5		0489	;	
FA63	F1	0429	CALETC: POP	AF	;RECOVER OPCODE	FAF5		0490	;	RESTART
FA64	FE ED	0430	CP	\$ED	;EXTENDED?	FAF5		0491	;	
FA66	CA 08 FD	0431	JP	Z,EXTND	;YES, JUMP	FAF5	21 06 FB	0492	RST: LD	HL,RSTM ;WRITE "RST"
FA69	FE CD	0432	CP	\$CD	;CALL?	FAF8	CD 23 F9	0493	CALL	COPY3
FA6B	28 OE	0433	JR	Z,CJR+1	;YES, JUMP	FAFB	13	0494	INC	DE ;SPACE
FA6D		0434	;	SET IX/IY FLAG		F AFC	13	0495	INC	DE ;SPACE
FA6D	D6 F9	0435	SUB	\$F9	;LEAVES 4 IF IY	F AFD	F1	0496	POP	AF ;RECOVER OPCODE
FA6F	30 02	0436	JR	NC,*+2	;SKIP IF 4	F AFE	E6 38	0497	AND	\$38 ;ISOLATE ADDRESS
FA71	3E 02	0437	LD	A,2	;ELSE LOAD 2	FB00	CD 17 F9	0498	CALL	DOLLAR ;WRITE "\$"
FA73	32 0B 10	0438	LD	(HXYFLG),A	;SET FLAG	FB03	C3 B8 F8	0499	JP	HEX2 ;PRINT RST ADDRESS
FA76	F1	0439	POP	AF	;THROW AWAY RETURN	FB06		0500	;	
FA77	C3 19 F8	0440	JP	MORE	;GO FOR MORE	FB06	52 53 54	0501	RSTM: DB	'RST'
FA7A		0441	;			FB09		0502	;	
FA7A		0442	;	CALL/JUMP/RETURN		FB09		0503	;	WRITE "NOP"
FA7A		0443	;			FB09		0504	;	
FA7A	F1	0444	CJR: POP	AF	;RECOVER OPCODE	FB09	21 0F FB	0505	NOP: LD	HL,NOPM
FA7B	F5	0445	PUSH	AF	;SAVE IT	FB0C	C3 23 F9	0506	JP	COPY3
FA7C	E6 06	0446	AND	6	;ISOLATE ID	FB0F	4E 4F 50	0507	NOPM: DB	'NOP'
FA7E	07	0447	RLCA			FB12		0508	;	
FA7F	21 9F FA	0448	LD	HL,CJRTAB	;LOAD BASE ADDRESS	FB12		0509	;	DJNZ
FA82	C4 2A F9	0449	CALL	NZ,FTADR	;FORM ADDRESS	FB12		0510	;	
FA85	CD 21 F9	0450	CALL	COPY4	;WRITE MNEMONIC	FB12	21 1B FB	0511	DJNZ: LD	HL,DJNZM ;WRITE "DJNZ"
FA88	13	0451	INC	DE	;SPACE	FB15	CD 21 F9	0512	CALL	COPY4
FA89	F1	0452	POP	AF	;GET OPCODE BACK	FB18	13	0513	INC	DE ;SPACE
FA8A	FE C9	0453	CP	\$C9	;UNCOND RETURN?	FB19	18 20	0514	JR	UCD ;REST IN "JR" ROUTINE
FA8C	C8	0454	RET	Z	;YES, RETURN	FB1B	44 4A 4E 5A	0515	DJNZM: DB	'DJNZ'
FA8D	CB 47	0455	BIT	0,A	;UNCOND. CALL/JUMP?	FB1F		0516	;	
FA8F	20 0B	0456	JR	NZ,UNCND	;YES, SKIP	FB1F		0517	;	NOP/DJNZ/JR NZ/JR NC
FA91	F5	0457	PUSH	AF	;SAVE AGAIN	FB1F		0518	;	
FA92	CD AB FA	0458	CALL	CCODES	;ADD CONDITION	FB1F	F1	0519	NOPETC: POP	AF ;RECOVER OPCODE
FA95	F1	0459	POP	AF	;RECOVER AGAIN	FB20	FE 10	0520	CP	\$10 ;DJNZ?
FA96	E6 07	0460	AND	7	;CHECK FOR RETURN?	FB22	28 EE	0521	JR	Z,DJNZ ;YES, JUMP
FA98	C8	0461	RET	Z	;YES, RETURN					
FA99	CD 11 F9	0462	CALL	COMMA	;					
FA9C	C3 57 F9	0463	UNCND: JP	LD16A	;EXIT WRITING "\$NNNN"					
FA9F		0464	;							

To Be Continued

# HORIZON



## For Business, Scientific and Educational Uses.

### PROFESSIONAL HARDWARE

Use of the North Star Horizon for a short period will enable you to appreciate the professionalism in the product. There's a solid well-built chassis, a good power supply, a quiet fan and an attractive wooden case. There's a Z80A processor running at 4MHz with the 250ns static RAM boards.

There are dual integral Shugart minifloppy drives (capacity of about 360 KB on line, with an option for a further two drives), enabling easy and quick handling and copying of programs and data files.

And of course, there's the 12 slot S-100 bus which enables you to plug in many types of peripheral boards, including a hardware floating point board for increased "number crunching" performance.

### PROFESSIONAL SOFTWARE

North Star Computers built their professional reputation around their powerful, but simple, Disc Operating System and Disc Extended BASIC Interpreter.

The latter contains, in addition to the usual BASIC commands, random and sequential access disc files, strings, string operators, multiple dimensioned arrays, formatted output, machine language CALL, memory EXAMine and FILL, line editor, program chaining and more.

The CP/M operating system is also available as an option and provides access to a Macro Assembler, C BASIC Compiler and FORTRAN-80 and COBOL-80 Compilers. A standard UCSD PASCAL has now been implemented.

### TYPICAL APPLICATIONS SOFTWARE

- Financial
- Mathematical
- Statistical
- Educational
- Games
- Sales Ledger
- Purchase Ledger
- Stock Control
- Payroll
- General Ledger
- Estate Agents Package
- Incomplete Records
- Employment Agents

HORIZON with dual drives, 24K RAM and standard serial port — £1823. Extra 8K 250ns static memory — £155. Extra serial port — £45. Parallel port — £45.

**COMPLETE HORIZON BUSINESS SYSTEM** (hardware) with 24K RAM, dual mini-floppy drives, VDU and 30cps printer — £3616; 32K RAM, dual mini-floppy drives, VDU and 150cps printer £4658.

Prices exclude VAT and carriage.

Dealer, OEM and Educational Discounts available.

## EQUINOX

COMPUTER SYSTEMS LTD.

"KLEEMAN HOUSE"

16 ANNING STREET, NEW INN YARD,  
LONDON EC2A 3HB.

Tel: 01-739 2387/9 01-729 4460

# JUST COMPARE OUR CASH AND CARRY PRICES!

## PET COSTS LESS AT COMP and it's a pedigree

RRP £550

The No. 1 Personal Computer in the U.K. Affordable for the first time user and the professional check out the PET, the world's most popular personal computer.



EX STOCK

8K — £499    16K — £590  
32K with GREEN SCREEN — £690    Cassette recorder now in stock £55

## ADD A PRINTER TO YOUR PET

RS232C I/O CARD

Attach to any RS232 printer, modem, acoustic coupler to your PET. Easy to assemble. £89 in kit form. Add £20 for fully assembled and tested.

## PET TO \$100 FOR MEMORY EXPANSION

Convert the IEEE 488 bus to the well supported \$100 bus. Comes complete. Connectors and documentation included. Ready assembled and tested. Our price £89.

## SOUND BOXES FOR PET

Fully assembled with documentation how to add sound effects to your programs. £14.90

## BEST GAME EVER!

Petball — £5 for program  
This game will have you and your family in tears for hours! For full effect buy sound box too! Best seller in U.S.A.

## NASCOM IMMEDIATE EXPANSION \$100 from COMP —strongly recommended

The only available \$100 motherboard kit (fully buffered) that plugs directly into your Nascom. Designed for the insertion of \$100 boards (e.g. Static RAM, EPROM and discs etc.).

S100 Motherboard/Buffer (Complete kit + documentation)	£47.50	} Buy both and get 2K Tiny Basic On cassette FREE.
Suitable 8K Static RAM Memory (fully assembled tested and guaranteed)	£125	

## MODULATORS UHF Channel 36

Standard 6 meg band width £2.25  
High Quality 8 meg band width £4.90 EX-STOCK

## UNIVERSAL POWER SUPPLY

Suitable for Nascom I, Nascom II, Superboard and all computers requiring these specifications.  
+5V @ 3 amps    +12V @ 1 amp    -5V @ 500 mills    -12V @ 500 mills  
Easy to construct — complete with transformer. Our price £24.90

## TRANSFORMER

Primary 220V with 2 individual secondaries £5.90  
8V —0 —8V @ 1½ amps    16V —0 —16V @ ½ amp

## HITACHI PRO MONITORS

Superb definition 9" — £132    12" — £210

## THE TRS-80 (SPECIAL SCOOP) Low Priced, Ready to Go!

PLUGS INTO YOUR OWN TV

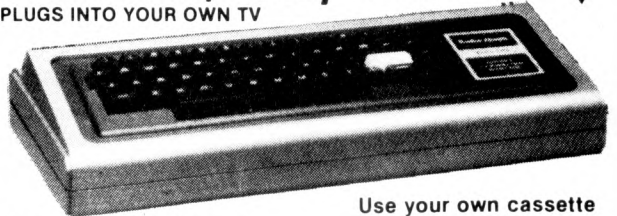

Use your own cassette

### Level-II with 4K RAM

Improved graphics, print formatting, and a faster cassette transfer rate are features of Level-II Basic. £350 + VAT

### Level-II with 16K RAM

A combination of 16K RAM and the powerful Level-1! BASIC produces a system capable of handling most demands. £399 + VAT

64 chars x 16 lines — double length characters available at a single keystroke giving 32 chars x 16 lines. Super graphics a 2 x 3 cell arrangement. Masses of software available.

World's most popular machine. Fully converted to English Television standard. Rock steady picture — exclusive to COMP.

UK POWER SUPPLY SUPPLIED

KEY BOARD ONLY — Complete with UHF Modulator

## RS232C I/O CARD for TRS80

Connect your TRS80 to any RS232 printer. Assembled and tested £55

## SOUND BOXES FOR TRS80

Fully assembled with documentation how to add sound effects to your programs. £14.90

## ATTENTION ALL NERVOUS TRS80's

Cure the video shakes. Upgrade your video to English Standard. Simple modification. Only £7.50 including easy to follow instructions. Only 15 minutes of your time needed. You owe it to your eyesight. Fitted as standard to all our machines.

## NEW! AT LAST 8K BASIC FOR NASCOM 1

COMPLETE ON S100 EPROM BOARD £160 + VAT EX-STOCK

## BEST GAME EVER!

Android Nim — for TRS80. £5 for program  
This game will have you and your family in tears for hours!  
For full effect buy sound box too! Best seller in U.S.A.

## TRS80 TO \$100 BUS

for memory expansion £95

## TV UHF MODULATOR FOR TRS80

Encased ready to use — £15

## ELECTRIC PENCIL

Text Wordprocessing package on cassette £59

Please add VAT to all prices — Delivery at cost, will be advised at time of purchase. Please make cheques and postal orders payable to COMP, or phone your order quoting BARCLAYCARD, ACCESS, DINERS CLUB or AMERICAN EXPRESS number.

OPEN — 10am to 7pm — Monday to Saturday  
CREDIT FACILITIES ARRANGED



EUROPE'S FASTEST SELLING ONE BOARD COMPUTER — JUST CHECK THE SPEC'S.

# COMPUKIT UK101

## LOW COST SUPERBOARD IN KIT FORM



The CompuKit UK101 has everything a one board 'superboard' should have.

- ★ Uses ultra-powerful 6502 microprocessor.
- ★ 50Hz Frame refresh for steady clear picture (U.S.A. products with 60Hz frame refresh always results in jittery displays)
- ★ 48 chars by 16 lines — 1K memory mapped video system providing high speed access to screen display enabling animated games and graphs.
- ★ Extensive 256 character set which includes full upper and lower case alphanumerics, Greek symbols for mathematical constants and numerous graphic characters enabling you to form almost any shape you desire anywhere on the screen.
- ★ 8K full Microsoft Basic in ROM compatible with PET, APPLE SORCERER hence taking the headache out of programming by using simple English statements. Much faster than currently available personal computers.
- ★ Professional 52 Key keyboard in 3 colours — software polled meaning that all debouncing and key decoding done in software.

FULL CONSTRUCTION DETAILS IN P.E. AUG 1979 EDITION

Delivery date June 1979 at the 1979 MicroComputer Show Customer orders in strict rotation only.

COMMANDS	NEW	NULL	RUN
CONT LIST			
STATEMENTS			
CLEAR DATA	DEF	DIM	END FOR
GOTO GOSUB	IF, GOTO	IF, THEN	INPUT LET
NEXT ON, GOTO	ON, GOSUB	POKE	PRINT READ
REM RESTORE	RETURN	STOP	

**EXPRESSIONS**  
**OPERATORS**  
 +, \*, /, ↑ NOT, AND, OR, >, <, <>, >=, <= RANGE 10<sup>-32</sup> to 10<sup>+32</sup>

**VARIABLES**  
 A, B, C, ..., Z and two letter variables  
 The above can all be subscripted when used in an array. String variables use above names plus \$, e.g. A\$(1)

FUNCTIONS	ATN(X)	COS(X)	EXP(X)	FRE(X)	INT(X)
ABS(X)	PEEK(I)	POS(I)	RND(X)	SGN(X)	SIN(X)
LOG(X)	SQR(X)	TAB(I)	TAN(X)	USR(I)	
STRING FUNCTIONS					
ASC(X\$)	CHR\$(X)	FRE\$(X\$)	LEFT\$(X\$, I)	LEN(X\$)	MID\$(X\$, I, J)
RIGHT\$(X\$, I)		STR\$(X)		VAL(X\$)	

- ★ Video output and UHF Highgrade modulator (8MHz Bandwidth) which connects direct to the aerial socket of your T.V. Channel 36 UHF.
- ★ Fully stabilised 5V power supply including transformer on board.
- ★ Standard KANSAS city tape interface providing high reliability program storage — use on any standard domestic tape or cassette recorder.
- ★ 4K user RAM expandable to 8K on board £49 extra.
- ★ 40 line expansion interface socket on board for attachment of extender card containing 24K RAM and disk controller. (Ohio Scientific compatible).
- ★ 6502 machine code accessible through powerful 2K machine code monitor on board.
- ★ High quality thru plated P.C.B. with all I.C.'s mounted on sockets.

A tape of 10 programs on cassette — educational games, etc. will be supplied free of charge with each kit.

Simple Soldering due to clear and concise instructions compiled by Dr. A.A. Berk, BSc.PhD

NO EXTRAS NEEDED JUST HIT 'RETURN' AND GO.

Build, understand, and program your own computer for only a small outlay.

ONLY £219 + VAT including RF Modulator & Power supply. Absolutely no extras.

Due to the new prices of TTL this price will be increased shortly. So order now to beat the price increases and the rush.

### SPECIAL CHARACTERS

- @ Erases line being typed, then provides carriage return, line feed.
- ␣ Erases last character typed.
- CR Carriage Return — must be at the end of each line.
- Separates statements on a line.
- CONTROL/C Execution or printing of a list is interrupted at the end of a line.
- "BREAK IN LINE XXXX" is printed, indicating line number of next statement to be executed or printed.
- CONTROL/O No outputs occur until return made to command mode. If an input statement is encountered, either another CONTROL/O is typed, or an error occurs.
- ? Equivalent to PRINT

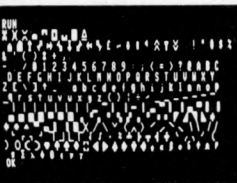
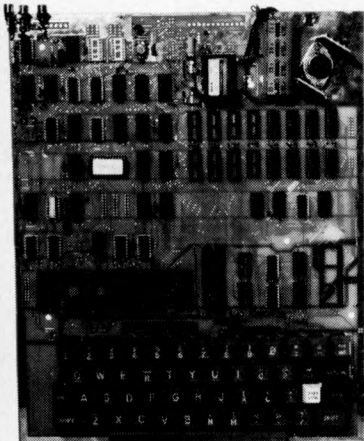

The CompuKit UK101 Character Set

## THE EXIDY SORCERER. SAVE

### SORCERER COMPUTER SYSTEM

The Sorcerer Computer is a completely assembled and tested computer system. Standard configuration includes 63-key typewriter style keyboard and 16-key numeric pad, 280 processor, dual cassette I/O with remote computer control at 300 and 1200 baud data rates, RS232 serial I/O for communications, parallel port for direct Centronics printer attachment, 4K ROM operating system, 8K ROM Microsoft BASIC in Rom Pac™ cartridge, composite video of 64 char/line 30 line/screen, 128 upper/lower case ASCII set and 128 user-defined graphic symbols, operation manual, BASIC programming manual and cassette/video cables, connection for S-100 bus expansion.



CPM NOW



LOOK!

- \*32K RAM on board
- \*RS232 interface
- \*4K BASIC ROM
- \*CUTS interface
- \*4K MONITOR
- \*KANSAS CITY interface
- \*S100 BUS
- \*User defined graphic symbols
- \*280 cpu

16K £860 £725 \* 32K £950 £790 \* Credit facilities available. \* + VAT

## IBM GOLF BALL SELECTIVE PRINTER

Refurbished to new specifications. RS232C serial interface. Comes complete on stand — floor mounting. Small and compact. Interfaces to Exidy Sorcerer, TRS80 Apple and ITT 2020, Pet, CompuKit and Nascom. Complete your word processing system with a top quality printer for only £990.50.

## THE ATARI video computer system



Atari's Video Computer System now offers more than 1300 different game variations and options in twenty great Game Program™ cartridges!

Have fun while you sharpen your mental and physical coordination. You can play rousing, challenging, sophisticated video games, the games that made Atari famous.

You'll have thrill after thrill, whether you're in the thick of a dogfight, screeching around a racetrack, or dodging asteroids in an alien galaxy. With crisp bright color (on color TV) and incredible, true-to-life sound effects. With special circuits to protect your TV.

**Cartridges now available**  
 Basic Maths, Airsea Battle, Black Jack, Breakout, Surround, Spacewar, Video Olympics, Outlaw, Basketball, All at £13.90 each.

Years and years of fun and satisfaction are assured

SAVE £30

£169 ~~£169~~ £138.85

All prices exclude VAT. Our VAT rate is 8%. We will pay any extra. Please quote this number P W1000 when ordering

## COMP COMPUTER COMPONENTS

14 STATION ROAD, NEW BARNET, HERTFORDSHIRE TEL: 01-441 2922 (Sales)  
 CLOSE TO NEW BARNET BR STATION — MOORGATE LINE 01-449 6596  
 OPEN — 10am to 7pm — Monday to Saturday TELEX: 298755



VISIT OUR NEW SHOP AT 1 WALLCOT BUILDINGS, LONDON ROAD, BATH, AVON. All Products Ex-Stock Please check availability (Part of the Compshop Ltd. Group).

# The World's Most Powerful 8-bit Microcomputer

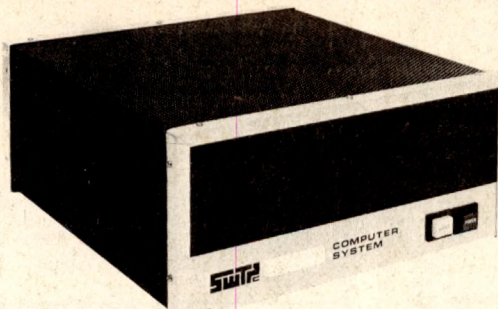

Featuring the world's most powerful MPU —  
the Motorola MC-6809

Two types of central processor are available for use in your system. The standard /09 has a maximum random access memory (RAM) capacity of fifty six thousand (56K) bytes. It can have as many as eight input/output (I/O) devices such as terminals, printers, etc, attached. This capacity is adequate for business systems requiring up to four terminals and two printers. If the application involves moving large amounts of data, or scientific and engineering calculations, our larger CPU should be used.

The S/09 CPU has a maximum RAM memory capacity of 384K bytes. It is normally supplied with 128K bytes of memory which can be expanded to 256K, or 384K by adding additional memory arrays. This CPU will support up to 16 I/O devices.

Both CPU's are designed around the Motorola MC6809 microprocessor. This is the most powerful eight-bit microprocessor available.

The MC6809 has more addressing modes than any other 8-bit processor. It has powerful 16-bit instruct-

ions, and a highly efficient internal architecture with 16-bit data paths. It is easily the most powerful, most software efficient, and the fastest 8-bit general purpose microprocessor ever.

The greatest impact of the Motorola MC6809 undoubtedly will be software related. Ten powerful addressing modes with 24 indexing submodes, 16-bit instructions and the consistent instruction set stimulate the use of modern programming techniques, such as structured programming, position independent code, re-entrancy, recursion and multitasking.

C/09 CPU	£1050 + VAT
CS/09 128K	£2100 + VAT
/09 board (will directly replace existing SWTPC processor board)	£ 195 + VAT

## CT-82 Terminal



- ★ Software function controls
- ★ 56-key "Cherry" keyboard
- ★ 12 key numeric or cursor control pad
- ★ 128 control functions
- ★ Graphics capability
- ★ User programmable character sets
- ★ Software selectable Baud rates (50-38, 400)

£550 + VAT

Write or telephone for latest brochure including 16MB disc and new printer range.

# SWTPC

**Southwest Technical Products Co.**

# CW

**Computer Workshop**

38 DOVER STREET · LONDON · W1X 3RB · Telephone: 01-491 7507 · Telex: 268913